

CURRENT TRANSFORMER

Model 170

Window Diameter 4.25"

Application:
Metering

Frequency:
50 - 400 Hz

Insulation Level:
600 Volts, 10 kv BIL full wave



E228202

- Terminals are brass studs No. 8 - 32 with one flat washer, lockwasher and regular nut.
- Flexible leads are UL 1015 105° C CSA approved, #16 AWG, 24" long
- Non-standard lead length can be specified
- Order mounting bracket kit F separately
- Model 170SHT also available as 170SHL with leads
- Approximate weight: 3 lbs.

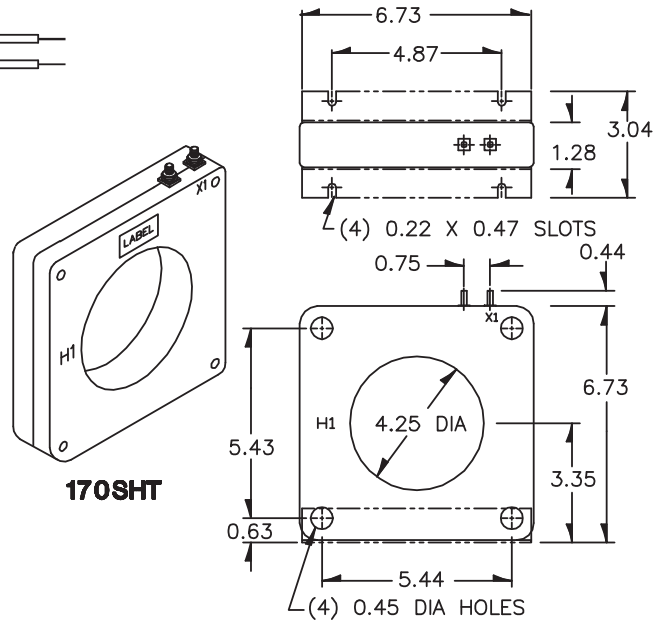
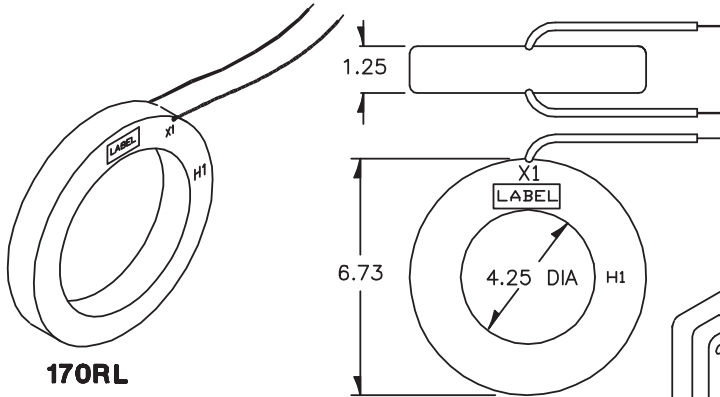

EXCITATION CURVE

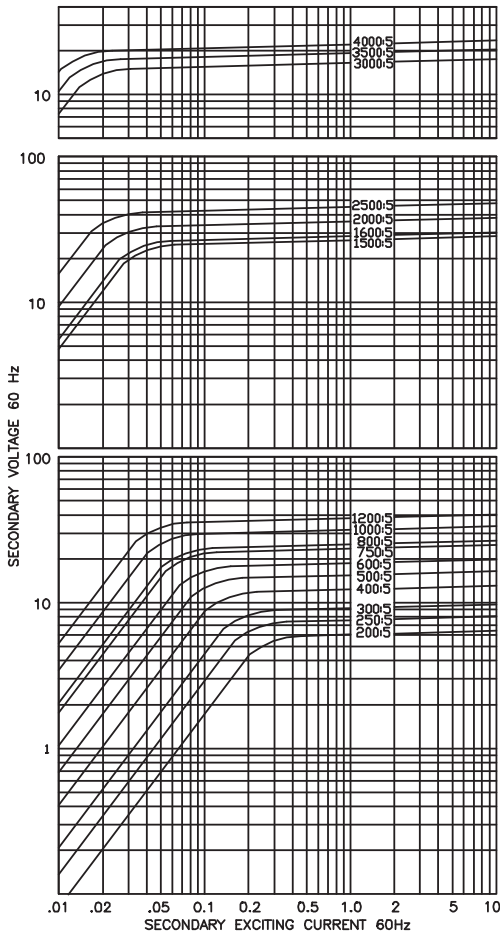

CATALOG NUMBER	CURRENT RATIO	V.A. FOR ± 1% CLASS	ANSI METERING CLASS AT 60 Hz					SECONDARY WINDING RESISTANCE (OHMS @ 75 °C)	CONTINUOUS THERMAL RATING FACTOR	
			B0.1	B0.2	B0.5	B0.9	B1.8		@30°C	@55°C
170 ** 201	200:5	5.0	0.6	1.2	2.4	—	—	0.040	2.0	2.0
170 ** 251	250:5	5.0	0.6	0.6	1.2	2.4	—	0.047	2.0	2.0
170 ** 301	300:5	12.5	0.6	0.6	1.2	2.4	—	0.053	2.0	2.0
170 ** 401	400:5	25.0	0.3	0.3	0.6	1.2	2.4	0.080	2.0	2.0
170 ** 501	500:5	25.0	0.3	0.3	0.6	1.2	1.2	0.110	2.0	1.5
170 ** 601	600:5	25.0	0.3	0.3	0.6	0.6	1.2	0.121	2.0	1.5
170 ** 751	750:5	40.0	0.3	0.3	0.3	0.3	0.6	0.151	2.0	1.5
170 ** 801	800:5	50.0	0.3	0.3	0.3	0.3	0.6	0.162	2.0	1.5
170 ** 102	1000:5	75.0	0.3	0.3	0.3	0.3	0.6	0.265	1.33	1.0
170 ** 122	1200:5	100.0	0.3	0.3	0.3	0.3	0.6	0.318	1.33	1.0
170 ** 152	1500:5	80.0	0.3	0.3	0.3	0.3	0.6	0.344	1.33	1.0
170 ** 162	1600:5	90.0	0.3	0.3	0.3	0.3	0.6	0.367	1.33	1.0
170 ** 202	2000:5	100.0	0.3	0.3	0.3	0.3	0.3	0.459	1.0	0.8
170 ** 252	2500:5	130.0	0.3	0.3	0.3	0.3	0.3	0.573	1.0	0.8
170 ** 302	3000:5	160.0	0.3	0.3	0.3	0.3	0.3	0.424	1.0	1.0
170 ** 352	3500:5	190.0	0.3	0.3	0.3	0.3	0.3	0.495	1.0	0.8
170 ** 402	4000:5	200.0	0.3	0.3	0.3	0.3	0.3	0.646	1.0	0.8

**NOTE: When ordering, prefix catalog number with model designation required, i.e. 170SHT-201, or 170RL-301.