

CURRENT TRANSFORMER

Model 6

Window Diameter 2.06"

Application:

With ammeters, wattmeters and cross current compensation.

Frequency:

50 - 400 Hz

Insulation Level:

0.6 kV, 10 kv BIL full wave



E228202

- Flexible leads are UL 1015 105°C,
 - CSA approved #16 AWG, 24" long
- Non-standard length to be specified.
- Terminals are brass studs No. 8 - 32 UNC
 - with one flat washer, lockwasher and regular nut.
- SFT and SHT case styles also available as SFL
 - and SHL with leads.
- Mounting bracket kit H when required for
 - Model 6SHT.
- Approximate weight: 1.2 lb.

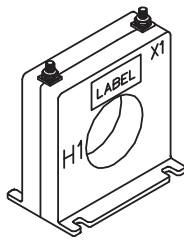

6SFT

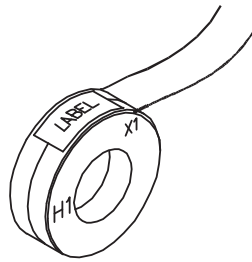

6RL

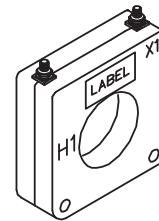

6SHT

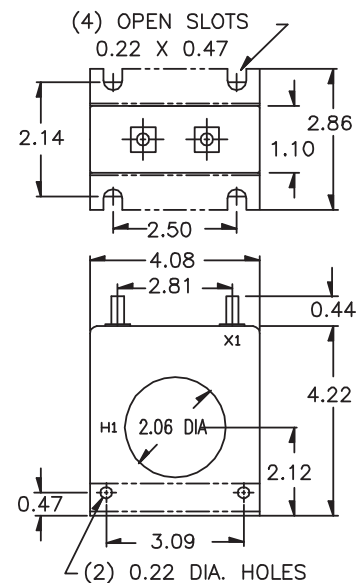
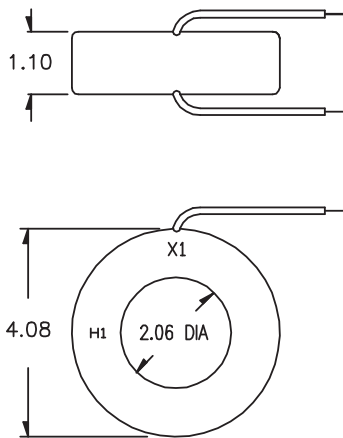
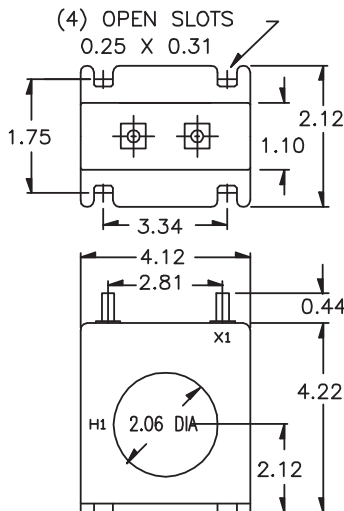

CATALOG NUMBER	CURRENT RATIO	ACCURACY AT 60 Hz	BURDEN VA at 60 Hz
6 **-101	100:5	± 2 %	2.0
6 **-151	150:5	± 1 %	5.0
6 **-201	200:5	± 1 %	5.0
6 **-251	250:5	± 1 %	7.5
6 **-301	300:5	± 1 %	12.5
6 **-401	400:5	± 1 %	15.0
6 **-501	500:5	± 1 %	25.0
6 **-601	600:5	± 1 %	30.0
6 **-751	750:5	± 1 %	25.0
6 **-801	800:5	± 1 %	25.0
6 **-102	1000:5	± 1 %	35.0
6 **-122	1200:5	± 1 %	40.0
6 **-152	1500:5	± 1 %	50.0

** NOTE: When ordering, prefix Cat No. with model designation required, i.e. 6SHT-201, 6RL-301, etc.