

INDOOR VOLTAGE TRANSFORMERS

Models PTG5-1-110 & PTG5-2-110

Frequency: 60 Hz
 Maximum System Voltage: 15.5kV, BIL 110kV

Accuracy Class: 0.3 WXYZ, 1.2ZZ at 100% rated voltage with 120V based ANSI burden. 0.3 WXY, 1.2 Z at 58% rated voltage with 69.3 V based ANSI burden

Thermal Rating: 1500VA at 30°C ambient
 1000VA at 55°C ambient

Weight: Approx. 85 lbs., unfused



- Primary terminals that are unfused are 1/4-20 brass screws with one flatwasher and lockwasher.
- Primary terminals that are fused are 1/4-20 brass screws with one flatwasher and lockwasher and two nuts.
- Secondary terminals are No. 10-32 brass screws with one flatwasher and lockwasher.

- The core and coil assembly is vacuum encapsulated in polyurethane resin.
- Thermal burden rating is for 120 volt secondaries.
- Plated steel mounting base.
- Fuses have 1.63" Dia Caps and 11.5" clip centers
- Switchgear style is similar to fused style. No fuse or fuse

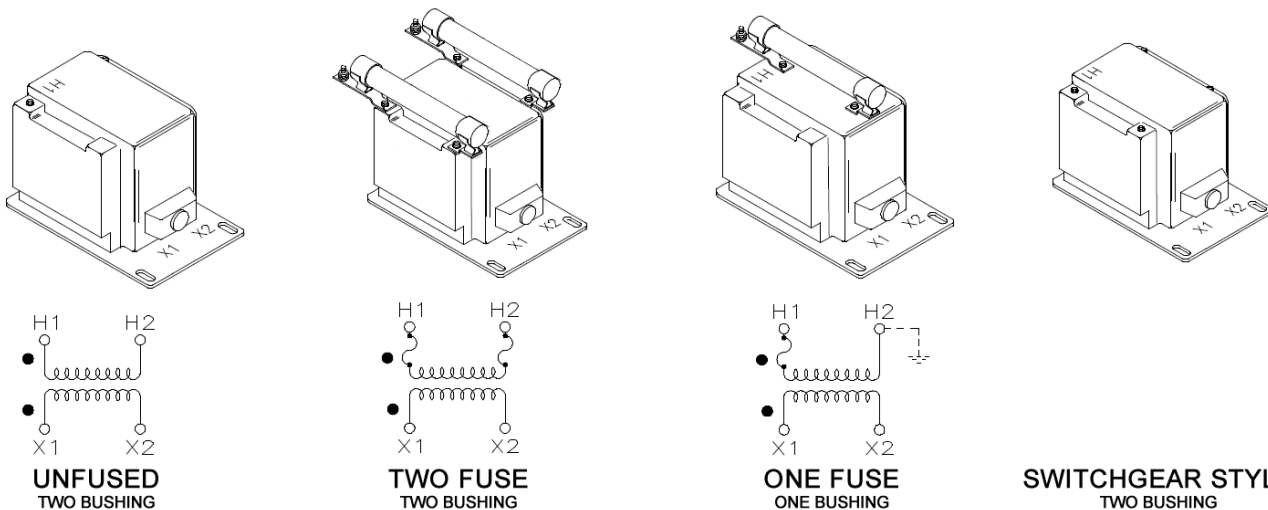

TWO BUSHING (a)				CATALOG NUMBERS			
GROUP	PRIMARY VOLTAGE	RATIO	SECONDARY VOLTAGE	UNFUSED	FUSES	FUSE CLIPS ONLY	SWITCHGEAR STYLE
1	7200	60:1	120	PTG5-2-110-722	PTG5-2-110-722FF	PTG5-2-110-722CC	PTG5-2-110-722SS
1	8400	70:1	120	PTG5-2-110-842	PTG5-2-110-842FF	PTG5-2-110-842CC	PTG5-2-110-842SS
2	11000	100:1	110-50Hz	PTG5-2-110-113	PTG5-2-110-113FF	PTG5-2-110-113CC	PTG5-2-110-113SS
2	12000	100:1	120	PTG5-2-110-123	PTG5-2-110-123FF	PTG5-2-110-123CC	PTG5-2-110-123SS
2	13200	110:1	120	PTG5-2-110-1322	PTG5-2-110-1322FF	PTG5-2-110-1322CC	PTG5-2-110-1322SS
2	13800	115:1	120	PTG5-2-110-1382	PTG5-2-110-1382FF	PTG5-2-110-1382CC	PTG5-2-110-1382SS
2	14400	120:1	120	PTG5-2-110-1442	PTG5-2-110-1442FF	PTG5-2-110-1442CC	PTG5-2-110-1442SS

ONE BUSHING (b)				CATALOG NUMBERS			
GROUP	PRIMARY VOLTAGE	RATIO	SECONDARY VOLTAGE	R FR (c)	FUSES	FUSE CLIPS ONLY	SWITCHGEAR STYLE
4A	7200	60:1	120	65	PTG5-1-110-722F	PTG5-1-110-722C	PTG5-1-110-722S
4A	8400	70:1	120	65	PTG5-1-110-842F	PTG5-1-110-842C	PTG5-1-110-842S
4B	11000	100:1	110-50Hz	65	PTG5-1-110-113F	PTG5-1-110-113C	PTG5-1-110-113S
4B	12000	100:1	120	65	PTG5-1-110-123F	PTG5-1-110-123C	PTG5-1-110-123S
4B	13200	110:1	120	65	PTG5-1-110-1322F	PTG5-1-110-1322C	PTG5-1-110-1322S
4B	13800	115:1	120	65	PTG5-1-110-1382F	PTG5-1-110-1382C	PTG5-1-110-1382S
4B	14400	120:1	120	65	PTG5-1-110-1442F	PTG5-1-110-1442C	PTG5-1-110-1442S

(a) Two fuse transformers should not be used for Y connections. It is preferred practice to connect one lead from each voltage transformer directly to the neutral terminal, using a fuse in the line side of the primary only. By using this connection a transformer can never be made live from the line side by reason of a blown fuse in the neutral side. For continuous operation the transformer primary voltage should not exceed 110% of rated value.

(b) Voltage transformers connected line-to-ground cannot be considered to be grounding transformers and must not be operated with the secondaries in closed delta because excessive currents may flow in the delta.

(c) Ferreresonance considerations. Values in table are in ohms.

Note: It is recommended that system line-to-line voltage not exceed the transformer maximum system voltage level.

PTG5-1-110 and PTG5-2-110

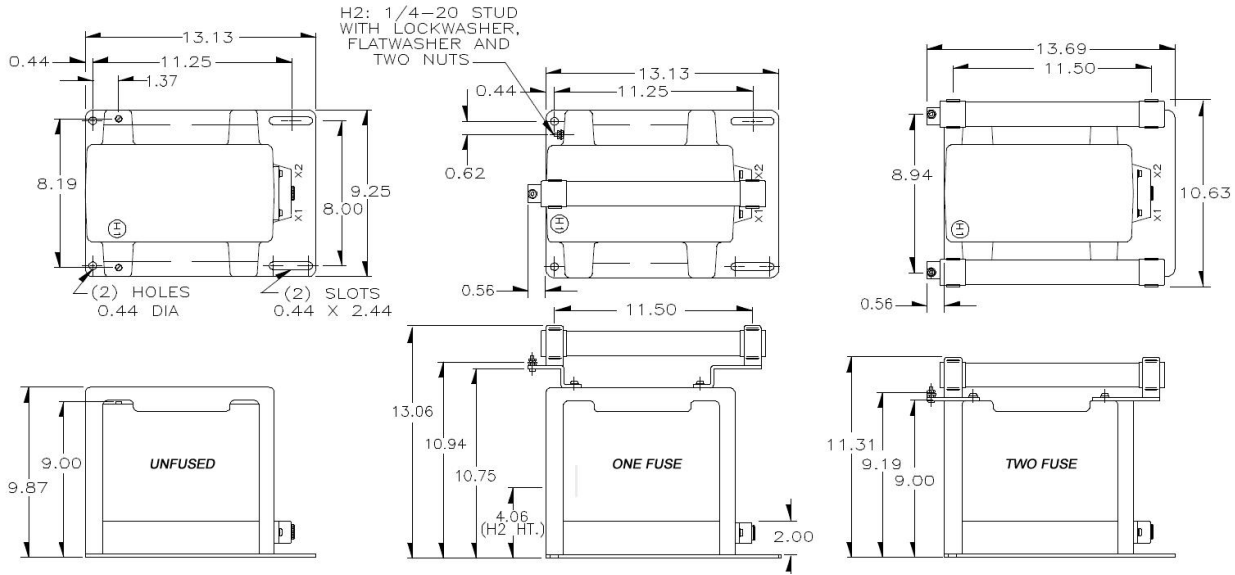

RECOMMENDED MINIMUM SPACINGS

A = Unit to Unit or to Ground = 1.25. minimum.

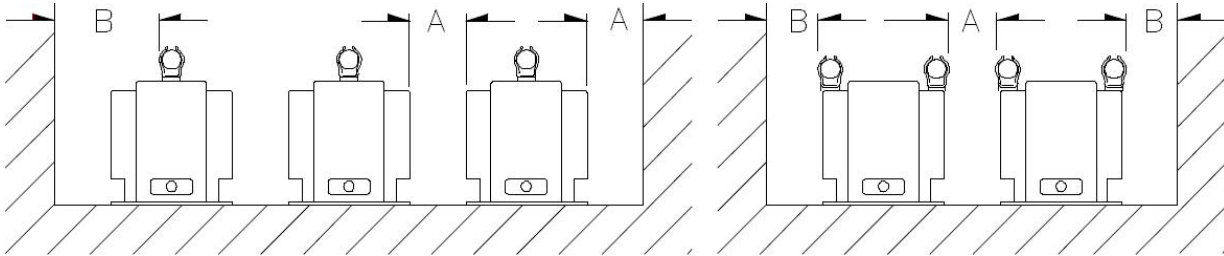

Recommended spacing are for guidance only. User needs to set appropriate values to assure performance for high potential test, impulse test, high humidity, partial discharge, high altitude, and other considerations like configuration.

FUSE FOR MODEL PTG5 TRANSFORMER	RATING VOLTS	INTERRUPTING AMPERES (SYM)	SUGGESTED RATING CONTINUOUS AMPERES	CAP DIA. INCHES	LENGTH INCHES	CLIP CENTERS INCHES
7200:120V	15.5kV	80,000	1.0E	1.63	13	11.50
8400:120V	15.5kV	80,000	1.0E	1.63	13	11.50
11000:120V	15.5kV	80,000	0.5E	1.63	13	11.50
12000:120V	15.5kV	80,000	0.5E	1.63	13	11.50
13000:120V	15.5kV	80,000	0.5E	1.63	13	11.50
15000:120V	15.5kV	80,000	0.5E	1.63	13	11.50

Circle Diagram

The circle diagram can be used to predict the performance of a transformer for various loads and power factors. A convenient scale of volt-ampere is shown on the unity power factor line (u.p.f) and commences at the zero or no-load locus. To use the diagram, measure the known V.A. and scribe an arc about the "Zero" locus of a length that contains the angle of the burden power factor. The point at which the arc terminates is the error locus in phase angle minutes and ratio correction factor.

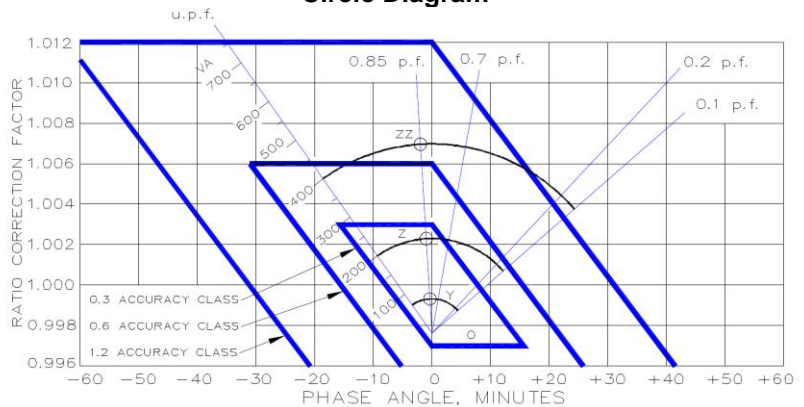

Contact us for additional information

REV MT-PTG5-032710