



MOTORTRONICS™
Solid State AC Motor Controls

VCM INVERTER SERIES

Installation & Operations Manual



230V 1Ø 0.5 - 3HP
0.4 - 2.2kW

230V 3Ø 0.5 - 40HP
0.4 - 30kW

460V 3Ø 1 - 75HP
0.75 - 55kW

Table of Contents

1.0 Introduction	1
2.0 Product Inspection	2
2.1 Nameplate Layout	2
3.0 Operating Precautions	3
3.1 Before Power up	3
3.2 During Power up	4
3.3 Before Operation	4
3.4 During Operation	5
4.0 Environment and Installation	6
4.1 Inverter Mounting	6
Fig.4.1.1 Panel and Enclosure Placement	6
Fig 4.1.2 Din Rail Mounting Clearances	7
5.0 General Wiring Diagram (1 - 2 HP and 3 – 75 HP prior to Version 1.2)	8
6.0 General Wiring Diagram (3 - 75 HP, Version 1.2 or later)	9
7.0 Power Terminals Designations and Ratings (Terminal Block TM1)	10
7.1 Power Terminal Configuration TM1	10
7.2 Power Terminal Block TM1 Electrical Ratings and Tightening Torques	11
8.0 Inverter Wiring	11
8.1 Input / Output Power Wiring Connections (Terminal TM1)	11
8.2 Input / Output Power Wiring Noise Suppression	11
Fig. 8.2 Input / Output Power Wiring Noise Suppression	11
8.3 Motor Cable Length	12
8.4 Cable Length vs Carrier Frequency	12
8.5 Inverter Grounding	12
8.6 Input Power Wiring and Installation Recommendations with Examples	13
Fig. 8.6 Input Power Wiring and Installation Examples	13
9.0 Input / Output Power Section Block Diagram	14
Fig. 9.0 Power Input / Output Block Diagrams	14
10.0 Control Terminals (Terminal Block TM2)	15
10.1 Control Terminal Designations (Terminal Block TM2)	15
10.2 Control Terminal Layout and Control Switches	16
Fig. 10.2.1 Control Terminal TM2 Layout (Prior to Version 1.3)	16
Fig. 10.2.2 Control Terminal TM2 Layout (Version 1.3 or later)	16
10.3 Control Terminal Wiring and Connections (Terminal TM2)	16
11.0 Peripheral Power Devices	17
12.0 Input Fuse Types and Ratings	18 - 19
13.0 Applicable specifications for circuit breakers and magnetic contactors	19
14.0 Reactor Input / Output Specifications	20
15.0 Braking Resistor Selections	21
16.0 EMC Filters	22
17.0 Keypad Key Functions and Navigation	23
17.1 VCM Keypad	23
17.2 Keypad LED Functions	23
17.3 Key Functions	24
17.4 Keypad Navigation	25
17.4.1 Basic Keypad Control	25
17.4.2 Local / Remote Function	25
17.4.3 Setting Parameters b (Basic) and A (Advanced)	26
18.0 Control Mode Selection	27

Cont.

19.0 b (Basic) and A (Advanced) parameters defined	28
19.1 b (Basic) Parameter Summary	28 - 29
19.2 b (Basic) Parameter Details	30 - 33
19.3 A (Advanced) Parameter Summary	34 - 45
19.4 A (Advanced) Parameter Details	46 - 80
20.0 Option Modules and Cables	81
Fig. 20.1 Remote Keypad	81
Fig. 20.2 Remote Keypad Mounting Dimensions	82
Fig. 20.3 RS485 Interface P/N SIF-485	82
Fig. 20.4 RS232 Interface P/N SIF-232	83
Fig. 20.5 Copy Module P/N SIF-MP	83
21.0 Error Display Codes	84
21.1 Unresettable / Unrecoverable Errors	84
21.2 Automatically and Manually Recoverable Errors	84 - 85
21.3 Manually Recoverable Errors Only (no auto-restart)	86
21.4 Set –up Configuration and Interface Errors	86 - 87
21.5 Keypad Errors	87 - 88
22.0 Troubleshooting	88
22.1 General troubleshooting	89
Flow Charts:	90 - 96
Fig. 22.1 Fault display troubleshooting	90 - 91
Fig. 22.2 OC and OL fault troubleshooting	92
Fig. 22.3 OV and LV fault troubleshooting	93
Fig. 22.4 Motor will not run	94
Fig. 22.5 Motor overheating	95
Fig. 22.6 Instability	95
23.0 Routine periodic inspection	96
Appendix A – Specifications	A1
AA.1 General Specifications	A1 – A2
AA.2 Product (Model) Specifications	A3 – A4
Appendix B - Motor Internal Data List	B1
Appendix C - VCM Envelope Dimensions and Weight Table vs Model No	C1
Appendix D –VCM Cover Removal Procedure for Various Frame Sizes	D1 – D2
AD.1 Frame sizes 1 & 2	D1
AD.2 Frame size 3	D1
AD.3 Frame size 4	D2
AD.4 Frames sizes 5 & 6	D2
Appendix E- Inverter Parameter Setting List	E1
Appendix F- Version 1.2 Changes	F1 – F2

1.0 Introduction

The **VCM Inverter** series is state of the art design using the latest control and power technologies. It is designed to operate and control 3Ø induction motors in the hp range of *0.5 to 75 hp* and voltage class of *230 or 460VAC*. The inverter can operate in the *open loop vector, variable torque, or V/F mode*; settable via programming. There are two sets of parameters: **b** Basic, and **A** Advanced, allowing for flexible control in many different applications. The membrane keypad in combination with a 3 digit 7 segment display allows for ease of programming and monitoring.

An optional communications module can be used for control and parameter setting using the MODBUS RTU protocol. The **VCM** has been designed with easy access to the input power, output motor, and control terminals.

*Before proceeding with the set-up and installation please take time to review this manual to ensure proper operation and above all else, **personnel safety**.* Should there be any problem in using the product that cannot be resolved with the information provided in the manual, please contact your nearest Motortronics distributor or sales representative for assistance.

SAFETY FIRST!

The inverter is an electrical product. For your safety, there are symbols “Danger” and “Caution” in this manual as a reminder to pay attention to safety instructions on handling, installing, operating, and troubleshooting the inverter. Be sure to follow the instructions for maximum safety.



DANGER - Indicates a potential hazard that could cause death or serious personal injury.



CAUTION - Indicates that the inverter or the mechanical system might be damaged.



DANGER

- **Do not** touch any circuit boards or components while the *charge indicator* is still on after power is turned off. Wait until the *charge indicator* lamp is completely **extinguished**. **NOTE:** *The charge indicator lamp is located under the digital operator*
- **Do not** connect or disconnect any wiring while power is present.
- **Do not** test parts and signals on the circuit boards during the inverter operation.
- **Do not** disassemble the inverter and modify any internal wires, circuits, or parts.
- Ensure that the ground terminal of the inverter is bonded properly to earth ground. *For 200V class, ground to <100 Ω. For 400v class, ground to <10Ω.*



CAUTION

- **Do not** perform high voltage dielectric tests on any inverter parts, as damage to these parts may result.
- **Do not** connect the AC input power supply to the motor terminals T1 (U), T2 (V), and T3 (W) of the inverter.
- **Do not** touch any circuit board without proper precautions as the CMOS ICs on the inverter's control board can be damaged due to static electricity.

2.0 Product Inspection

MOTORTRONICS's inverters have all passed a functional factory test before delivery. Please check the following when you receive and unpack the inverter:

- Check for any damages that may have occurred during transportation or handling. If there is damage, **do not apply power**, and contact a MOTORTRONICS sales representative.
- Check that the model and capacity of the inverter are the same as those specified in your purchase order. The following describes the nameplate information.

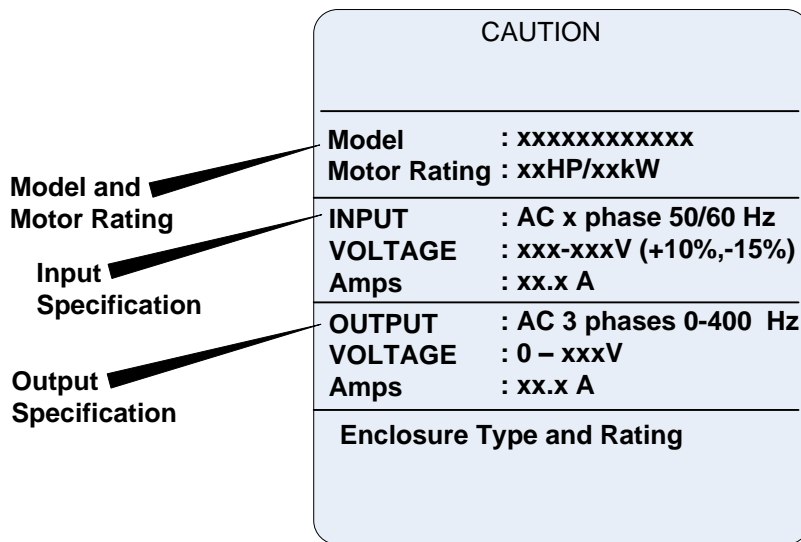

2.1 Nameplate Layout

NOTES:

3.0 Operating Precautions

3.1 Before Power Up



CAUTION

The input voltage must comply with the inverter's specified input voltage. (See product nameplate)



DANGER

Make sure the applied voltage input connections are correct, L1 (L), L2, and L3 (N) are **power-input** terminals and must not be connected to T1, T2, and T3. Otherwise, inverter damage can result.



CAUTION

- To avoid the front cover from disengaging or other physical damage, do not carry the inverter by its cover. Support the unit by its heat sink when transporting. Improper handling can damage the inverter or injure personnel, and should be avoided.
- To avoid the risk of fire, do not install the inverter on or near flammable objects. Install on nonflammable objects such as metal surfaces.
- If several inverters are placed in the same control panel, provide adequate ventilation to keep the temperature below 40°C (104°F) to avoid overheating or fire.
- When removing or installing the digital operator, turn off the power first, and then follow the instructions in this manual to avoid operator error or loss of display caused by faulty connections.

Warning

This product is sold subject to IEC 61800-3. In a domestic environment this product may cause radio interference in which case the user may be required to apply corrective measures.



CAUTION

To ensure the safety of peripheral devices, it is strongly recommended to install a fast acting fuse on the power input side of the inverter. The specifications for fast acting fuses are covered in Section 12.0.

3.2 During Power up

DANGER

- **Do not** connect or disconnect any wiring on the inverter as bodily harm and / or damage to the equipment may result.
- When momentary power loss is greater than **2** seconds (*the higher the HP rating, the longer the time*), the inverter can not sustain power to the control circuit. Therefore, when power is restored, the operation of the inverter is based on the setup of b000 / A015 and the condition of the external switches. This is considered to be a restart.

When **restarting**, the operation of the inverter is based on the setup of b000 and A015 and the condition of external switch (FWD / REV button).

NOTE: the start operation is not affected by parameters A013/A014/A018/A019.

 1. When b000=0000, the inverter **will not run** after restart.
 2. When b000=0001 and the external (FWD / REV) switch is off, the inverter **will not run** after restart.
 3. When b000=0001, the external switch (FWD / REV button) is on, and A015=0000, the inverter **will run** automatically after restart. **In this case after loss of power, turn off the external (FWD/REV) switch to avoid damage to the equipment and injury to personnel after sudden restoration of power.**

For further information, please refer to the description and warnings of parameter A015 covered in the advanced parameter section.
- When the momentary power loss is less than **2** seconds, the inverter still has enough storage power to support the control the circuit. Therefore, when power is restored, the inverter will automatically restart depending on the setup of A013 / A014.

CAUTION

The inverter display will flash the power voltage set by A007 for 5 seconds after power is applied.

3.3 Before Operation

DANGER

Make sure the model and inverter capacity match the A175 setting. See Section 17.0 for help in navigating parameters.

3.4 During Operation

 **DANGER**

Do not connect or disconnect the motor during operation. The overcurrent circuit will cause the inverter to trip or damage the equipment may result.

 **DANGER**

- **Do not** remove any protective covers as lethal voltages are present inside the inverter.
- The motor will restart automatically after stop when the auto-restart function is on. In this case, use extreme **caution** while working near the motor or driven equipment.
- *Note: The stop function is different from the **emergency stop switch**, which must be set first to be effective.*

 **CAUTION**

- **Do not** touch heat-generating components such as heat sinks and braking resistors.
- The inverter can operate the motor from low speed to high speed. Verify that the allowable speed range of the associated machinery will tolerate this range.
- Note the settings related to the `minimum braking resistor value.
- Do not check signals on circuit boards while the inverter is operating.

 **CAUTION**

After power is removed from the inverter, allow **5 minutes** before disassembling or checking any components or disconnecting wiring. The charge indicator lamp which is located under the digital operator should **not** be illuminated.

4.0 Environment and Installation

The environment will directly affect the proper operation and the life span of the inverter. To ensure that the inverter will give maximum service life, please comply with the following environmental conditions:

<ul style="list-style-type: none"> Ambient Temperature: 14 -104 °F (-10°C - +40°C), Without Cover: 14-122 °F (-10°C - +50°C) Relative Humidity: 95% non-condensing 	
<ul style="list-style-type: none"> Altitude : < 3,281 ft. (1000m) 	
<ul style="list-style-type: none"> Avoid exposure to rain or moisture. 	<ul style="list-style-type: none"> Avoid direct sunlight.
<ul style="list-style-type: none"> Avoid oil mist and salinity. 	<ul style="list-style-type: none"> Avoid corrosive liquid and gas.
<ul style="list-style-type: none"> Avoid dust, lint fibers, and small metal filings. 	<ul style="list-style-type: none"> Keep away from radioactive and flammable materials.
<ul style="list-style-type: none"> Avoid electromagnetic interference (soldering machines, power machines). 	
<ul style="list-style-type: none"> Avoid vibration (stamping, punching machines etc.). Add a vibration-proof pad if the situation cannot be avoided. 	
<ul style="list-style-type: none"> If several inverters are placed in the same control panel, provide a heat removal means to maintain ambient temperatures below 40°C. 	

4.1 Inverter Mounting

When mounting and installing one or more inverters on a panel or in an enclosure, ensure that the placements and clearances are correct. (see Fig.'s 4.1.1 and 4.1.2). Also make sure that the inverter(s) are mounted **vertically** to maximize air flow to the heatsink. To further increase airflow, the dust cover on the inverter(s) may be removed, provided that the environment is free from contaminants.

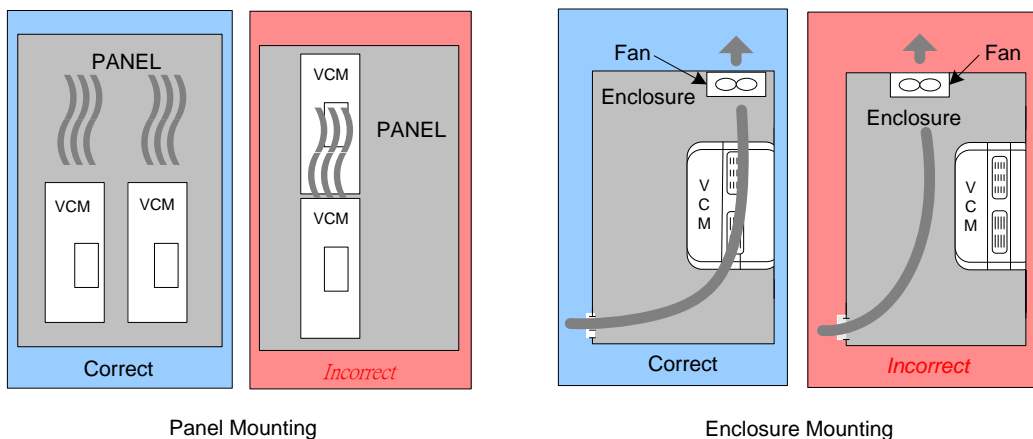

Fig. 4.1.1 Panel and Enclosure Placements

Cont.

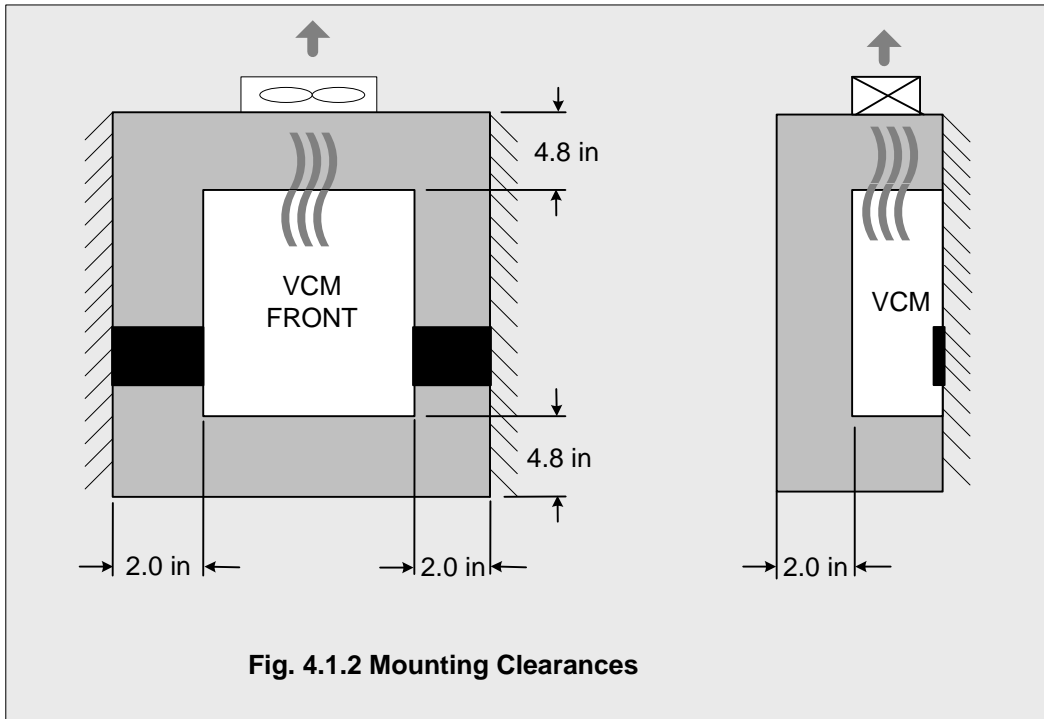
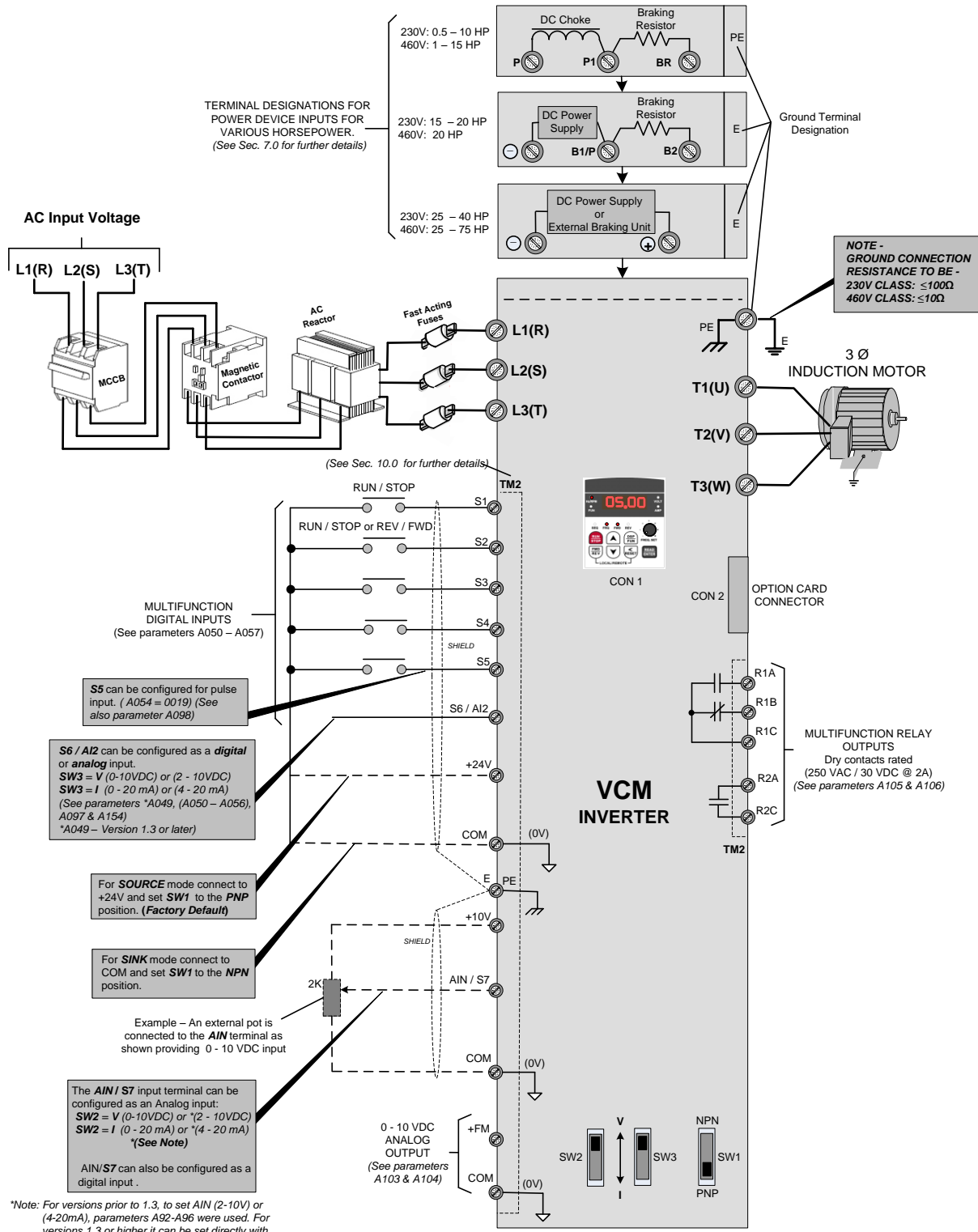

Fig. 4.1.2 Mounting Clearances

NOTES:

5.0 General Wiring Diagram 1 - 2 HP and (3 – 75 HP prior to Version 1.3)



VCM General Wiring Diagram
1 - 2 HP and (3-75 HP prior to Version 1.3)

*Note: For versions prior to 1.3, to set AIN (2-10V) or (4-20mA), parameters A92-A96 were used. For versions 1.3 or higher it can be set directly with parameter A154. Also see parameters A050 - A056.

6.0 General Wiring Diagram (3 – 75 HP Version 1.3 or later)

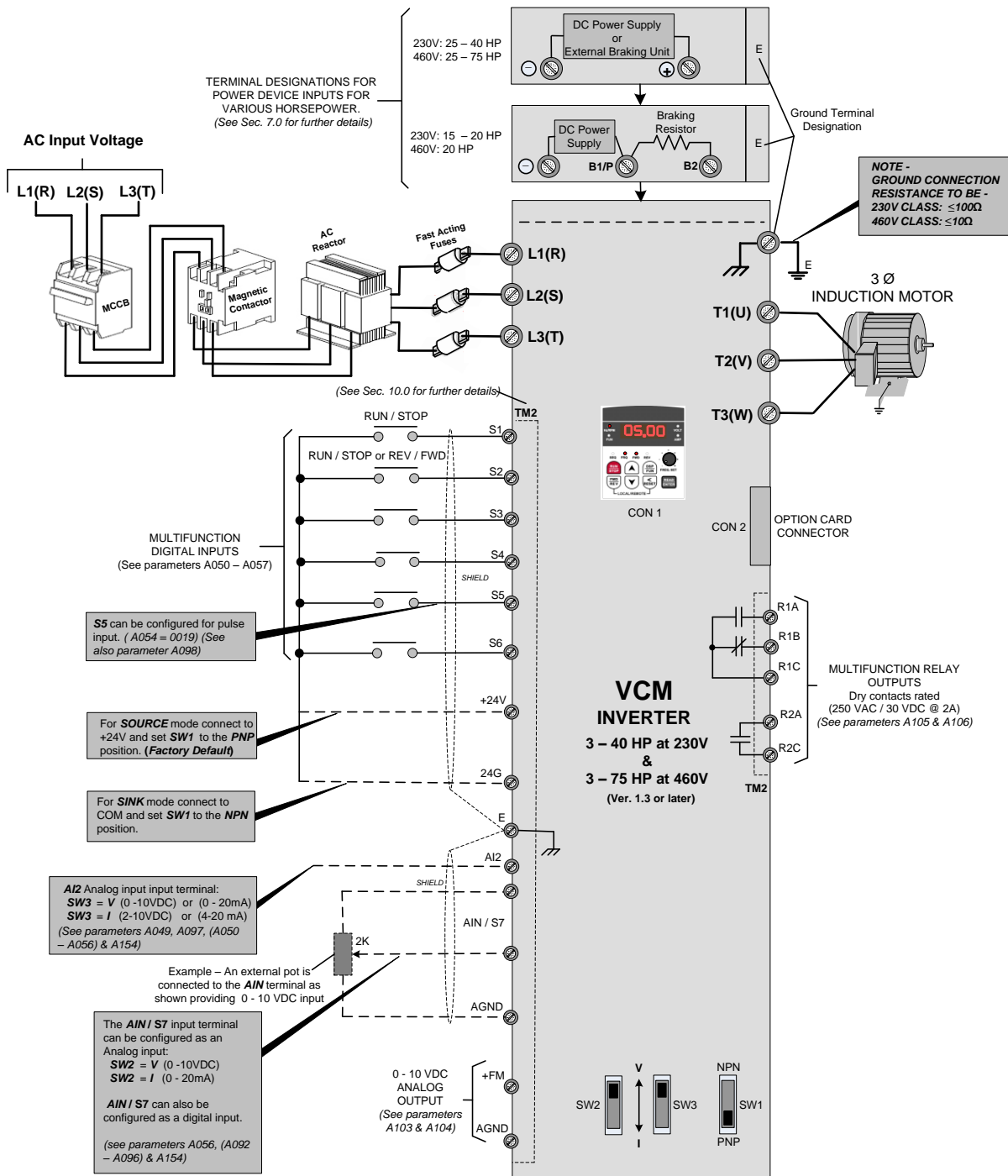

VCM General Wiring Diagram
 3 – 40 HP at 230V and 3 – 75 HP at 460V (Version 1.3 or later)

7.0 Power Terminals Designations and Ratings (Terminal Block TM1)

Depending on inverter ratings, the power terminals (TM1) can have one of three configurations. These are shown as A), B) and C) in Fig. 7.1. Section 7.2 covers the electrical ratings and tightening torques of the terminals.

- **Do Not** over tighten terminal screws. (See Sec. 7.2)
- Use the proper wire size for terminal connections.
- Use proper termination techniques.

7.1 Power Terminal Configuration TM1

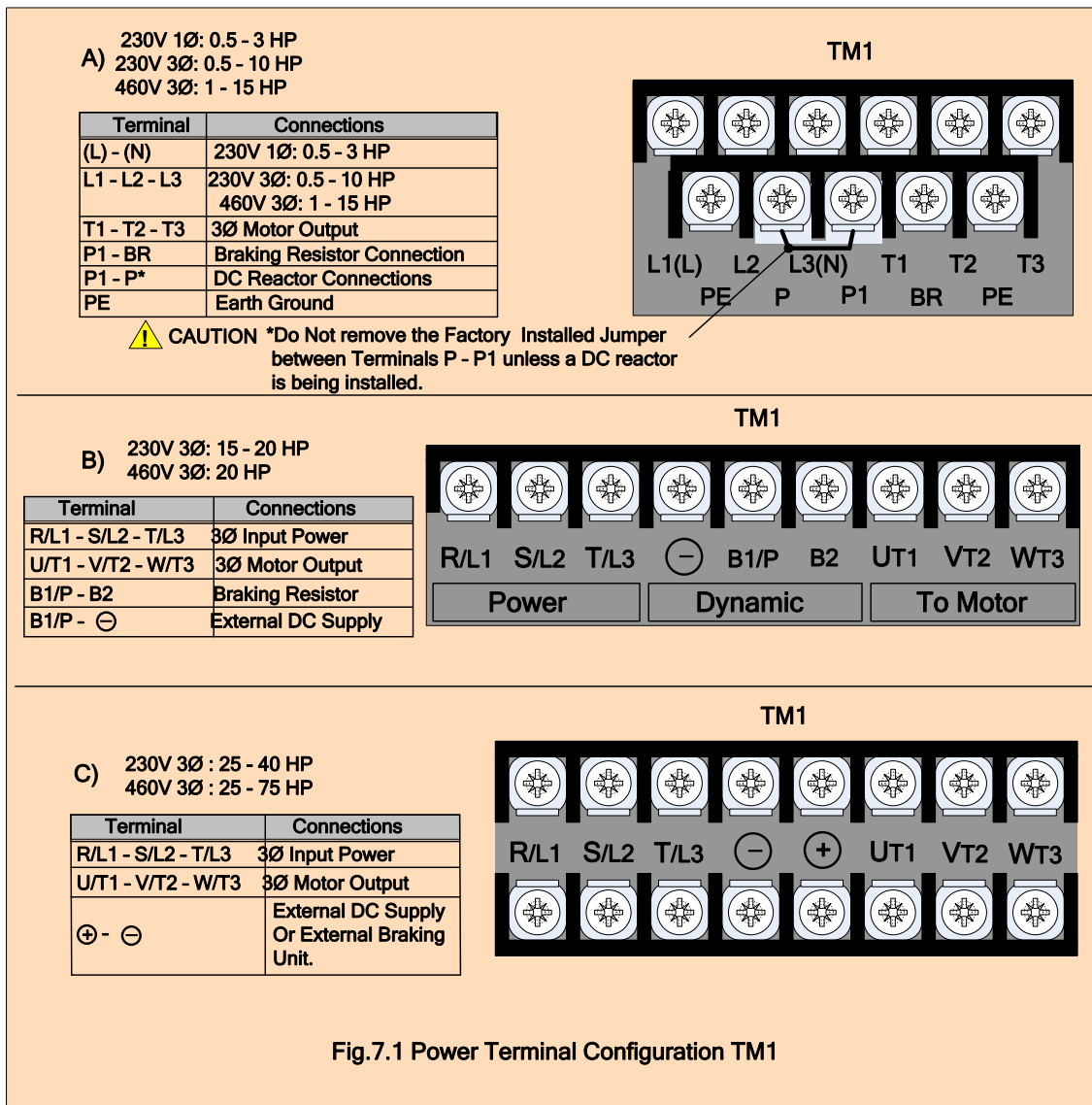

7.2 Power Terminal Block TM1 Electrical Ratings and Tightening Torques

Table 7.1 Electrical Ratings and Tightening Torques

Horsepower	Phase Ø	Power source	Volts	Amps	Tightening Torque	
					Lb-ft / KG-M	Lb-in / KG-CM
0.5 & 1	1	200-240V	600	15A	0.59 / 0.08	7.10 / 8.20
2	3					
1 & 2	3					
3, 5, 7.5, 10 & 15	3	200-240V		40A	1.5 / 0.21	18.00 / 20.28
2 & 3	1					
3, 5, 7.5, 10 & 15	3	380-480V		80A	1.84 / 0.3	22.1 / 30
15, 20, & 25	3	200-240V				
20, 25, & 30	3	380-480V		60A	1.84 / 0.3	22.1 / 30
30	3	200-240V				
40 & 50	3	380-480V		100A	4.42 / 0.66	53.1 / 66
40	3	200-240V				
60 & 75	3	380-480V	150A			

8.0 Inverter Wiring

8.1 Input / Output Power Wiring Connections (Terminal TM1)

Table 8.1 Input / Output Power Wire Size vs Horsepower

Inverter Input Voltage	Horsepower						
	240 V	0.5, 1, & 2	3 & 5	7.5 & 10	X	15, 20, & 25	30
480 V	1, 2, 3, & 5	7 & 10	15	20, 25 & 30	X	40 & 50	60 & 75
*AWG / mm ²	#14 / 2.0	#12 / 3.5	#10 / 5.5	#6 / 14	#4 / 22	#2 / 30	#1 / 50

* Wire size shown is based on maximum terminal size. Please consult the NEC or local codes for the proper size to be used.

- Use **only** copper wires. Proper diameter wire should be based on ratings at +105°C.
- The minimum voltage rating of wiring is: 300V for 230VAC and 600V for 460VAC.
- For safety reasons do not use under sized wiring.

8.2 Input / Output Power Wiring Noise Suppression

Electrical noise or EMI can be generated from the input power lines and or the output power leads to the motor. This can interfere with the function of surrounding equipment as well as the inverter’s own control wiring. Fig. 8.2 shows an example of filters and shielding schemes to help minimize any radiated EMI.

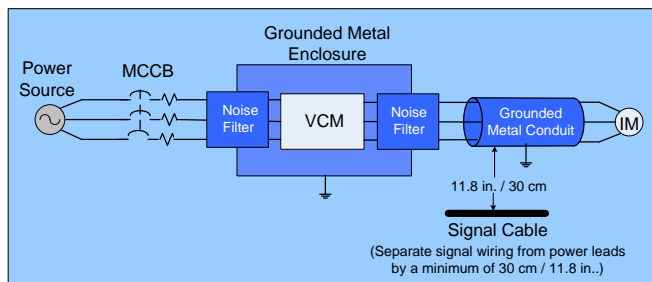

Fig. 8.2 Input / Output Power Wiring Noise Suppression

Cont.

8.6 Input Power Wiring and Installation Recommendations with Examples

Fig. 8.6 shows input power installation recommendations with correct and incorrect examples.

- When possible the inverter should be connected to a dedicated input power source. (Fig. 8.6 a)
- When the inverter is sharing a power source with other equipment, either install a special input noise filter, (Fig. 8.6b) or an isolation transformer, (Fig. 8.6c) to isolate other loads.
- Using a general purpose noise filter may not give sufficient results as shown in (Fig. 8.6d) below.

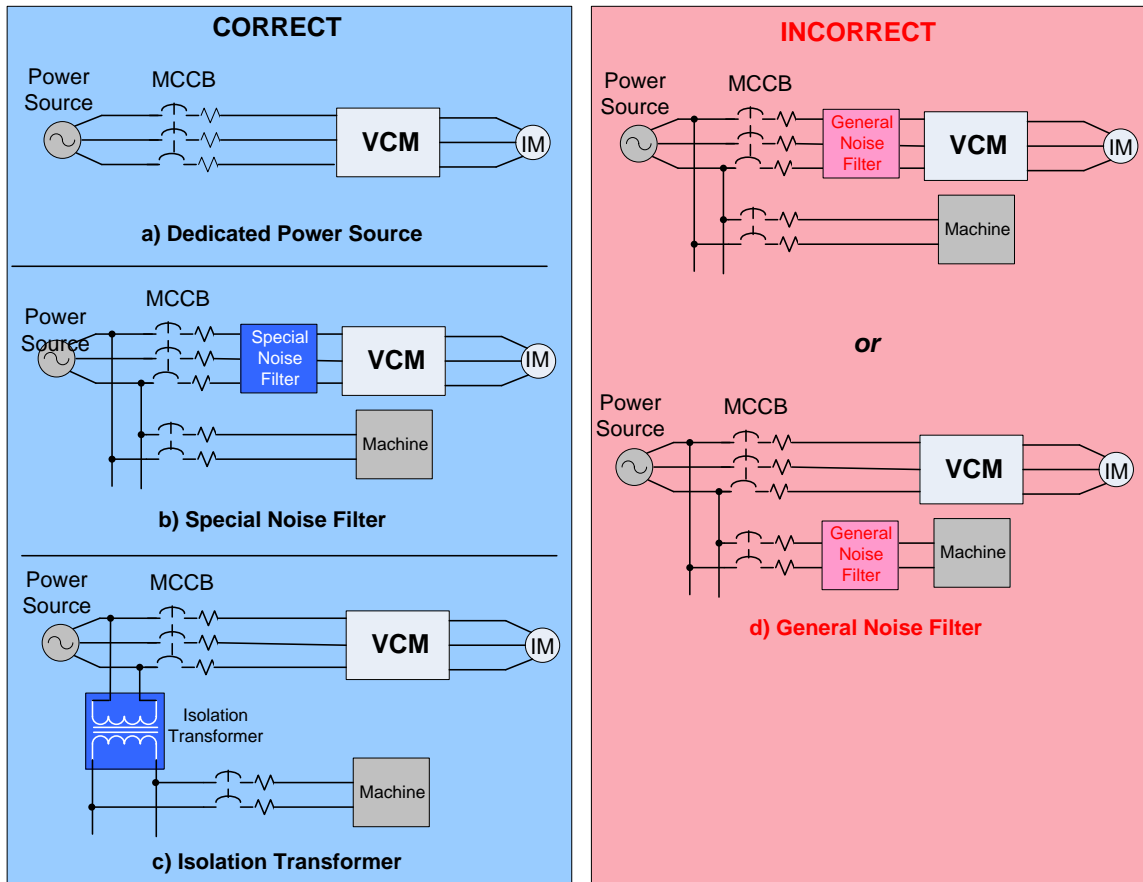

Fig. 8.6 Input Power Wiring and Installation Examples

9.0 Input / Output Power Section Block Diagram

The following Fig. 9.0 A), B) and C) show the basic configuration of the power sections for the range of horsepower and input voltages. This is shown for reference only and is not a detailed depiction.

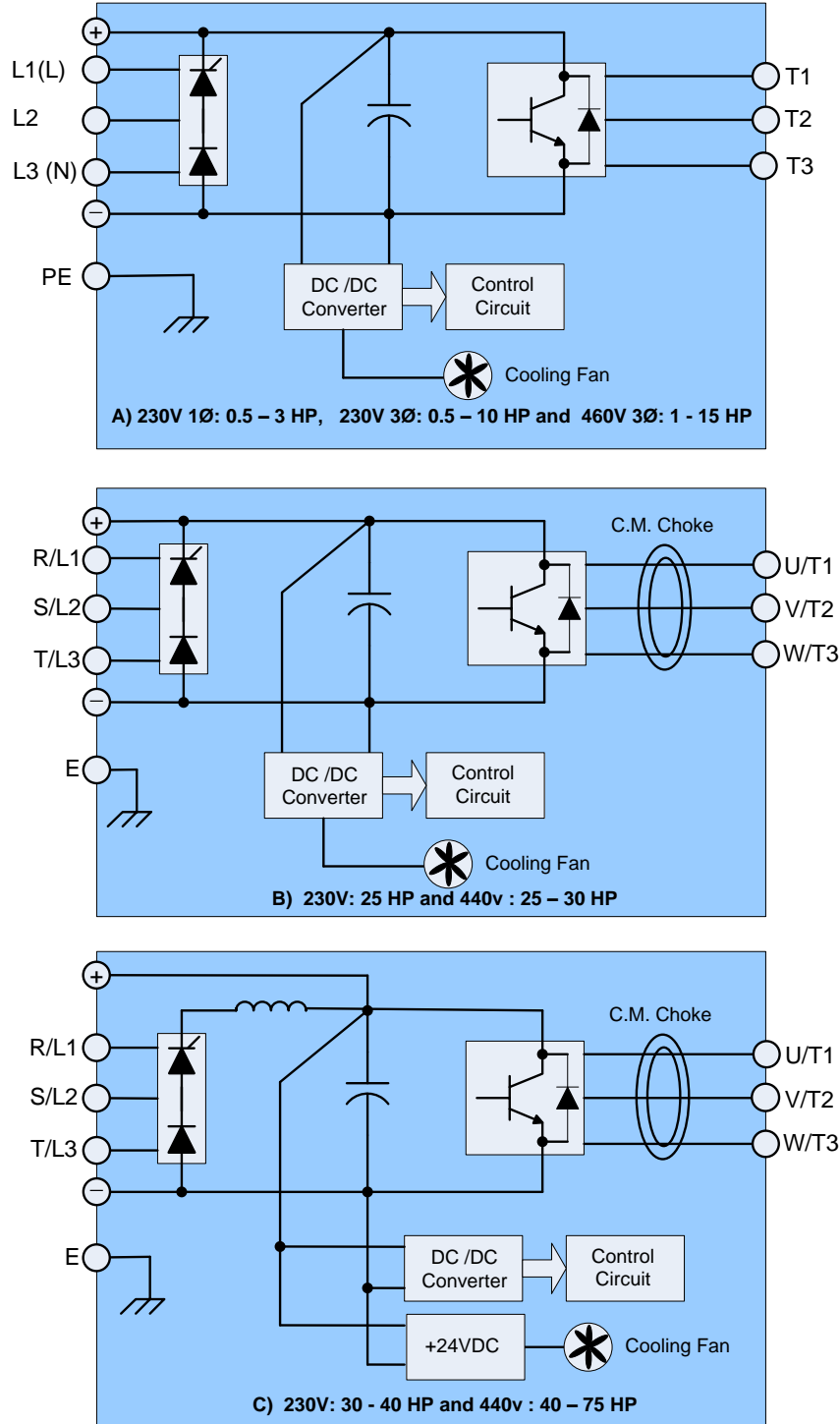

Fig. 9.0 Power Input / Output Block Diagrams

10.0 Control Terminals (Terminal Block TM2)

The following table shows the control terminal designations for terminal block TM2. Refer to the parameter section of this manual and to General Wiring Diagrams 5.0 and 6.0 for further explanation of the functions and connections.

Table 10.1 Control Terminal Designations (Terminal Block TM2)

Terminal	Description	
R2A	Multifunctional output relay (<i>Form A - N.O.</i>)	
R2B		
R1C	Common contact	Multifunctional output relay (<i>Form C</i>)
R1B	Normal close contact	
R1A	Normal open contact	
10V	Frequency knob (VR) power source terminal, 10mA max. Do not apply external loads.	
AIN / S7	Analog signal input terminal (0 -10Vdc / 4 - 20mA), or multifunction input terminals S7 (H level:>8V, L level:<2V, PNP only) (refer to parameter A056 description)	
AI2	Analog signal input (0 - 10V / 0 – 20 mA) Or 2 – 10V / 4 – 20 mA) 3 - 75 HP: (For Ver. 1.3 or later only)	
24V	Common for digital inputs, S1-S5 (S6, S7) in PNP (Source) input. (<i>SW1 is set to PNP input</i>) 10mA max. Do not apply external loads.	
COM	0.5 - 2 HP & (3 – 75HP prior to Ver. 1.3): Common for analog input /output signals and for digital S1 - S5 inputs in NPN (Sink) input. (<i>SW1 set to NPN input</i>)	
*24G	Common for digital S1 – S6 inputs in NPN (Sink) input. (<i>SW1 set to NPN input</i>)	
*AGND	Common for analog inputs AIN & AI2 and analog output FM+	
FM+	Multifunction analog output signal, 0-10VDC @ 2mA max. (refer to parameter A103 description)	
S1	Multifunction digital input terminals(refer to parameters A050 - A054 description)	
S2		
S3		
S4		
S5	Multifunction digital input terminal (Same as S1 – S4) or can be used as a pulse train input to control output frequency. (refer to parameter A054=0019 description). Input pulse level 19.2V min. to 24.7V max.	
S6 / AI2	0.5 - 2 HP& (3 – 75HP prior to Ver. 1.3): Multifunction input terminal (digital terminal high level:>8V, Low level:<2V, PNP only) or analog input terminal AI2 (0 -10Vdc / 4 - 20mA). (refer to A055 description)	

* 3 - 75 HP: (For Ver. 1.3 or later only, see Appendix F for further details)

Cont.

10.2 Control Terminal Layout (Terminal Block TM2) and Control Switches

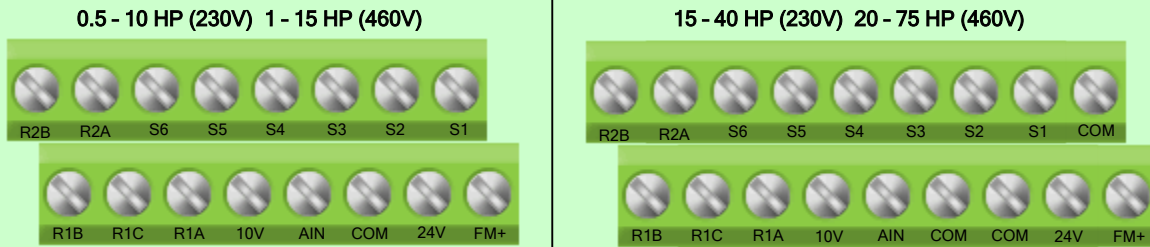

Fig. 10.2.1 Control Terminal TM2 Layout (Prior to Version 1.3)

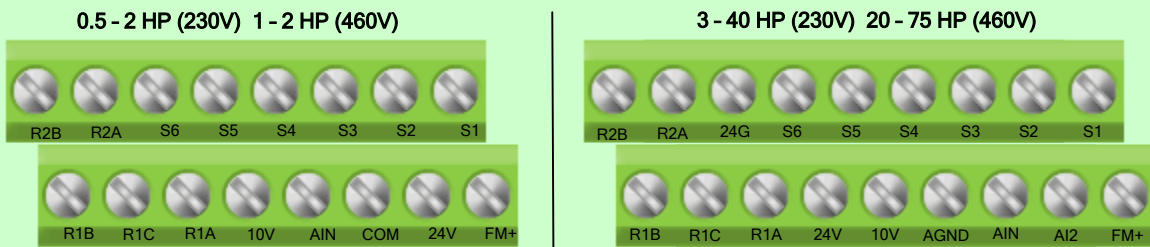
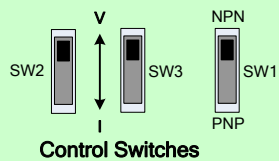

Fig. 10.2.2 Control Terminal TM2 Layout (Version 1.3 or Later)



SW1 - Sets the input digital terminals **S1-S7** for Sink (NPN) or Source (PNP) logic.

SW2 - Sets the analog input terminal **AIN** for voltage (V) or current (I).

SW3 - Sets the analog input terminal **AI2** (Ver. 1.3 or later) or the multifunctional terminal **S6/AI2** (prior to Ver.1.3) for voltage (V) or current (I).

Please refer to General Wiring Diagrams 5.0 and 6.0 for further information.

Control Board

10.3 Control Terminal Wiring and Connections (Terminal TM2)

Control wiring is connected to terminal TM2. Select the proper wire and rating in accordance with the following:

- Use copper wire **only**. The proper wire diameter should be based on ratings at +105°C.
- AWG #18 is recommended.
- To minimize EMI (*electromagnetic interference*), route control cables at least 12 in. from any power cables. **Do not** run control wiring in the same conduit with power and motor wiring.
- Depending on signal levels, shielded - twisted pair wiring is recommended as shown in the Fig. below.
- For nominal values of input / output signals, follow the requirements of *class 2* wiring

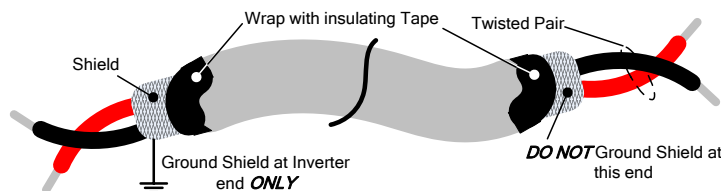

Control Cable, Shielded Twisted Pair

11.0 Peripheral Power Devices

The following describes some of the precautions that should be followed when selecting peripheral power devices.

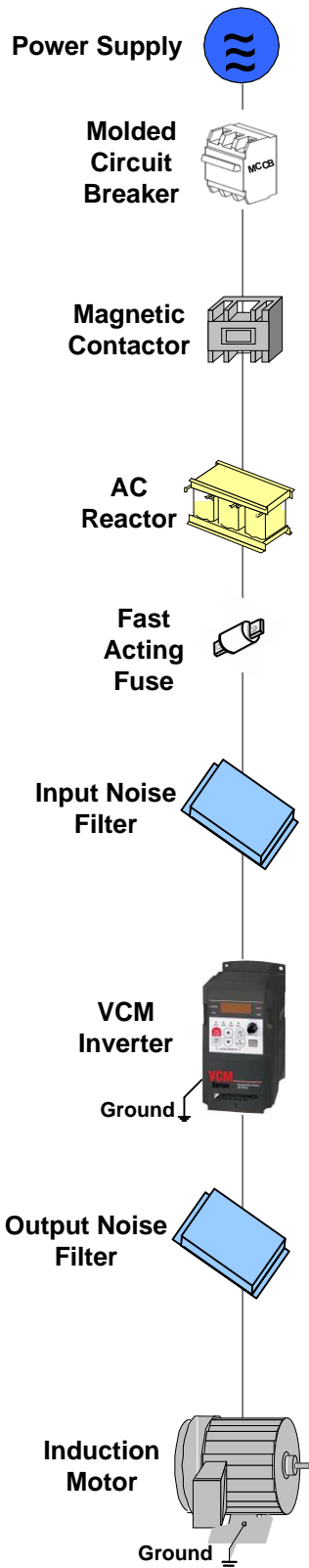

Power supply:

-  Make sure the correct voltage is applied to avoid damaging the inverter.

Molded-case circuit breaker (MCCB) or fused disconnect:

- A molded-case circuit breaker or fused disconnect must be installed between the AC source and the inverter that conforms to the rated voltage and current of the inverter to control the power and protect the inverter.

-  Do not use the circuit breaker as the run/stop switch for the inverter.

Ground fault detector / breaker:

-  Install a ground fault breaker to prevent problems caused by current leakage and to protect personnel. Select current range up to 200mA, and action time up to 0.1 second to prevent high frequency failure.

Magnetic contactor:

- Normal operations do not need a magnetic contactor. When performing functions such as external control and auto restart after power failure, or when using a brake controller, install a magnetic contactor.

-  Do not use the magnetic contactor as the run/stop switch for the inverter.

AC line reactor for power quality:

- When inverters are supplied by a high capacity (above 600KVA) power source, an AC reactor can be connected to improve the power factor.

Install Fast Acting Fuse:

- To protect peripheral equipment, install fast acting fuses in accordance with the specifications in **Sec.12.0**.

Input and output noise filter:

- A filter must be installed when there are inductive loads affecting the inverter.

Inverter:

- Output terminals T1, T2, and T3 are connected to U, V, and W terminals of the motor. If the motor runs in reverse while the inverter is set to run forward, swap any two terminals connections for T1, T2, and T3.

-  To avoid damaging the inverter, do not connect the output terminals T1, T2, and T3 to AC input power.

-  Connect the ground terminal properly. (230V series: $R_g < 100\Omega$; 460V series: $R_g < 10\Omega$.)

12.0 Input Fuse Types and Ratings

Inverter input fuses are provided to disconnect the inverter from input power in the event of a component failure in the inverter’s power circuitry. The inverter’s electronic protection circuitry is designed to clear inverter output short circuits and ground faults without blowing the inverter input fuses. The table on the next page shows the VCM input fuse ratings.

- To protect the inverter most effectively, use fuse types RK5 or CC/T with a current-limit function.

Table 12.1A (1Ø) Input Fuse Types and Ratings

220V class (1Ø)						
VCM-2	HP	KW	KVA	100% CONT Output AMPS (A)	Max.RK5 FUSE Rating(A)	Max. CC or T FUSE Rating(A)
P5-1P	0.5	0.4	1.2	3.1	10	20
01-1P	1	0.75	1.7	4.5	15	30
02-1P	2	1.5	2.9	7.5	20	40
03-1P	3	2.2	4.0	10.5	25	50

Table 12.1B (3 Ø) Input Fuse Types and Ratings

220V class (3 Ø)						
VCM-2	HP	KW	KVA	100% CONT Output AMPS (A)	Max.RK5 FUSE Rating(A)	Max. CC or T FUSE Rating(A)
P5-P	0.5	0.4	1.2	3.1	8	10
01-P	1	0.75	1.7	4.5	12	15
02-P	2	1.5	2.9	7.5	15	20
03-P	3	2.2	4.0	10.5	20	30
05-P	5	3.7	6.7	17.5	30	50
07-P	7.5	5.5	9.9	26	50	60
10-P	10	7.5	13.3	35	60	70
15-N	15	11.0	20.6	48	80	100
20-N	20	15.0	27.4	64	100	125
25-N	25	18.5	34.0	80	125	150
30-N	30	22.0	41.0	96	160	200
40-N	40	30.0	54.0	130	200	250

NOTES:

Cont.

Table 12.1C (3 Ø) Input Fuse Types and Ratings

440V class (3 Ø)						
VCM-4	HP	KW	KVA	100% CONT Output AMPS (A)	Max.RK5 FUSE Rating(A)	Max. CC or T FUSE Rating(A)
01-P	1	0.75	1.7	2.3	6	10
02-P	2	1.5	2.9	3.8	10	15
03-P	3	2.2	4.0	5.2	10	20
05-P	5	3.7	6.7	8.8	20	30
07-P	7.5	5.5	9.9	13	25	35
10-P	10	7.5	13.3	17.5	30	50
15-P	15	11.0	20.6	25	50	60
20-N	20	15.0	27.4	32	60	70
25-N	25	18.5	34.0	40	70	80
30-N	30	22.0	41.0	48	80	100
40-N	40	30.0	54.0	64	100	125
50-N	50	37.0	68.0	80	125	150
60-N	60	45.0	82.0	96	150	200
75-N	75	55.0	110.0	128	200	250

NOTE: Fuse ratings are based on 250V fuses for 230V inverters and 600v for 460V inverters.

13.0 Applicable Specifications for Circuit Breakers and Magnetic Contactors

The following tables show the specifications for molded case circuit breakers and magnetic contactors vs VCM models.

Table 13.1A (230V)

VCM model	VCM-2XX - Y											
	P5-1P	01-1P	02-1P	03-1P	05-P	07-P	10-P	15-N	20-N	25-N	30-N	40-N
Thermal-Magnetic Breaker Max. Trip Setting	10A	20A	30A	30A	30A	50A	60A	100A	100A	150A	175A	175A

Table 13.1B (460V)

VCM model	VCM-4XX - Y												
	01-P/02-P/03-P/05-P	07-P	10-P	15-P	20-N	25-N	30-N	40-N	50-N	60-N	75-N		
Thermal-Magnetic Breaker Max. Trip Setting	15A	20A	30A	50A	50A	75A	100A	100A	125A	175A	175A		

⚠ CAUTION

Motortronics assumes no responsibility for failures caused by the following conditions:

- A SCPD (molded-case circuit breaker or fuse set) is not installed or an improper or overrated SCPD is used between the power source and the drive.
- A magnetic contactor, capacitor or surge arrestor is connected between the drive and the motor.
- Use of the drive with a three-phase AC induction motor that is larger than the capacity of the drive. "Inverter Duty" motors are preferable, especially on applications rated at 380V and above.
- If one drive is used to control several motors, the total current of all motors running simultaneously must be less than the rated current of the drive. And, each motor must be equipped with proper thermal overload protection (separate thermal overload relay for each motor). In this type of application, the VCM Series drive must be operated in V/Hz mode.
- Do not add capacitive components, such as phase capacitors (LC or RC) between the drive and the motor.

14.0 Reactor Input / Output Specifications

The specifications for the input (AC Power side) and output (DC to Motor side) reactors are as shown in the following tables.

Table 14.1 Input Reactor Specifications

VCM Model (240V)	AC inductance at AC input side		VCM Model (460V)	AC inductance at AC input side	
	Current (A)	Inductance (mH)		Current (A)	Inductance (mH)
2P5	5.0	2.1	401	2.5	8.4
201	5.0	2.1	402	5.0	4.2
202	10.0	1.1	403	7.5	3.6
203	15.0	0.71	405	10.0	2.2
205	20.0	0.53	407	15.0	1.42
207	30.0	0.35	410	20.0	1.06
210	40.0	0.265	415	30.0	0.7
215	60.0	0.18	420	40.0	0.53
220	80.0	0.13	425	50.0	0.42
225	90.0	0.12	430	60.0	0.36
230	120.0	0.09	440	80.0	0.26
240	160.0	0.07	450	90.0	0.24
			460	120.0	0.18
			475	150.0	0.15

Table 14.2 Output Reactor Specifications

VCM Model	AC inductance at input side	
	Current (A)	Inductance (mH)
(240V)		
2P5	3.1	5.65
201	4.5	3.89
202	7.5	2.33
203	10.5	1.67
205	17.5	1.00
207	26	0.67
210	35	0.50
(460V)		
401	2.3	15.22
402	3.8	9.21
403	5.2	6.73
405	8.8	3.98
407	13	2.69
410	17.5	2.00
415	25	1.40

15.0 Braking Resistor Selections

VCM Inverter Model	Braking Resistor per braking unit	Suitable Motor Capacity		Braking resistor Specification		Braking resistor Duty Cycle (%)	Braking torque (%)	Resistor dimension (L x W x H) inches (mm)
	Type	(HP)	(KW)	(W)	(Ω)			
2P5	JNBRN-201	0.5	0.4	150	200	10	238	9.88x1.10x2.36 (251x28x60)
201	JNBRN-201	1	0.75	150	200	10	119	9.88x1.10x2.36 (251x28x60)
202	JNBRN-202	2	1.5	150	100	10	119	9.88x1.10x2.36 (251x28x60)
203	JNBRN-203	3	2.2	260	70	10	115	10.79x1.34x3.07 (274x34x78)
205	JNBRN-205	5	3.7	390	40	10	119	10.79x1.34x3.07 (274x34x78)
207	JNBRN-208	7.5	5.5	520	30	10	108	15.7x1.57x3.94 (400x40x100)
210	JNBRN-210	10	7.5	780	20	10	119	15.7x1.57x3.94 (400x40x100)
215	JNBR-2R4KW13R6	15	11	2400	13.6	10	117	21.1x1.96x4.33 (Qty 2) (535x50x110)
220	JNBR-3KW10	20	15	3000	10	10	119	24.2x1.96x4.33(Qty 2) (615x50x110)
401	JNBRN-401	1	0.75	150	750	10	126	9.88x1.10x2.36 (251x28x60)
402	JNBRN-402	2	1.5	150	400	10	119	9.88x1.10x2.36 (251x28x60)
403	JNBRN-403	3	2.2	260	250	10	126	10.79x1.34x3.07 (274x34x78)
405	JNBRN-405	5	3.7	400	150	10	126	10.79x1.34x3.07 (274x34x78)
407	JNBRN-408	7.5	5.5	600	130	10	102	15.7x1.57x3.94 (400x40x100)
410	JNBRN-410	10	7.5	800	100	10	99	24.2x1.96x4.33 (615x50x110)
415	JNBR-1R6KW50	15	11	1600	50	10	126	24.2x1.96x4.33 (615x50x110)
420	JNBR-1R5KW40	20	15	1500	40	10	119	24.2x1.96x4.33 (615x50x110)

A- Alternative selection choice: 450: (JNTBU-430 + JNBR-4R8KW32) × 2 460: (JNTBU-430 + JNBR-4R8KW27R2) × 2
 *Above 20HP, braking transistor units are required, these are **not** available from Motortronics.

Formula for braking resistor: $W = (V_{pnb} * V_{pnb}) * ED\% / R$

- Where: **W** = braking resistor power rating (Watts)
- V_{pnb}** = Braking voltage (220V=380VDC, 440V=760VDC)
- ED%** = Braking effective period (Braking time / total cycle time x 100%)
- R** = Braking resistor value (ohms)

For further detailed information, please contact **MOTORTRONICS**.

16.0 EMC Filters

The inverters use PWM (Pulse Width Modulation) in the output power section which results in rapid on / off switching of the solid state power devices (IGTB transistors).

Because of this, unwanted EMI (Electromagnetic Interference) and RFI (Radio Frequency Interference) is produced which may affect other equipment.

EMC filters available from independent suppliers may be used to control this interference within limits set forth by the following standards:

- EMC Standard 89/336/EEC
- EMI Radio Standard – EMS Immunity Standard
- EN 61800-3 1996/A11 : 2000 First Environmental Unrestricted Distribution (Class B)
- EN 61800-3 1996/A11 : 2000 First Environmental Restricted Distribution

17.0 Keypad Key Functions and Navigation

The VCM keypad, provides all the necessary functions to allow full control of the VCM inverter. The keypad has membrane type keys and a 7 - segment 4 - digit LED display. Also located on the keypad is a potentiometer that can be used to control inverter output frequency when selected as the control source. A **remote** keypad is available as an **option**, and is covered more in detail in the **Option Modules Sec. 20.0**.

17.1 VCM Keypad

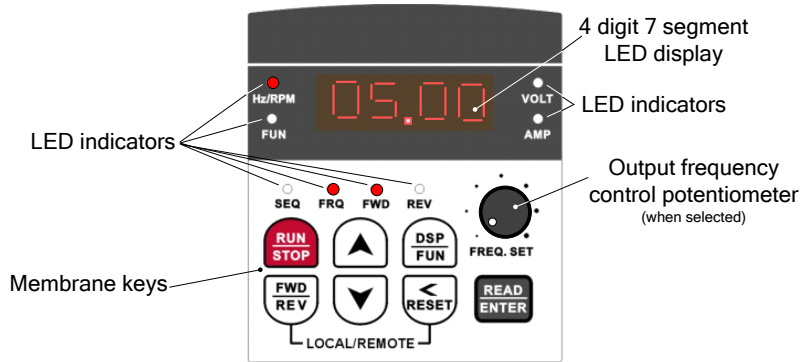

Fig. 17.1 VCM Keypad

17.2 Keypad LED Functions

Table 17.1







LED	STATUS	DESCRIPTION
SEQ (Sequence)	OFF	Run Command Source is from the <i>keypad</i> (B000=0) (factory default)
	ON	Run Command Source is from <i>external terminal</i> (B000=1), or <i>RS485 communication control</i> (B000=2)
FRQ (Frequency)	OFF	Frequency Command Source is from the <i>keypad</i> (B004=0) (factory default)
	ON	Frequency Command Source is from <i>potentiometer on keypad</i> (B004=1), <i>external analog signal</i> (B004=2), <i>up / down frequency control using MFIT (S1-S6)</i> (B004=3) or <i>RS485 communication control</i> (B004=4)
*FWD (Forward)	ON	Drive is running in the <i>forward</i> direction
	Flashing	Drive is in the <i>stop mode</i>
REV (Reverse)	ON	Drive is running in the <i>reverse</i> direction
	Flashing	Drive is in the <i>stop mode</i>
FUN (Function)	ON	Entering <i>A</i> or <i>b</i> parameters
*Hz/RPM	ON	Display is showing <i>output frequency</i>
VOLT	ON	Display is showing <i>motor voltage</i> (B014=1), <i>DC bus voltage</i> (B015=1) or <i>PID feedback voltage</i> (B016=1)
AMPS	ON	Display is showing <i>motor current</i> (B013=1)

*Note – On initial powerup (factory default), the only LEDs that are on are Hz/RPM and FWD.

17.3 Key Functions

The keys are multifunctional, providing for both control of the inverter *when keypad mode is selected (default)* and access in setting various parameters. The key functions are as follows.

Table 17.2

	<p>UP / DOWN</p> <ul style="list-style-type: none"> • Sets the inverter output frequency when using the keypad mode. • Sets the value of the 4 display digits to set the *A and b parameters. * Access to the A parameters must be enabled. (see Sec. 17.4.3)
	<p>RUN / STOP</p> <ul style="list-style-type: none"> • Controls the output of the inverter when selected in the keypad mode. It is an on / off toggle function.
	<p>DISPLAY / FUNCTION</p> <ul style="list-style-type: none"> • Toggles the display between the inverter output selected value (Hz etc.) and the *A and b parameter lists. Also when AMPS and or VOLTS are selected for display, the key will sequence through to display Hz/RPM, A and b parameter lists, AMPS or VOLTS.
	<p>FWD / REV</p> <ul style="list-style-type: none"> • Controls the direction of the motor (inverter output) when selected in the keypad mode. It is an on / off toggle function. • Used in conjunction with the RESET / SCROLL key to toggle between Local and Remote operation.
	<p>RESET / SCROLL</p> <ul style="list-style-type: none"> • Resets the inverter after a fault • Scrolls through the position of the 4 display digits to set the *A and b parameters. • Used in conjunction with the FWD / REV key to toggle between Local and Remote operation.
	<p>READ / ENTER</p> <ul style="list-style-type: none"> • Used to READ and /or save (ENTER) *A and b parameters.

 **CAUTION**

Do not use any sharp or potentially damaging objects to operate the keypad.

NOTES:

17.4 Keypad Navigation

When attempting to control and set various parameters for the inverter it would be useful for the user to become familiar with keypad navigation and to go through a few function changes before making the final settings.

17.4.1 Basic Keypad Control (Factory Default, b000=0000 & b004=0000)

In its basic form as received from the factory, the inverter output is controlled from the keypad. Please refer to the **A** and **b** parameter list (Sec. 19.0) to view the factory default settings for the various parameters. When the inverter is powered up, the display will be flashing and momentarily show the inverter **input voltage**. The flashing display will then switch to a minimum output frequency of **05.00Hz**, the **FWD** LED will be flashing and the **Hz/RPM** LED will be *on*. By pressing the **STOP / RUN** key the output is active (**RUN**) and the display is on solid as is the **FWD** LED. Using the **< / RESET** key to select the digit **position** and the **UP/DOWN** keys to select the digit **value**, the output frequency may then be set from **00.0 to 50.0/60.0Hz** with minimum increments of **00.1Hz**. The **FWD/REV** key may be toggled to set the output direction. Both the output frequency and the output direction can be set when the inverter is in the **RUN or STOP** mode. When the **RUN/STOP** key is toggled to **STOP**, the set frequency is displayed and the display is again flashing. The **< / RESET** key also functions to initiate a **RESET after a Fault is cleared**.

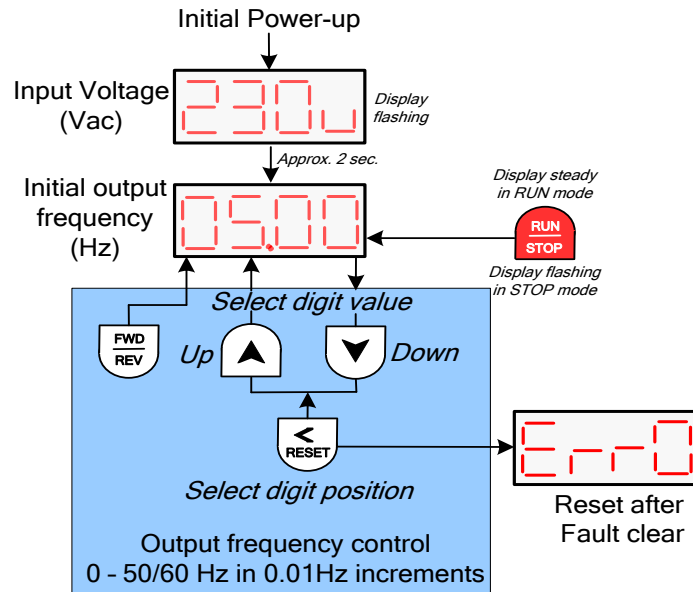





Fig. 17.2 Basic Keypad Control

17.4.2 Local / Remote Function



Local / Remote Function

In **Local** mode:

- The **RUN** command is controlled by the **RUN / STOP** key. 
- FREQUENCY** command
 - If b004 = 0000: The **UP/DOWN** keys control the output   frequency.
 - If b004 = 0001: The front panel potentiometer controls the output frequency.

In **Remote** mode:

- The **RUN** command is controlled via the function set by (**b000**)
- The frequency command is set by the function set by (**b004**)

To toggle between **Local / Remote** press the   keys **simultaneously**.

17.4.3 Setting Parameters b(Basic) and A(Advanced)

The accessing and setting of parameter groups **b** and **A** will be discussed next.

Important ! The **A (Advanced)** parameters are not directly accessible and must be enabled by setting parameter **b011=0001**.

Setting b (Basic) parameters

The basic parameters **b** can be accessed in two ways; the keypad or through the MODBUS protocol using an **optional** communications module. Here only keypad access will be described. Before proceeding, refer to the **b** and **A** parameter list (Sec. 19.0) and note that some parameters must be changed with the inverter in the **STOP** mode while others can be changed in either the **RUN** or **STOP** mode. Also changing certain parameters may also affect other functions and should be considered before making those changes.

To enter the **b** parameters, press the **DSP/ FUN** key; the display should show **b000**. Using the **> / RESET** key to select **the** digit position and the **Λ / V** keys to select the value, enter the parameter to be set and then press the **READ / ENTER** key to **save**; the display should momentarily flash **End** and return to the parameter selected.

Setting A (Advanced) parameters

As previously mentioned, the **A** parameters are not directly accessible and must be enabled. To do this, select parameter **b011** and then Code = **0001 (Enable)**. Press the **READ / ENTER** key to **save**; the display should be showing **b011**. Using the **> / RESET** key scroll to **b000** position and then press the **Λ** key; **A000** will be displayed. Using the same procedure in setting the **b** parameters scroll to the desired **A** parameter and select the **code** or **function** to be set and then press the **READ / ENTER** key to **save**. After all parameter changes have been made, press the **DSP/FUN** key to return the main display show the output frequency.

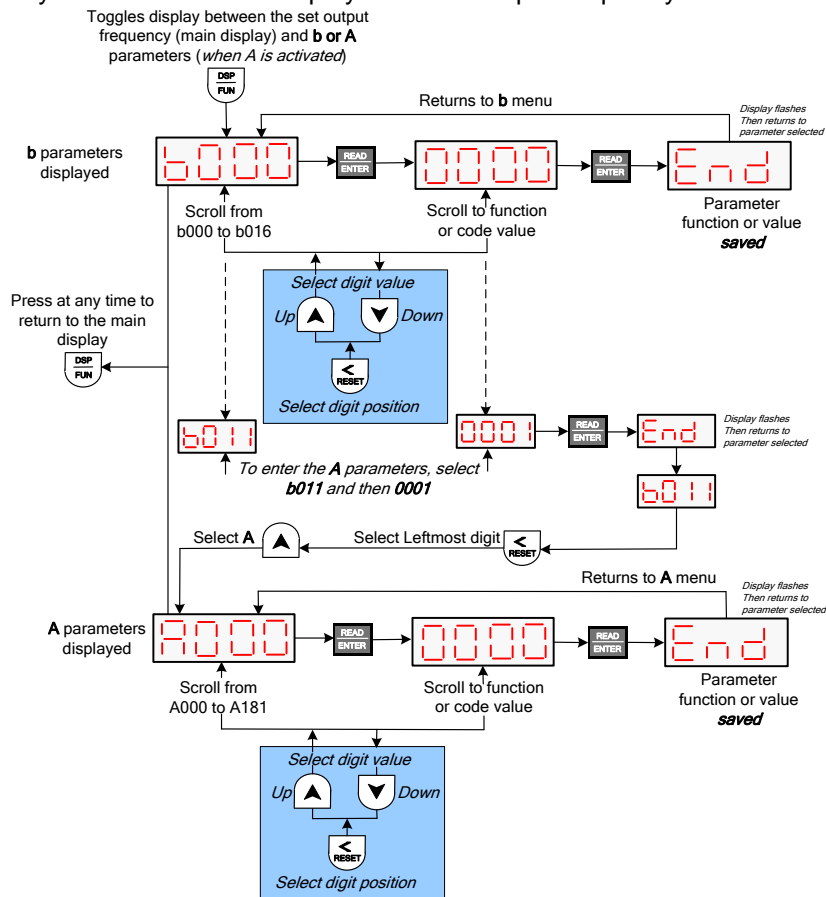

Fig. 17.3 Setting b (Basic) and A (Advanced) Parameters

18.0 Control Mode Selection

The VCM inverter series has three control modes:

1. General Vector Control.
2. VT (Variable torque) Vector Control (*Special for Fans and Pumps*).
3. V/f Control (*Factory default*).

The user can select one of these control modes by following the flow chart below and setting the parameters as shown. When vector control is selected the motor HP must match the inverter rating.

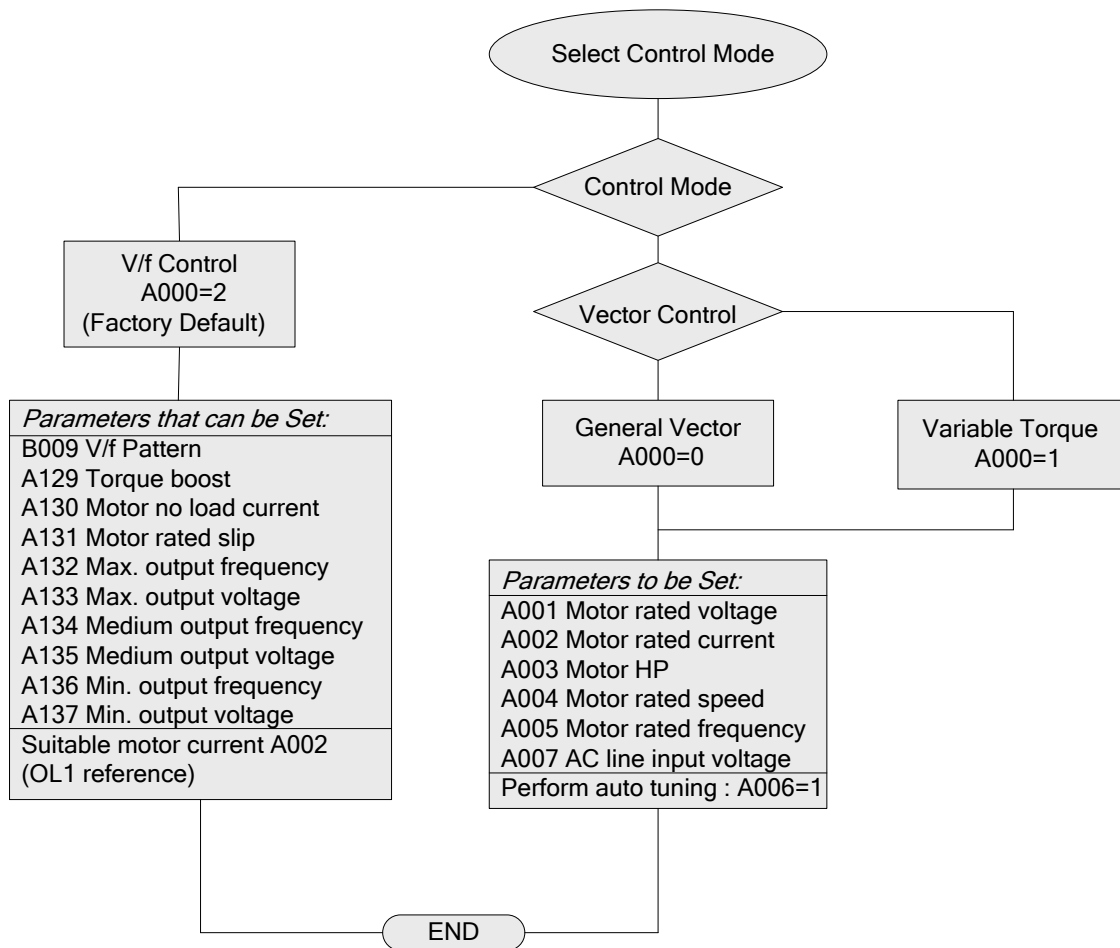

The V/f control mode should be used when the following conditions apply.

- (1) Using one inverter to drive several motors simultaneously.
 - In this case the rated inverter output current must equal or exceed the sum total of all of the motors connected.
 - The correct V/f pattern must be set by parameters A132 – A137.
- (2) The motors' nameplate information is unknown or the motor ratings are not standard.
 - In this case the inverter will set the motor characteristics in accordance with a standard MOTORTRONICS motor.
- (3) The specifications of the inverter and motor differ by more than 1 HP.

In V/f control, A001 - A005 max. & min. values are determined by the MOTORTRONICS standard motor specification limit. When parameter A000 = 2 (V/f control), the keypad will display 'Err2' if Auto tuning is performed.

19.0 b (Basic) and A (Advanced) parameters defined.

The VCM inverter has two programmable function parameter categories; **A** (Advanced) and **b** (Basic) which are described in detail in this section. It is important to note that while the parameters are set individually, they are interactive with other parameters and must be considered when adjusting the value. It would be prudent on the users' part to consider all parameters that are to be changed for a particular application before setting the individual values.

*Note that the Advanced parameters are designated with an uppercase **A**, where the Basic parameters are designated with a lowercase **b**. This is the result when a 7-segment LED display is used and is not intended to show priority.*

b (Basic)

These parameters consist of the more basic parameters that most users need to consider. Examples of basic settings are acceleration and deceleration rates (b007 and b008), run command and frequency sources (b000 and b004), and optional current and voltage displays (b013 - b015). One important **b** parameter, (b011) allows the user to select whether to allow access to **A** advanced parameters. As mentioned in the keypad navigation section, in order to access and change the **A** parameters, *b011 must be enabled.*

A (Advanced)

In general the **A** parameters allow the inverter to be tailored to specific applications in order to achieve more precise or specialized control. Examples are PID control, Auto-run mode, RS485 communication set-up, vector control mode etc. In addition, all analog and digital input and output configurations plus motor parameters are entered in the **A** parameters.

The tables below will summarize the **b** and **A** parameters, and then they will be individually discussed in detail.

Note: Some of the A parameters that are referenced in the Remarks column to note 9 are only available in Versions 1.3 or later. (See Appendix F)

19.1 b (Basic) Parameter Summary

Parameter No.	LCD Display	Description	Range/Code	Factory Setting	Remarks
b000	Run Source	Run Command Source Selection	0000: Keypad 0001: External Run/Stop Control 0002: Communication	0000	
b001	MFIT Run Mode	Run/Stop-Forward/Reverse Operation Mode with External Terminals	0000: Forward/Stop-Reverse/Stop 0001: Run/Stop-Forward/Reverse 0002: 3-Wire Control Mode-Run/Stop	0000	
b002	Reverse Oper	Reverse Prohibit operation	0000: Enable Reverse Command 0001: Disable Reverse Command	0000	
b003	Stopping Method	Stopping Method Selection	0000: Deceleration-to- Stop with DC Injection Braking (Rapid Stop) 0001: Coast to a Stop	0000	

Cont.

b004	Frequency Source	Frequency Command Source Selection	0000: Keypad 0001: Potentiometer on Keypad 0002: External Analog Signal Input or Remote Potentiometer 0003: Up/Down Frequency Control Using MFIT (S1 - S6) 0004: Communication setting frequency 0005: Pulse Follower	0000	
b005	Freq Upper Limit	Frequency Upper Limit (Hz)	0.01 - 400.00	50.00 / 60.00	2
b006	Freq Lower Limit	Frequency Lower Limit (Hz)	0.00 - 400.00	0.00	
b007	Accel Time 1	Acceleration Time # 1 (Seconds)	0.1 – 3600.0	10.0	1
b008	Decel Time 1	Deceleration Time # 1 (Seconds)	0.1 – 3600.0	10.0	1
b009	V/F Selection	Volts/Hz Patterns(Password protected)	0 - 18	9	2 & 3
b010	Password	Parameter Lock(except B010)	0000: Disable 0001: Enable	0000	
b011	Advanced Display	Advanced Display	0000: Disable 0001: Enable	0000	
b012	Select Language	Language Selection	0000: English 0001: German 0002: French 0003: Italian 0004: Spanish	0000	Only for LCD Keypad (option)
b013	Mtr Current	Motor Current Display Selection	0000: Disable Motor Current Display 0001: Enable Motor Current Display	0000	1
b014	Mtr Voltage	Motor Voltage Display Selection	0000: Disable Motor Voltage Display 0001: Enable Motor Voltage Display	0000	1
b015	Bus Voltage	DC Bus Voltage Display Selection	0000: Disable Bus Voltage Display 0001: Enable Bus Voltage Display	0000	1
b016	PID Fdbk(S6)Disp	PID Feedback Display Selection	0000: Disable PID Feedback Display 0001: Enable PID Feedback Display	0000	1

Notes:

1 - Can be modified during run.

2 - Related to factory settings in North America or overseas

3 - Only available in V/F mode

Cont.

19.2 b (Basic) Parameter Details

b000	Run Command Source Selection	0000: Keypad 0001: External terminal control 0002: Communication control
-------------	-------------------------------------	---

- 1.) b000 = 0000: The inverter is controlled by the keypad.
- 2.) b000 = 0001: The inverter is controlled by the external terminals. The Stop key will function as an emergency stop function. (Refer to parameter A010 description).
Note: For the safety of personnel and equipment, when b000 = 0001, please refer to parameter group A013, A014, A019 and A018 for a detailed description.
- 3.) b000 = 0002: The inverter is RS485 communication controlled.

b001	Operation modes for external terminals	0000: Forward/stop - reverse/stop 0001: Run/stop - forward/reverse 0002: 3-wire control mode - run/stop
-------------	---	--

- 1.) When operation command b000 = 0001 (external terminal), b001 is valid.
- 2.) When operation command b000 = 0001 (external terminal), the stop button is available for emergency stop. (Refer to A010 for detailed description).
- 3.) When both forward and reverse commands are ON, this will result in a stopped mode.

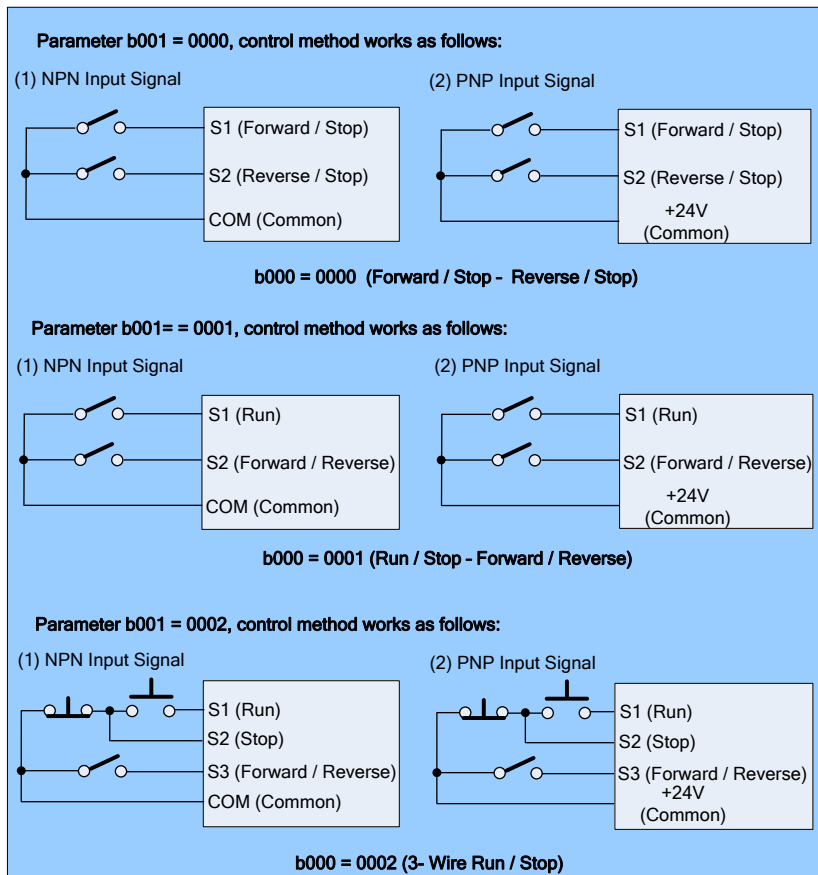

Fig. 19.1

Notes: 1 - In 3 wire control mode, terminal S1, S2 and S3 is not controlled by A050, A051 and A052.
 2- When b002 = 0001 reverse is prohibited. (See b002)

Cont.

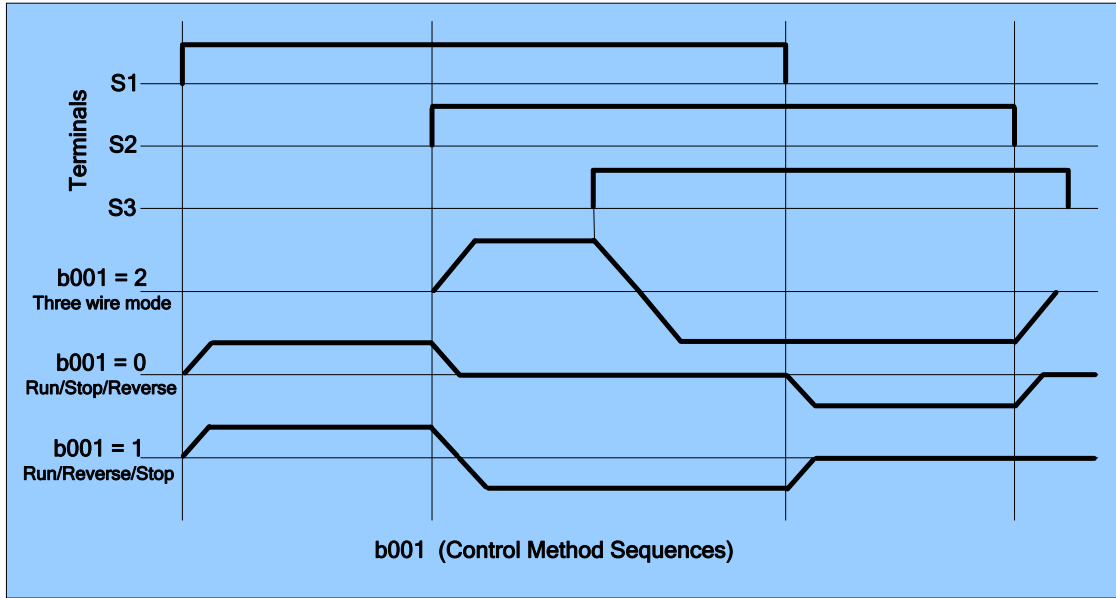

Fig. 19.2

b002	Disable Reverse Command	0000: Enable Reverse Command 0001: Disable Reverse Command
-------------	--------------------------------	---

b002 = 0001: The reverse command is invalid.

b003	Stopping Method	0000: Controlled Deceleration-to- Stop with DC injection Braking (Rapid Stop) 0001: Free run stop (Coast stop)
-------------	------------------------	---

- 1.) b003 = 0000: The inverter will decelerate to 0Hz within the configured deceleration time after receiving a stop command.
- 2.) b003 = 0001: The inverter will stop after receiving a stop command. The motor will coast to stop.

b004	Frequency Command Source Selection	0000: Keypad 0001: Potentiometer on Keypad 0002: External Analog Signal Input or Remote Potentiometer 0003: Up/Down Frequency Control Using MFIT (S1 - S6) 0004: RS485 Communication 0005: Pulse input (S5) setting frequency (Ver2.3)
-------------	---	---

- 1.) b004 = 0001: If one of the parameters in group A050 - A056 is set to 16 and the multifunction terminal is OFF, the frequency is set by the potentiometer on the keypad. When the multifunction terminal is ON, the frequency is set by the analog signal (auxiliary speed) on terminal block (TM2).
- 2.) b004 = 0002: If one of the parameters in group A050 - A056 is set to 16 and the multifunction terminal is OFF, the frequency is set by the analog signal on terminal block (TM2). When the input is ON, the frequency is set by the potentiometer on the keypad.
- 3.) Please refer to the description of parameter group A050 - A056 (multifunction input terminals) for the Up/Down terminal function.
- 4.) The priority in reading frequency is Jog, preset speed, ▲ ▼ on keypad, Up / Down or communication control.

Cont.

b005	Frequency Upper limit	0.01 - 400.00 (Hz)
b006	Frequency Lower limit	0.01 - 400.00 (Hz)

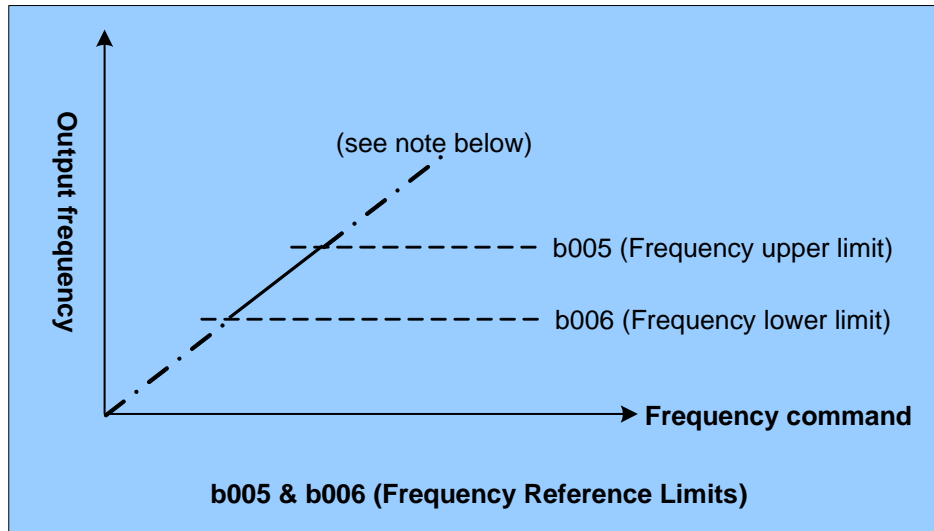

Fig. 19.3

Note: When b006 = 0 Hz and the frequency command is 0 Hz, the inverter will stop at 0 speed. When b006 > 0 Hz and the frequency command ≤ b006, the frequency output will be the b006 preset value.

b009 is the parameter for the V/f pattern selection (0 – 18) and will be covered extensively in the **A** (advanced) parameter section.

b010	Parameter Lock (except b010)	0000: Disable 0001: Enable
-------------	-------------------------------------	---------------------------------------

b010 = 0000: Disable parameter lock.

b010 = 0001: Enable parameter lock. *Note: Message “LOC” will be displayed if an attempt is made to program when enabled.*

b011	Advanced Display	0000: Disable 0001: Enable
-------------	-------------------------	---------------------------------------

b011 = 0000: Disable advanced display.

b011 = 0001: Enable access to advanced functions (A000 - A181).

b012	Language Selection	0000: English 0001: German 0002: French 0003: Italian 0004: Spanish
-------------	---------------------------	--

Note: The b012 function is only available for products with an LCD keypad (option). The function is not valid for the LED keypad.

b013	Motor Current Display Selection	0000: Disable Motor Current Display 0001: Enable Motor Current Display
-------------	--	---

b014	Motor Voltage Display Selection	0000: Disable Motor Voltage Display 0001: Enable Motor Voltage Display
-------------	--	---

Cont.

b015	DC Bus Voltage Display Selection	0000: Disable Bus Voltage Display 0001: Enable Bus Voltage Display
-------------	---	---

b016	PID Feedback Display	0000: Disabled 0001: Enable
-------------	-----------------------------	--

- 1.) The keypad displays the PID feedback value when:
 - A140=1(PID is enabled)
 - Parameter A049 = 20 (Terminal AI2 is PID analog feedback).
 - b016=1 (Displays AI2 as PID analog feedback *value 0 -100)
 - *If the feedback signal is 0 – 10V the display value = (AI2 / 10V) x100
 - *If the feedback signal is 0 – 20mA the display value =(AI2 / 20mA) x100
 - 2.) Press the DSP key to toggle between the output frequency and PID feedback value.
 - 3.) The inverter displays XXXF when in Run mode, and XXXr when stopped.
-

NOTES:

19.3 A (Advanced) Parameter Summary

Note: The **A** parameters that are referenced in the **Remarks** column to note 9 are only available in Versions **1.3** or later. (See Appendix F for further details)

Parameter No.	LCD Display	Description	Range/Code	Factory Setting	Remarks
A000	Control Mode	Control Mode	0000: Vector (General Purpose) 0001: Vector (Variable Torque) 0002: Volts/Hz	0002	
A001	Motor Rated Volt	Motor Rated Voltage (Vac)	Refer to Appendix B Table for default values		5
A002	Motor Rated Amps	Motor Rated Current (Amp)			5
A003	Motor Rated HP	Motor Rated Power (HP)			5
A004	Motor Rated RPM	Motor Rated Speed (RPM)			5
A005	Motor Rated Hz	Motor Rated Frequency (Hz)			5
A006	Auto Tuning	Motor Parameter Auto Tuning	0000: Disabled 0001: Enabled	0000	
A007	AC Input Volt	AC Line Input Voltage (Vac)	230V SERIES: 170.0 - 264.0 460V SERIES: 323.0 - 528.0		
A008 A009	Reserved	Reserved			
A010	Keypad Stop	Keypad Stop Button (In External Run/Stop Mode)	0000: Stop Button Enabled 0001: Stop Button Disabled	0000	
A011	Keypad Up/Down	Keypad Frequency Setting with Up/Down Keys in Run Mode	0000: 'Enter' must be pressed after frequency change with Up/Down Keys on keypad. 0001: Frequency will be changed directly when Up/Down Keys are pressed.	0000	
A012	Starting Method	Starting Method Selection	0000: Normal Start 0001: Enable Speed Search	0000	
A013	PwrL Selection	Momentary Power Loss and Restart	0000: Momentary power loss and restart disable 0001: Momentary power loss and restart enable 0002: Momentary power loss and restart enable while CPU is still powered up.	0000	
A014	PwrL Ridethru T	Momentary Power Loss Ride-Thru Time (Seconds)	0.0 - 2.0	0.5	
A015	Dir Start Sel	Direct Run After Power-Up	0000: Enable Direct run after power-up 0001: Disable Direct run after power-up	0001	
A016	Dir Start Delay	Delay-ON Timer (Seconds)	0.0 - 300.0	0.0	
A017	Auto Restart	Auto Restart Method	0000: Enable Speed Search 0001: Normal Start	0000	

Cont.

A018	Auto Restart Sel	Number of Auto Restart Attempts	0 - 10	0	
A019	Auto Restart Delay	Auto Restart Delay Time (Seconds)	0.0 - 800.0	0.0	
A020	Reset Mode Sel	Reset Mode Setting	0000: Enable Reset Only when Run Command is Off 0001: Enable Reset when Run Command is On or Off	0000	
A021 A022	Reserved	Reserved			
A023	S-Curve 1	S-Curve Acc/Dec #1 (Seconds)	0.0 - 4.0	0.2	
A024	S-Curve 2	S-Curve Acc/Dec #2 (Seconds)	0.0 - 4.0	0.2	
A025	Accel Time 2	Acceleration Time # 2 (MFIT)* (Seconds)	0.1 - 3600.0	10.0	1
A026	Decel Time 2	Deceleration Time # 2 (MFIT)* (Seconds)	0.1 - 3600.0	10.0	1
A027	Jog Acc Time	Jog Acceleration Time (MFIT)* (Seconds)	0.1 - 25.5	0.5	1
A028	Jog Dec Time	Jog Deceleration Time (MFIT)* (Seconds)	0.1 - 25.5	0.5	1
A029	DC Inj Freq	DC Injection Braking Start Frequency (Hz)	0.1 - 10.0	1.5	
A030	DC Inj Level	DC Injection Braking Level (%)	0.0 - 10.0% (Level 100% by based on Motor Rate Voltage A001)	5.0	
A031	DC Inj Time	DC Injection Braking Time (Seconds)	0.0 - 25.5	0.5	
A032	Skip Freq 1	Skip Frequency # 1 (Hz)	0.00 - 400.00	0.0	1
A033	Skip Freq 2	Skip Frequency # 2 (Hz)	0.00 - 400.00	0.0	1
A034	Skip Freq 3	Skip Frequency # 3 (Hz)	0.00 - 400.00	0.0	1
A035	Skip Bandwidth	Skip Frequency Bandwidth (\pm Hz)	0.00 - 30.00	0.0	1
A036 A037 A038	(Reserved)	Reserved			
A039	Parameter Lock	Parameter Lock	0000: Enable all Functions 0001: A059 - A068 cannot be changed 0002: All Functions Except A059 - A068 cannot be changed 0003: Disable All Functions	0000	

* MFIT refers to Multi-Function Terminal Inputs.

Cont.

A040	Parameter Copy	Copy Unit	0000: Disable 0001: Inverter to Copy Unit 0002: Copy Unit to Inverter 0003: Verify Copy Operation	0000	
A041	Fan Control	Fan Control	0000: Auto (Depend on drive temperature.) 0001: Operate while in RUN mode 0002: Always Running 0003: Always Stopped	0000	
A042	Energy Save Mode	Energy Saving Mode	0000: Disabled 0001: Controlled by MFIT [‡] at Set Frequency	0000	6
A043	Energy Save Gain	Energy Saving Gain (%)	0 - 100	80	6
A044	Carrier Freq	Carrier Frequency (kHz)	4 - 16	10	
A045	Display Units	Custom Units (Line Speed) Display Mode	0000: Drive Output Frequency is Displayed 0001: Line Speed is Displayed as an Integer (xxxx) 0002: Line Speed is Displayed with One Decimal Place (xxx.x) 0003: Line Speed is Displayed with Two Decimal Places (xx.xx) 0004: Line Speed is Displayed with Three Decimal Places (x.xxx)	0000	1
A046	Display Scaling	Custom Units (Line Speed) Value	0 - 9999	1800	1
A047 A048	(Reserved)				
A049	(AI2 Function)	AI2 Function Set	20 / 21 / 22	20	7

Cont.

NOTES:

A050	S1 Terminal Sel	Multifunction Input Term. S1	0000: Forward/Stop Command 0001: Reverse/Stop Command 0002: Frequency Command 2 (A062) 0003: Frequency Command 3 (A063) 0004: Frequency Command 4 (A065) 0005: Jog 0006: Acc/Dec # 2	0000	*7
A051	S2 Terminal Sel	Multifunction Input Term. S2	0007: Emergency Stop A Contact 0008: Base Block A Contact 0009: Speed Search 0010: Energy Saving 0011: Control Signal Selection 0012: Communication Selection	0001	
A052	S3 Terminal Sel	Multifunction Input Term. S3	0013: Acc/Dec Disabled 0014: Up Command 0015: Down Command 0016: Master/Auxiliary Speed 0017: PID Function Disabled	0002	
A053	S4 Terminal Sel	Multifunction Input Term. S4	0018: Reset 0019: Pulse Input terminal (terminal S5)	0003	
A054	S5 Terminal Sel	Multifunction Input Term. S5	0020: PID feedback signal AI2 (terminal *AI2) 0021: AI2 Bias signal 1 input (terminal *AI2)	0004	
A055	S6 Terminal Sel	Multifunction Input Term. S6	0022: AI2 Bias signal 2 input (terminal *AI2) 0023: Analog input (terminal AIN)	0018	
A056	AIN Term Sel	Multifunction Input Term. AIN	0024: Multi-Sequence Control *0025: Emergency Stop B Contact (NC) *0026: Base Block B Contact (NC)	0023	
A057	Term Scan Time	Multifunction Input Term. S1 - S6 Signal Verification Scan Time (mSec X 4)	1 – 100 (4-400msec)	5(20ms)	

Cont.

NOTES:

A058	Up/Dn Stop Mode	Stop Mode Using Up/Down	0000: When the terminals are Programmed for Up/Down Frequency Control, the Set Frequency will remain when the Drive stops. When the Drive stops, Up/Down Function Disabled. 0001: Up/Down is used. The preset frequency is reset to 0 Hz as the inverter stops. 0002: When the terminals are Programmed for Up/Down Frequency Control, the Set Frequency will remain when the Drive stops. When the Drive stops, Up/Down Function is Enabled.	0000	
A059	Jog Freq	Jog Frequency (Hz)	0.00 - 400.00	2.00	1
A060	Up/Down Step Fnc	Up/Down Step Function (Hz)	0.00 – 5.00	0.00	
A061	Freq command 1	Frequency Command 1 (Hz)	0.00 - 400.00	5.00	1
A062	Freq command 2	Frequency Command 2 (Hz)	0.00 - 400.00	5.00	1
A063	Freq command 3	Frequency Command 3 (Hz)	0.00 - 400.00	10.00	1
A064	Freq command 4	Frequency Command 4 (Hz)	0.00 - 400.00	20.00	1
A065	Freq command 5	Frequency Command 5 (Hz)	0.00 - 400.00	30.00	1
A066	Freq command 6	Frequency Command 6 (Hz)	0.00 - 400.00	40.00	1
A067	Freq command 7	Frequency Command 7 (Hz)	0.00 - 400.00	50.00	1
A068	Freq command 8	Frequency Command 8 (Hz)	0.00 - 400.00	60.00	
A069 A070	Reserved	Reserved			
A071	Auto_ Run Sel 1	Auto_ Run Mode Operation Selection 1	(0-3600 sec)	0000	
A072	Auto_ Run Sel 2	Auto_ Run Mode Operation Selection 2			
A073	Auto_ Run Sel 3	Auto_ Run Mode Operation Selection 3			
A074	Auto_ Run Sel 4	Auto_ Run Mode Operation Selection 4			
A075	Auto_ Run Sel 5	Auto_ Run Mode Operation Selection 5			

Cont.

A076	Auto_Run Sel 6	Auto_Run Mode Operation Selection 6	(0-3600 sec)	0000	
A077	Auto_Run Sel 7	Auto_Run Mode Operation Selection 7			
A078	Auto_Run Sel 8)	Auto_Run Mode Operation Selection 8			
A079 A080	(Reserved)	Reserved			
A081	Auto_Run Stop 1	Auto_Run Stop 1	0000: STOP 0001: Forward 0002: Reverse	0000	
A082	Auto_Run Stop 2	Auto_Run Stop 2			
A083	Auto_Run Stop 3	Auto_Run Stop 3			
A084	Auto_Run Stop 4	Auto_Run Stop 4			
A085	Auto_Run Stop 5	Auto_Run Stop 5			
A086	Auto_Run Stop 6	Auto_Run Stop 6			
A087	Auto_Run Stop 7	Auto_Run Stop 7			
A088	Auto_Run Stop 8	Auto_Run Stop 8			
A089 A090	(Reserved)	Reserved			
A091	Auto Run Invalid	Operation Mode Selection During Auto Run	0000: Auto Run mode not effective 0001: Auto Run mode for cycle. (continue running from the unfinished step if restarting) 0002: Auto Run mode performed periodically (continue running from the unfinished step if restarting) 0003: Auto Run mode for cycle, then hold the speed of final step to run. (continue running from the unfinished step if restarting) 0004: Auto Run mode for cycle. (starting a new cycle if restarting) 0005: Auto Run mode be performed periodically (starting a new cycle if restarting) 0006: Auto Run mode for one single cycle, then hold the speed of final step to run. (starting a New cycle if restarting)	0000	

Cont.

A092	AIN Gain	AIN Gain (%)	0 - 200	100	1
A093	AIN Offset	AIN Bias (%)	0 - 100	0	1
A094	AIN Bias	AIN Bias Selection	0000: Positive 0001: Negative	0000	1
A095	AIN Slope	AIN Slope	0000: Positive 0001: Negative	0000	1
A096	AIN Scan Time	AIN Signal Verification Scan Time (AIN, AI2) (mSec x 2)	1 - 100	50	
A097	AI2 Gain	AI2 Gain (%)*(AI2)	0 - 200	100	1 & *7
A098	Pulse Inp. Mult.	Encoder Impulse Ratio	0.001 - 9.999	1.000	
A099	Ref. Source2	Select the source of auxiliary frequency command	0 - 4	0	
A100 A102	Reserved	Reserved			
A103	AO Mode Sel	Analog Output Voltage Mode (0 - 10 VDC, Term. FM+)	0000: Output Run Frequency 0001: Input Frequency Setting 0002: Output Voltage 0003: DC Voltage 0004: Output Current 0005: PID Feedback	0000	1
A104	AO Gain	Analog Output Gain (%)	0 - 200	100	1
A105	Relay R1 Sel	Output Relay R1 Operation Mode	0000: Run 0001: Frequency Reached (Frequency Command) (Set Frequency \pm A108) 0002: Set Frequency (A107 \pm A108) 0003: Frequency Threshold Level (> A107) - Frequency Reached 0004: Frequency Threshold Level (< A107) - Frequency Reached 0005: Over torque Threshold Level 0006: Fault 0007: Auto Restart 0008: Momentary AC Power Loss 0009: Emergency Stop Mode 0010: Coast-to-Stop Mode 0011: Motor Overload Protection 0012: Drive Overload Protection 0013: PID Feedback Signal Loss 0014: Power on 0015: Under torque Threshold Level	0006	
A106	Relay R2 Sel	Output Relay R2 Operation Mode		0000	

Cont.

A107	Freq Agree	Frequency Reached (Hz) (Refer to A105: 0001)	0.00 - 400.00	0.00	1
A108	Freq Agree width	Frequency Reached Bandwidth (\pm Hz)	0.00 - 30.00	2.00	1
A109 A110	Reserved	Reserved			
A111	Trip Prevent – ACC	Trip Prevention Selection During Acceleration	0000: Enable Trip Prevention During Acceleration 0001: Disable Trip Prevention During Acceleration	0000	
A112	Trip ACC Level	Trip Prevention Level During Acceleration (%)	50 – 300 (Level 100% based on Motor HP setting A003)	200	
A113	Trip Prevent - DEC	Trip Prevention Selection During Deceleration	0000: Enable Trip Prevention During Deceleration 0001: Disable Trip Prevention During Deceleration	0000	
A114	Trip DEC Level	Trip Prevention Level During Deceleration (%)	50 – 300 (Level 100% based on Motor HP setting A003)	200	
A115	Trip Prevent - RUN	Trip Prevention Selection in Run Mode	0000: Enable Trip Prevention in Run Mode 0001: Disable Trip Prevention in Run Mode	0000	
A116	Trip Run Level	Trip Prevention Level In Run Mode (%)	50 - 300 (Level 100% based on Motor HP setting A003)	200	
A117	Dec Trip Time	Trip Prevention Deceleration Time Selection in Run Mode	0000: Trip Prevention Deceleration Time Set by B008 0001: Trip Prevention Deceleration Time Set by A118	0000	
A118	Dec Trip Time	Deceleration Time In Trip Prevention Mode (Seconds)	0.1 – 3600.0	3.0	
A119	Motor OL1 Sel	Electronic Motor Overload Protection Operation Mode	0000: Enable Electronic Motor Overload Protection 0001: Disable Electronic Motor Overload Protection	0000	
A120	Motor Type	Motor type Selection	0000: Electronic Motor Overload Protection Set for Non-Inverter Duty Motors 0001: Electronic Motor Overload Protection Set for Inverter Duty Motors	0000	
A121	Motor OL1 Curve	Motor Overload Protection Curve Selection	0000: Curve A (OL =103 %) (150 % for 1 Minute) 0001: Curve B (OL = 113 %) (123 % for 1 Minute)	0000	
A122	Motor OL1 Operat	Operation After Overload Protection is Activated	0000: Coast-to-Stop After Overload Protection is Activated 0001: Drive Will Not Trip when Overload Protection is Activated (OL1)	0000	

Cont.

A123	Torq Det Sel	Over/Under torque Detection Selection	0000: Disable Over/Under torque Operation 0001: Enable Over/Under torque Operation Only if at Set Frequency 0002: Enable Over/Under torque Operation while the Drive is in Run Mode	0000	
A124	Torq Det Res	Operation After Over/Under torque Detection is Activated	0000: Drive will Continue to Operate After Over-torque is Activated 0001: Coast-to-Stop After Over-Torque is Activated	0000	
A125	Torq Hi Level	Over-torque Threshold Level (%)	30 – 200 (Level 100% based by Motor HP A003)	150	
A126	Torq Hi Delay	Over-torque Activation Delay Time (Seconds)	0.0 - 25.0	0.1	
A127	Torq Lo Level	Under-torque Threshold Level (%)	30-200 (Level 100% based by Motor HP A003)	0	
A128	Torq Reserv Time	Under-torque Activation Delay Time (Seconds)	0.0 – 25.0	0.1	
A129	Torque Boost	Volts/Hz Curve Modification (Torque Boost) (%)	0 – 50.0	0.0	1 & 6
A130	Motor noLoad Amp	Motor No Load Current (Amps AC)	-----	0	5 & 6
A131	Motor rated Slip	Motor Slip Compensation (%)	0.0 – 100.0	0.0	1 & 6
A132	Max frequency	Maximum Frequency (Hz)	0.20 - 400.00	50.00/ 60.00	4 & 6
A133	Max Voltage	Maximum Frequency Voltage Ratio (%)	0.0 - 100.0 (100% based on AC Input Volt A007)	100.0	6
A134	Mid frequency	Mid Frequency (Hz)	0.10 - 400.00	25.00/ 30.00	4 & 6
A135	Mid Voltage	Mid Frequency Voltage Ratio (%)	0.0 - 100.0 (100% based on AC Input Volt A007)	50.0	6
A136	Min frequency	Minimum Frequency (Hz)	0.10 - 400.00	0.50/ 0.60	6
A137	Min Voltage	Minimum Frequency Voltage Ratio (%)	0.0 - 100.0 (100% based on AC Input Volt A007)	1.0	6
A138 A139	(Reserved)	Reserved			

Cont.

A140	PID Mode Sel	Mode Selection	0000: Disabled 0001: Bias D Control 0002: Feedback D Control 0003: Bias D Reversed Characteristics Control 0004: Feedback D Reversed Characteristics Control 0005: Frequency Command + Bias D Control 0006: Frequency Command + Feedback D Control 0007: Frequency Command + Bias D Reversed Characteristics Control 0008: Frequency Command + Feedback D Reversed Characteristics Control	0000	
A141	Feedback Gain	Feedback Gain	0.00 - 10.00	1.00	1
A142	PID Gain	Proportional Gain	0.0 - 10.0	1.0	1
A143	PID I Time	Integration Time (Seconds)	0.0 - 100.0	10.0	1
A144	PID D Time	Differentiation Time (Seconds)	0.00 - 10.00	0.00	1
A145	PID Offset	PID Offset	0000: Positive 0001: Negative	0000	1
A146	PID Offset Adj	PID Offset Adjust (%)	0 - 109	0	1
A147	Output Filter T	Output Lag Filter Time (Seconds)	0.0 - 2.5	0.0	1
A148	Fdbk Sel	Feedback Loss Detection Mode	0000: Disabled 0001: Enabled - Drive Continues to Operate After Feedback Loss 0002: Enabled - Drive "STOPS" After Feedback Loss	0000	
A149	Fdbk Lvl	Feedback Loss Detection Level (%)	0 - 100	0	
A150	Fdbk Loss Time	Feedback Loss Detection delay Time (Seconds)	0.0 - 25.5	1.0	
A151	PID I Limit	Integration Limit Value (%)	0 - 109	100	1
A152	I Time value Sel	Integration Value Resets to Zero when Feedback Signal equals the set point	0000: Disabled 0001:1 Second 0030:30 Seconds	0000	
A153	I Error Margin	Allowable integration Error Margin (Units) (1 Unit = 1/8192)	0 - 100	0	

Cont.

A154	AIN AI2 Source	AIN or AI2 Source signal	0000: AIN = 0 -10V or 0 - 20mA AI2 = 0 -10V or 0 - 20mA 0001: AIN = 0 -10V or 0 - 20mA AI2 = 2 -10V or 4 - 20 mA 0002: AIN = 2 -10V or 4 - 20 mA AI2 = 0 -10V or 0 - 20mA 0003: AIN = 2 -10V or 4 - 20 mA AI2 = 2 -10V or 4 - 20 mA	0000	7
A155	Sleep Level	Sleep Function Operation Level	0.00 - 400.00	0.0	
A156	Sleep Delay Time	Sleep Function Delay Time	0.0 - 25.5	0.0	
A157	Unit : NONE	Engineering Unit (only for PID Feedback used for LCD type)	0000 : NONE 0001 : FPM (feet per minute) 0002 : CFM (cubic feet per minute) 0003 : PSI (pounds per square inch) 0004 : GPH (gallons per hour) 0005 : GPM (gallons per minute) 0006 : in 0007 : ft 0008 : /s (units per second) 0009 : /m (units per minute) 0010 : /h (units per hour) 0011 : Deg F 0012 : inW (inches in water column) 0013 : HP 0014 : m/s (meters per second) 0015 : MPM (meters per minute) 0016 : CMM (cubic meters per minute) 0017 : W 0018 : kW 0019 : m 0020 : Deg C 0021 : % 0022 : rpm	0000	
A158	PID Fdbk Dsp Max	PID Feedback Display Unit Max	0-9999	1000	<i>Only for LCD keypad</i>
A159	PID Fdbk Dsp Min	PID Feedback Display Unit Min	0-9999	0	<i>Only for LCD keypad</i>
A160	Reserved	Reserved			
A161	Comm Error Operation Sel	Communications time-out operation selection	0000: Deceleration to stop. (b008: Deceleration time 1) 0001: Coast to stop. 0002: Deceleration to stop. (A026: Deceleration time 2) 0003: Continue operating.	0000	7
A162	Comm Error detection time.	Communications time-out detection time.	00.0 - 25.5 Sec.	00.00	7
A163	Se Comm Adr	Assigned Communication Station Number	1 - 254	1	2

Cont.

A164	Se Baud Rate	Baud Rate Setting (bps)	0000: 4800 0001: 9600 0002: 19200 0003: 38400	0003	2
A165	Comm Stop Bit	Stop Bit Selection	0000: 1 Stop Bit 0001: 2 Stop Bits	0000	2
A166	Comm Parity Sel	Parity Selection	0000: Without Parity 0001: With Even Parity 0002: With Odd Parity	0000	2
A167	Comm Data Format	Data Format Selection	0000: 8-Bits Data 0001: 7-Bits Data	0000	2
A168	Stator Resistor	Stator Resistance (Ohms)	Refer to Appendix B Table for default values		5
A169	Rotor Resistor	Rotor Resistance (Ohms)			5
A170	Equi Inductance	Equivalent Inductance (mH)			5
A171	Magnet Current	Magnetizing Current (Amps AC)			5
A172	Ferrite Loss	Ferrite Loss Conductance (gm)			5
A173 A174	Reserved	Reserved			
A175	Drive Model	Drive Horsepower Code	-----		3
A176	Software Version	Software Version	-----	-----	3
A177	Fault Log	Fault Jog (Last 3 Faults)	-----	-----	3
A178	Elapsed Hours	Accumulated Operation Time (Hours)	0 - 9999	-----	3
A179	Elapsed Hr*10000	Accumulated Operation Time (Hours X 10000)	0 - 27	-----	3
A180	Elapsed Time Sel	Accumulated Operation Time Mode	0000: Time Under Power 0001: Run Time	0000	
A181	Reset Parameter	Reset Drive to Factory Settings	1110: Reset for 50 Hz Motor Operation 1111: Reset for 60 Hz Motor Operation	0000	4

- Notes:
- 1 - Can be modified during run.
 - 2 - Cannot be modified while communication is active.
 - 3 - Value does not get set back to factory default after reset parameter enables. (See parameter A181)
 - 4 - Related to factory setting in North America or overseas.
 - 5 - The factory default value can be changed manually, or is changed automatically if required by auto-tuning.
 - 6 - Only available in V/F mode.
 - 7 - Valid only for Versions 1.3 and higher. (For further information see Appendix F)

19.4 A (Advanced) Parameter Details

A000	Control Mode	0000: Vector mode (General Mode) 0001: Vector mode (VT Mode) 0002: V/F mode
-------------	---------------------	--

Select the appropriate vector control mode or V/F mode in accordance with the load characteristics.

- 1.) Vector (general mode) is best suited to control general loads or rapidly-changed torque loads.
- 2.) Vector (VT mode) is suitable for Fan and Pump loads. The magnetizing current of the motor will vary with the torque, which will reduce the average current and save energy.
- 3.) If V/F mode is selected, set parameters, b009 and A129 - A137 in accordance with the load characteristics.

A001	Motor Rated Voltage(Vac)	Vac
A002	Motor Rated Current (A)	Amps
A003	Motor Rated Power (kW)	Killowatts
A004	Motor Rated Speed (RPM) (A004 X100 = Motor Rated Speed)	RPM
A005	Motor Rated Frequency (Hz)	Hz
A006	Motor Parameter Auto Tuning	0000: Disabled 0001: Enabled

- 1.) Whenever the vector mode is selected, the motor nameplate data must be input to parameters A001 – A005.
- 2.) The Auto tuning is performed by setting A006=0001. The detected internal data will automatically be written to parameters A168 to A172 when the display shows “End”.
Ex. If the motor rated speed is 1700 rpm, set A004 to 17.0

 Caution
<ol style="list-style-type: none"> 1. The motor parameter auto tuning is stationary auto tuning. During motor auto tuning, the motor does not rotate, and the keypad displays “-AT-”. 2. During motor parameter auto tuning, the input signal in the control circuit is invalid. 3. Before motor parameter auto tuning, confirm that the motor is stopped. 4. The motor parameter auto tuning is only available for vector control modes (A000 = 0000 or A000 = 0001).

A007	AC Line Input Voltage (Volts)	230V Series : 170.0 - 264.0 Vac 460V Series : 323.0 - 528.0 Vac
-------------	--------------------------------------	--

To accurately represent the voltage level of the inverter, input the actual measured line voltage.

A010	Keypad Stop Button	0000: Stop Button Enable 0001: Stop Button Disable
-------------	---------------------------	---

When A010 = 0000, the STOP key is available on the keypad to activate a stop regardless of the drive Run source as per parameter b000.

A011	Keypad Operation with Up/Down Keys in Run Mode	0000: ‘Enter’ must be pressed after frequency changes with the Up/Down Keys on keypad to save selection. 0001: Frequency will be changed directly when Up/Down Keys are Pressed
-------------	---	--

A012	Starting Method Selection	0000: Normal Start 0001: Enable Speed Search
-------------	----------------------------------	---

- 1.) A012 = 0000: At start, the inverter accelerates from 0 to the target frequency in the set time.
- 2.) A012 = 0001: At start, the inverter accelerates to the target the frequency from the detected speed of the motor.

A013	Momentary Power Loss and Restart	0000: Momentary Power Loss and Restart Disable 0001: Momentary Power Loss and Restart is Enabled 0002: Momentary Power Loss and Restart Enable while CPU is Operating.
A014	Momentary Power Loss Ride-Thru Time(seconds)	0.0 - 2.0 sec.

- 1.) If the input voltage drops below the under voltage threshold level, the motor inverter will coast to stop. If the input voltage recovers within the A014 preset time, the motor will spin start from the trip frequency, or the inverter will trip with 'LV-C' being displayed.
- 2.) The allowable power loss time differs with ratings of the various models. The range is from 1 to 2 seconds.
- 3.) A013 = 0000: If power is lost, the inverter will not start.
- 4.) A013 = 0001: If the power loss time is less than the value of A014 the inverter will Spin Start in 0.5 second when the power is re-supplied, and the number of restart times is unlimited.
- 5.) A013 = 0002: if the power is lost but is reapplied *before* the inverter loses control power, the inverter will restart according to the settings of b000, and A017 and the status of the external switch.

Note: If b000=0001, A017=0000 and A013=0001 or 0002 and power is lost for an extended time, disconnect the power to the drive to avoid injury to personnel and equipment when power is re-applied.

A015	Direct run after power up	0000: Enable Direct Run After Power Up 0001: Disable Direct Run After Power Up
-------------	----------------------------------	---

! Danger

- 1.) A015 = 0000: If the inverter is set to external terminal control (b000 = 0001), the inverter will auto-start if the run switch is ON when power is applied. It is recommended that the run switch be turned to OFF to avoid injury to personnel or equipment when power is applied.
- 2.) A015 = 0001: If the inverter is set external terminal control (b000 = 0001), the inverter will not auto-start if the run switch is ON when power is applied and the display will flash 'STP1'. In this case it is necessary to disconnect power and turn the run switch OFF and then restart.

A016	Delay-ON Timer (seconds)	0 - 300.0 sec.
-------------	---------------------------------	-----------------------

On power up with A015 = 0000, the inverter will perform auto restart after the delay time selected by A016.

A017	Auto restart method	0000: Enable Speed Search 0001: Normal Start
-------------	----------------------------	---

- 1.) A017 = 0000: The inverter will detect motor speed and accelerate to the set frequency.
- 2.) A017 = 0001: The inverter will accelerate from stop (zero speed) to set frequency.

A018	Number of Auto restart Attempts	0 - 10 times
A019	Auto restart Delay Time (seconds)	0 - 800.0 sec.

- 1.) A018 = 0: The inverter will not auto restart after fault trip.

Cont.

- 2.) A018>0 and A019 = 0: The inverter will conduct a spin start 0.5 seconds after fault trip. The motor will run to the frequency at the trip point and then to set frequency at the selected acceleration and deceleration times.
- 3.) A018>0 and A019>0: the output will be stopped for a period which is determined by parameter A019 after a trip fault. Then, the inverter will spin start to the preset frequency.
- 4.) If the inverter is set to braking mode, it will not perform a restart after a trip fault.

A020	Error reset mode setting	0000: Enable Reset Only when Run Command is Off 0001: Enable Reset when Run Command is On or Off
-------------	---------------------------------	---

A020 = 0000: If the inverter trips on a fault turn the Run switch OFF to perform a reset, or restarting will not occur unless power is cycled.

b007	Acceleration Time #1 (seconds)	0.1 – 3600.0 sec.
b008	Deceleration Time #1 (seconds)	0.1 – 3600.0 sec.
A023	S Curve of First Acceleration Stage (seconds)	0.0 – 4.0 sec.
A024	S Curve of Second Acceleration Stage (seconds)	0.0 – 4.0 sec.
A025	Acceleration Time #2 (seconds)	0.1 – 3600.0 sec.
A026	Deceleration Time #2 (seconds)	0.1 – 3600.0 sec. for Emergency Stop reference
A027	Jog Acceleration Time(seconds)	0.1 – 25.5 sec.
A028	Jog Deceleration Time (seconds)	0.1 – 25.5 sec.

- 1.) Formula for calculating acceleration and deceleration time: The denominator is based on the rated frequency of the motor (A005).

$$\text{Acceleration time} = b007 \text{ (or A025)} \times \frac{\text{Preset frequency}}{A005} \quad \text{Deceleration time} = b008 \text{ (or A026)} \times \frac{\text{Preset frequency}}{A005}$$

- 2.) When A050 – A056 = 0006 (the second acceleration and deceleration time), the first acceleration / deceleration / S curve or the second acceleration / deceleration / S curve will be set by the external input terminal.
- 3.) When A050 – A056 = 0005 (Jog), Jog run is controlled by external terminals. The acceleration and deceleration action will be at Jog acceleration and deceleration times.
- 4.) When the external terminals select A050 – A056 to = 0005 (Jog) and 0006 (acceleration and deceleration time the resulting control of the accelerating and decelerating times are prioritized as follows.

Function	Acc/ Dec time 1 (b007 / b008)	Acc/ Dec time 2 (A025 / A026)	JOG Acc/Dec time (A027 / A028)
Preset value	b004 determines the output frequency source	b004 determines the output frequency source	A059 determines the Jog frequency
A050 - A056 = 0005 Jog command	Off	Off	On
A050 - A056 = 0006 Acc/Dec time 2	Off	On	Off

- 5.) When the S curve time (A023 / A024) is set to 0 sec., the acceleration and deceleration ramps are linear.
- 6.) When S curve time (A023 / A024) is greater than 0 sec., the acceleration and deceleration action is as shown in Fig.19.4.).
- 7.) Regardless of the stall prevention period, the actual acceleration and deceleration time = preset acceleration / deceleration time + S curve time. For example: acceleration time = b008 + A023.

Cont.

8.) During the acceleration and deceleration process, there may be a residual error in Acceleration and deceleration toggling. If you need to toggle the acceleration and deceleration time during the acceleration / deceleration process, set the S curve time (A023 / A024) = 0 sec.

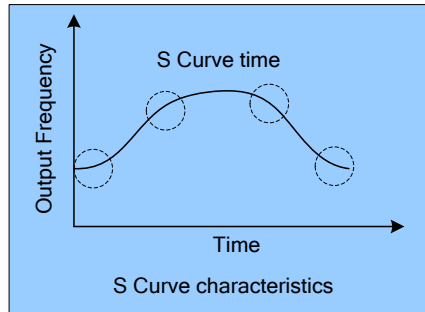

Fig. 19.4

A029	DC Injection Brake Start Frequency (Hz)	0.1 – 10.0 Hz
A030	DC Injection Brake Level (%)	0.0 – 10.0 %
A031	DC Injection Brake Time (seconds)	0.0 – 25.5 sec.

A031 and A029 is the active time and start frequency respectively of DC braking as shown below.

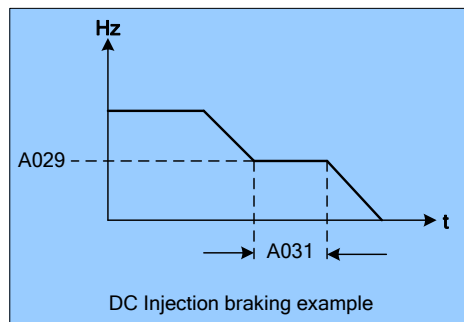

Fig. 19.5

A032	Skip Frequency #1 (Hz)	0.00 – 400.00 Hz
A033	Skip Frequency #2 (Hz)	
A034	Skip Frequency #3 (Hz)	
A035	Skip Frequency Bandwidth (± Hz)	0.00 – 30.00 ± Hz

Example: A032 = 10.0Hz, A033 = 20.0 Hz, A034 = 30.0 Hz and A035 to 2.0Hz

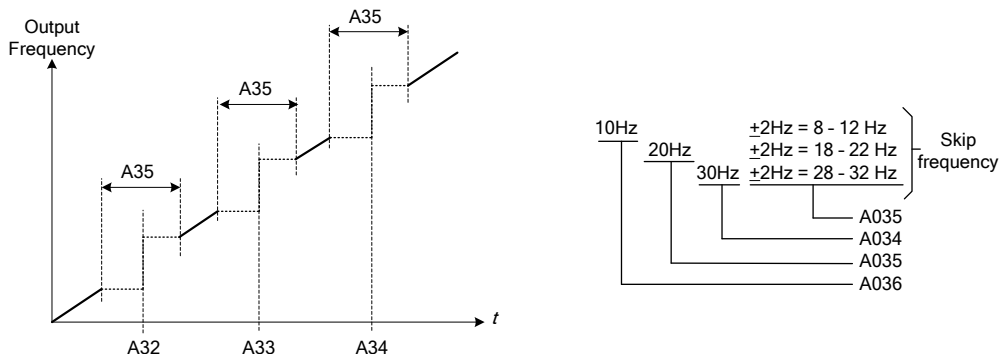

Fig. 19.6

039	Parameter lock function	0000: Enable all Functions 0001: A059 - A068 cannot be changed 0002: All Functions Except A059 - A068 cannot be changed 0003: Disable All Functions
------------	--------------------------------	--

A040	Parameter Copy	0000: Disable 0001: Inverter to Copy Unit 0002: Copy Unit to Inverter 0003: Verify
-------------	-----------------------	---

- 1.) A040 = 0000: The Inverter copy operation is not in the copy mode.
- 2.) A040 = 0001: Copy the inverter parameters to keypad module.
- 3.) A040 = 0002: Copy the keypad module parameters to inverter.
- 4.) A040 = 0003: Compares the parameters in the inverter to the parameters in the keypad module.

Note: If there is a mismatch, error message “EPr2” will be displayed.

Note: The copy function is only available for the models with same ratings.

A041	Fan Run Control	0000: Auto (Depends on temperature) 0001: Operate while in RUN Mode 0002: Always Running 0003: Always Stopped
-------------	------------------------	--

- 1.) A041 = 0000: The fan runs when the inverter temperature rises above a set level.
- 2.) A041 = 0001: The fan runs while the inverter is running.
- 3.) A041 = 0002: The fan is continuously running regardless of the status of the inverter.
- 4.) A041 = 0003: The fan is always stopped regardless of the status of the inverter.

Note: The function is disabled at and above 15HP for the 230V class and above 20HP for the 460V class, for these models, the fan will run continuously after power up.

A042	Energy Saving Mode Operation (Note a.)	0000: Disabled 0001: Controlled by MFIT at Set Frequency
A043	Energy Saving Operation Gain (%)	0 – 100 % (Note b.)

- 1.) With fans, pumps or other high inertia loads, starting torques are typically high. When set speed is reached the torque demand becomes less, consequently the output voltage can be lowered to save energy by setting parameter A042 = 00001.
- 2.) Setting A050 - A056 = 10 (Multifunction input terminal) enables energy saving.
- 3.) If the multifunction terminal is set to =10 (energy saving control terminal), and A042 = 0001, the output voltage will gradually decline to the original voltage x A043 (0-100%) when the terminal is ON. When the terminal is OFF the output voltage will rise to original voltage.

Note: a. Energy saving mode is only available in the V/F mode. (A000 = 0002)

b. The declining and rising speeds of voltage for energy saving are the same as those for Speed Search.

A044	Carrier Frequency (KHz)	2 – 16 KHz
-------------	--------------------------------	-------------------

A044	Carrier Frequency	A044	Carrier Frequency	A044	Carrier Frequency	A044	Carrier Frequency
2	2KHz	6	6KHz	10	10KHz	14	14KHz
3	3KHz	7	7KHz	11	11KHz	15	15KHz
4	4KHz	8	8KHz	12	12KHz	16	16KHz
5	5KHz	9	9KHz	13	13KHz		

Note: Increasing the carrier frequency will generally result in lower audible noise from the motor. However, increased carrier frequencies can potentially cause electrical interference on other equipment operating in proximity to the VCM inverter.

A045	Custom Units (Line Speed) Display Mode	0000: Drive Output Frequency is Displayed 0001: Line Speed is Displayed as an Integer (xxxx) 0002: Line Speed is Displayed with One Decimal Place (xxx.x) 0003: Line Speed is Displayed with Two Decimal Places (xx.xx) 0004: Line Speed is Displayed with Three Decimal Places (x.xxx)
A046	Custom Units (Line Speed) Value	0 – 9999

- 1.) The preset frequency is displayed when the inverter is stopped when the operation line speed is displayed when the inverter is running.
- 2.) The maximum preset line value of A046 is equal to the rated frequency of the motor (A005). For example, if the maximum line speed is set at 1800 RPM, the line speed is equal to 900 RPM when output is 30Hz with a motor base frequency of 60Hz.

A049	AI2 Function: Analog Input	0020: PID Feedback Signal AI2 (Terminal AI2) 0021: AI2 Bias Signal 1 Input (Terminal AI2) 0022: AI2 Bias Signal 2 Input (Terminal AI2)
-------------	-----------------------------------	---

Note: Parameter 049 is only available in Versions 1.3 or later. Please refer to pages 52 and 55 for details on parameter selections

NOTES:

A050 to A056	Multifunction input terminals (TM2 S1-S6/AIN/ *AI2)	0000: Forward/Stop Command 0001: Reverse/Stop Command 0002: Frequency Command 2 (A062) 0003: Frequency Command 3 (A063) 0004: Frequency Command 4 (A064) 0005: Jog 0006: Acc/Dec time # 2 0007: Emergency Stop Contact A 0008: Base Block Contact A 0009: Speed Search Stop 0010: Energy Saving 0011: Control Signal Selection 0012: Communication Control Signal Selection 0013: Acc/Dec Disabled 0014: Up Command 0015: Down Command 0016: Master/Auxiliary Speed 0017: PID Function Disabled 0018: Reset 0019: Pulse Input Terminal (Terminal S5) 0020: PID Feedback Signal AI2 (Terminal *AI2) 0021: AI2 Bias Signal 1 Input (Terminal *AI2) 0022: AI2 Bias Signal 2 Input (Terminal *AI2) 0023: Analog Input (Terminal AIN) 0024: Multi-Sequence Control *0025: Emergency Stop Contact B *0026: Base Block Contact B
	<i>Note: The functions 0019 to 0024 are assigned to the specific parameters shown.</i>	<i>A054</i> <i>A049</i> <i>A049</i> <i>A049</i> <i>A056</i> <i>A050</i>

**Note: only available in Versions 1.3 or later (See Appendix F for further details).*

Digital inputs S1 to S6 and analog input AIN on terminal block (TM2) are multifunction input terminals.

A050 - A056 Function Description: Any function may be assigned to parameters A050 – A056 with the exception of functions 0019, 0020, 0021, 0022, 0023 and 0024 which are assigned to specific parameters as shown above.

1. **0000:** (Forward / Stop Command). If forward command is ON, the inverter runs in the forward direction, and stops when the command is OFF. The A050 factory default is forward.
- 0001:** (Reverse / Stop Command) If reverse command is ON, the inverter runs in the reverse direction, and stops when the command is OFF. The A051 factory default is reverse.
2. **0002, 0003, 0004:** (Frequency Command 2/3/4 at A062/A063/A065). When External multifunction input terminals are ON, the inverter operates at the preset speed, for the time that the input is ON. The corresponding frequency output vs. the terminal input states is shown in the table on the next page.
3. **0005:** (Jog). When Jog operation is selected, the inverter operates at the Jog acceleration and deceleration times. The corresponding jog frequency parameter is shown in the table on the next page. The priority of frequency is: Jog Speed→Preset Speed→Keypad frequency or external frequency signal.

Cont.

Multifunction terminal 3 Preset value=04	Multifunction terminal 2 Preset value =03	Multifunction terminal 1 Preset value =02	Jog Command terminal Preset value =05	Output frequency preset value
0	0	0	0	A061
X	X	X	1	A059
0	0	1	0	A062
0	1	0	0	A063
0	1	1	0	A064
1	0	0	0	A065
1	0	1	0	A066
1	1	0	0	A067
1	1	1	0	A068

1 = ON, 0 = OFF, & X = Don't Care

4. **0006:** (Toggle acceleration and deceleration time). This input selects the acceleration 1 / deceleration 1 / S curve 1 or acceleration 2 / deceleration 2 / S curve 2.
5. **0007 or 0025:** (External Emergency Stop Contact A or B). When the external emergency stop contact is closed, the inverter will decelerate to stop via the time set by A026 (Deceleration time 2) and the display will flash E.S when the emergency stop signal is received regardless of the b003 (Stopping method) setting. To restart the drive after the external emergency stop contact is opened, press the run key on the keypad or toggle the run input contact. The inverter will restart from the start frequency. If the emergency signal is cleared before the inverter stops completely, the inverter still carries out the emergency stop. The multifunction output relays, A105 (Relay output 1) and/or A106 (Relay output 2), will activate with an emergency stop if A105 and/or /A106 = 9: (Rapid stop mode). Contact A is normally open, and activates emergency stop when energized. Contact B is normally closed and emergency stop activates when de-energized.
6. **0008 or 0026:** (Base Block Contact A or B) The inverter output voltage immediately goes to 0, and the motor does a coast stop. Contact A is normally open and base block activates when energized. Contact B is normally closed and base block activates when de-energized.
7. **0009:** (Speed Search Start) When starting, the inverter detects the present speed of the motor, then accelerates from that speed to preset speed.
8. **0010:** (Energy-saving operation) With Fans, Pumps, or other high inertial loads, starting torques are typically higher while at set speed, the torque demand is less. Consequently the output voltage is reduced to save energy. When the input is ON the output voltage will gradually decline as set speed is reached. When OFF, the output voltage will gradually increase to the original voltage.
- Note: The acceleration and deceleration rate during the energy saving operation is the same as that of Speed Search.*
9. **0011:** (Control signal selection)
 OFF: The setting of b000 (Run source) and b001 (MFIT) determines the operating mode.
 ON: The keypad controls the operating mode.
- Note: The toggling of 0011 is allowed while the drive is running, however when doing this, please use caution around the operating equipment.*
10. **0012:** (Communication signal selection)
 OFF: RS485 communication, from a PC or PLC can control the inverter operation and allow modification to the parameters. The keypad and external control terminals TM2 are not functional in this mode. Furthermore, the keypad can only display the voltage, current and frequency and the parameters are read - only. The Emergency stop is still valid.

Cont.

ON: The inverter is controlled by the keypad regardless of the settings of b000 (Run source) and b004 (Frequency source). The RS485 communication can still read and write the inverter parameters.

11. **0013:** (Disable acceleration and deceleration) When ON, acceleration and deceleration is disabled until the input is turned OFF. The function is illustrated below.

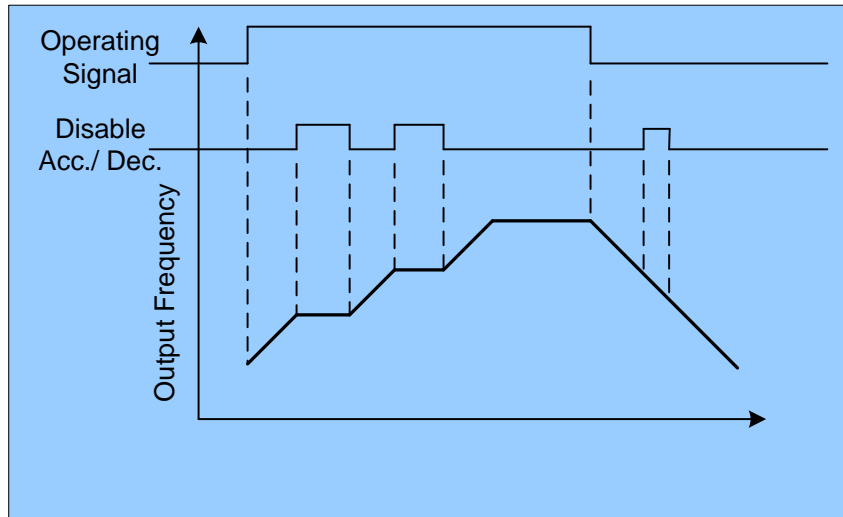

Fig. 19.7

12. **0014** and **0015:** (Up / Down Function)

Actual Acc /Dec time is based on the following settings:

- (1) To use the Up / Down function set b004 = 3. The other frequency signals are not valid.
- (2) When A058 = 0000 and A060 = 0000, the inverter accelerates to the preset value of A061, and then maintains a constant speed. When the inverter receives either the Up or Down command, it will accelerate or decelerate until the command is released. The inverter runs at the speed setting at the time of release. When the inverter receives a stop command, the inverter will either ramp or free - run to stop as determined by the setting of b003. The frequency at the stop time will be stored in A061. The Up / Down key is invalid when the inverter is stopped. The preset parameters are modified through the keypad.
- (3) When A058 = 0001, the inverter will operate from 0Hz when the Run command is ON. The Up / Down and stop command action is the same as above. The next operation will start at 0 Hz.
- (4) The Up /Down signals are invalid if pressed simultaneously.
- (5) When a Run command is given, the inverter will accelerate to the preset frequency set by A061 and maintain that speed. If the step frequency A060 is set to a given value ($\neq 0$), and the Up or Down terminal is turned ON for less than 2 seconds, the set frequency will accelerate or decelerate to a new value equal to $A061 \pm A060$ which will become the new set frequency. Each time the Up or Down terminal is turned ON for less than 2 seconds the set frequency will change by the value of A060 (See fig. on next page). If the Up / Down signal is maintained over 2 seconds, or if A060 = 0, the frequency will continuously accelerate or decelerate toward the frequency limits until the signal is released.

The Up / Down functional range is subject to the set frequency upper and lower frequency limits, b005 and b006.

Cont.

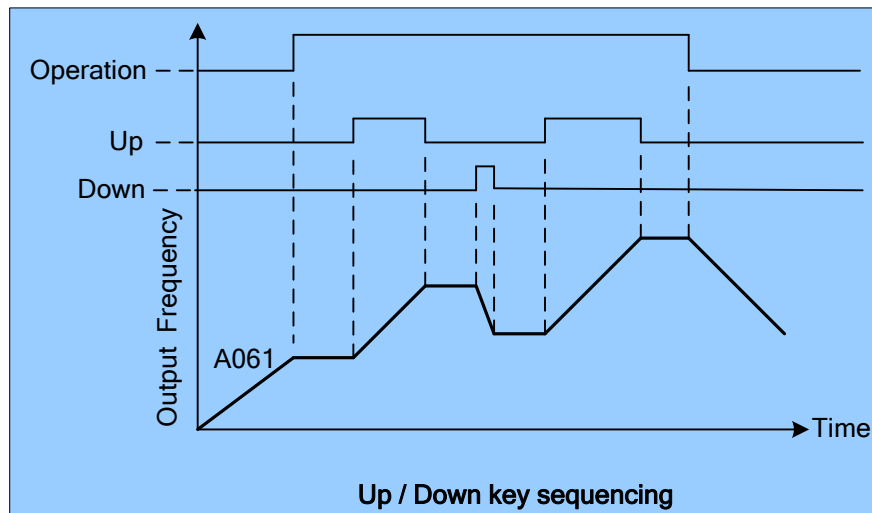
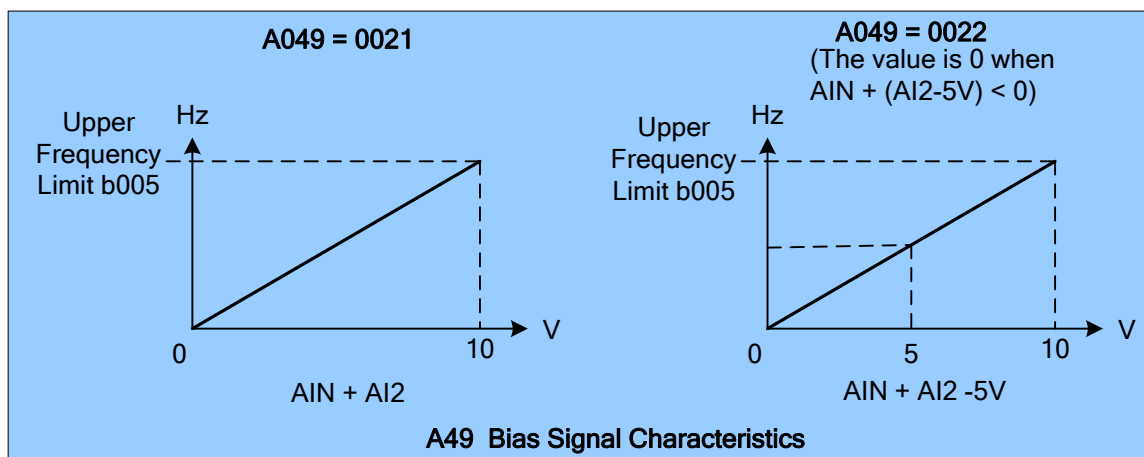

Fig. 19.8

13. **0016:** (Main / Auxiliary speed toggle)
 OFF: The frequency is set by the potentiometer (Master Speed) on the keypad.
 ON: The frequency is set by the AUX. input signal terminal (Auxiliary Speed) on TM2.
14. **0017:** (PID Function Disable) When the PID Function Disable is ON, the PID function, A140 is disabled.
15. **0018:** (Reset Command) The Reset command performs the same function as the Reset Key on the keypad. When the command is OFF, the inverter does not respond. The factory default of A055 is the Reset command.
16. **0024:** (Multi-Sequence Control) The Multi-Sequence control is set to 0024 to become the input terminal for the Auto – Run mode.
17. **A054 = 0019:** (Pulse Input Terminal) The multifunction terminal S5 when A054 is set to 0019 and becomes the input terminal for encoder signals.
18. **A049 = 0020:** (PID Feedback Input Terminal) The multifunctional terminal AI2 becomes the PID feedback input terminal and can be set to 0 – 10V (0 – 20 mA) or 2 – 10V (4 – 20 mA) set by parameter 140.
 = **0021:** (Bias Signal 1) and = **0022:** (Bias Signal 2) The Bias signals provide a means of setting an offset for the Keypad potentiometer or AIN analog input. Only 0-10V (0-20mA) or 2-10V (4-20mA) is available.



Note: Parameter A049 is only available in Versions 1.3 or later (See Appendix F for further details).

Fig. 19.9

Cont.

- 19. **A056 = 0023:** (Analog input AIN) The multifunction analog terminal AIN = 0023, controlling the output frequency.
- 20. **A050 = 0024:** (Multi-Sequence Control) The Multi-Sequence control is set to 0024 to become the input terminal for the Auto – Run mode.

A057	Multifunction terminals S1 - S6 and AIN signal scan times (4mSec)	1 - 100 times
-------------	--	----------------------

- 1.) This function is used to minimize the electrical noise on the digital and analog inputs by sampling the input signal every 4 mSec. x 1-100 (4 to 400 mSec. user selected). If the signal value is the same for the interval time selected it is treated as a valid value. If the signal changes during the interval time it is treated as noise.
- 2.) The minimum scan period is 4mS while the maximum is 400mS.
- 3.) The user can set the scan time interval depending on the noise environment. In general, the noise can be minimized by increasing scan time interval, however the response to valid signal changes will be slower.

Note: If input AIN is digital, an input voltage level above 8V is treated as ON, and below 2V as OFF.

A058	Stop Mode Using Up/Down	<p>0000: When Up/Down is used, the preset frequency is maintained when the inverter stops, and the UP/Down is unavailable.</p> <p>0001: When Up/Down is used, the preset frequency is reset to 0 Hz when the Inverter stops.</p> <p>0002: When Up/Down is used, the preset frequency is Maintained when the inverter stops, and the UP/Down is available.</p>
-------------	--------------------------------	--

- 1.) A058 = 0000: Upon receiving a Run command the inverter will accelerate to the speed set in parameter 6-00. When the Up / Down command is activated the inverter begins to accelerate / decelerate and the inverter will hold that speed when the Up / Down command removed. When a Stop command is given, the inverter will ramp stop or stop as determined by the b003. It will store the frequency value at the time when the Stop signal is activated. The Up / Down function is unavailable when the inverter is stopped. The keypad is available to modify the preset frequency (6-00). If A058 = 0002, the UP/Down function is available When the inverter stops.
- 2.) A058 = 0001: When the Run terminal is energized, the inverter accelerates from 0 Hz, and the Up / Down function is same as above. When a Stop command is given, the inverter will ramp stop or stop (determined by b003) to 0 Hz. The next Run command will start from 0 Hz.

A059 & A061 – A068	Jog and Preset (MFIT) Speed Setting on Keypad	Set Jog and preset speed by Keypad
-------------------------------	--	---

- 1.) A050 – 056 = 0002 - 0004 (preset speed 1 - 3)
ON: the inverter operates at preset speeds 1 – 8 based on the corresponding frequency output vs. the terminal input states is shown in the table.
- 2.) A050 – 056 = 0005 (Jog)
ON: the inverter operates in Jog acceleration time / Jog decelerate time / ON

Cont.

Function Code No.	LCD Display	Description	Range/Code	Factory Setting
A059	(Jog Freq)	Jog Frequency (Hz)	0.00 - 400.00	2.00
A061	(Freq Command 1)	Frequency Command 1 (Hz)	0.00 - 400.00	5.00
A062	(Freq Command 2)	Frequency Command 2 (Hz)	0.00 - 400.00	5.00
A063	(Freq Command 3)	Frequency Command 3 (Hz)	0.00 - 400.00	10.00
A064	(Freq Command 4)	Frequency Command 4 (Hz)	0.00 - 400.00	20.00
A065	(Freq Command 5)	Frequency Command 5 (Hz)	0.00 - 400.00	30.00
A066	(Freq Command 6)	Frequency Command 6 (Hz)	0.00 - 400.00	40.00
A067	(Freq Command 7)	Frequency Command 7 (Hz)	0.00 - 400.00	50.00
A068	(Freq Command 8)	Frequency Command 8 (Hz)	0.00 - 400.00	60.00

Priority in reading the frequency: Jog > Preset speed > Keypad frequency or external frequency signal

Multifunction terminal 3 Preset value=04	Multifunction terminal 2 Preset value=03	Multifunction terminal 1 Preset value=02	Jog Command terminal Preset value=05	Output frequency preset value
0	0	0	0	A061
x	x	x	1	A059
0	0	1	0	A062
0	1	0	0	A063
0	1	1	0	A064
1	0	0	0	A065
1	0	1	0	A066
1	1	0	0	A067
1	1	1	0	A068

A060	Step of Up/Down Function (Hz)	0.00 – 5.00 Hz
-------------	--------------------------------------	-----------------------

- 1.) A060 = 0.00: When the Up terminal is ON, the frequency continuously increases while the Down terminal is ON, the frequency continuously decreases until the upper and lower frequency limits are reached.
(See fig. below)

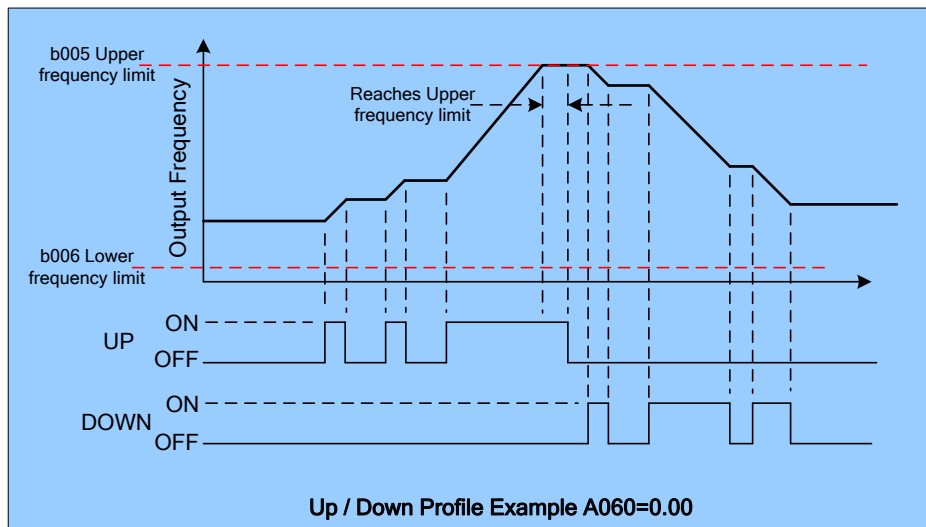

Fig. 19.10

Cont.

2.) A060 = 0.01 to 5.00: When the Up / Down terminal is ON, the output frequency *steps* at the incremental frequency set by A060. If Up / Down signal is ON for more than 2 seconds, the output frequency will ramp continuously toward the frequency limits until it is turned OFF. (See fig. below)

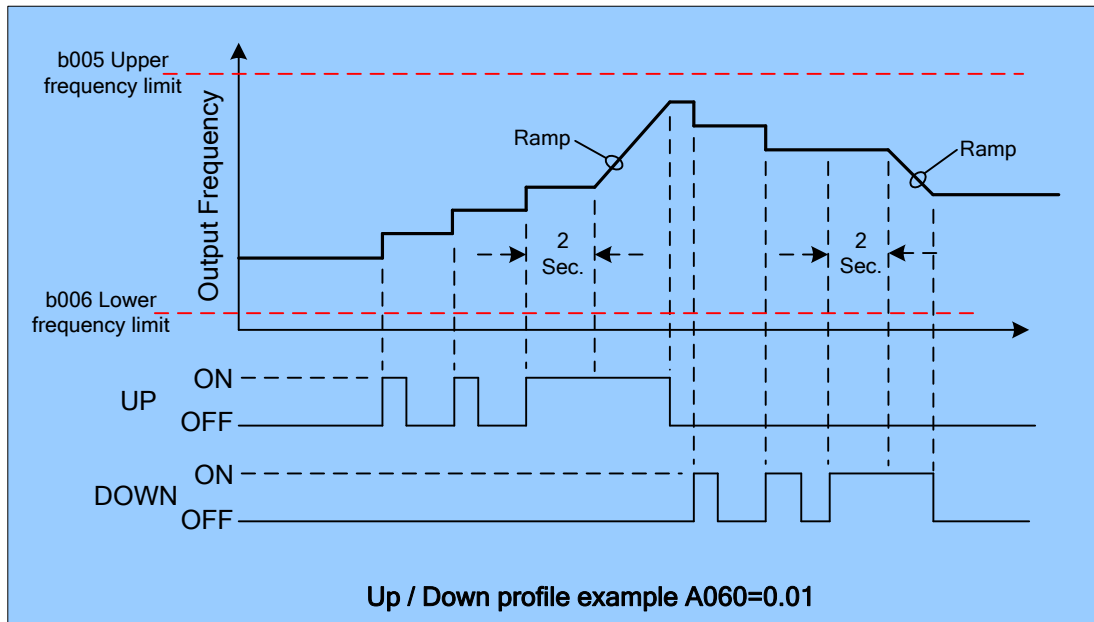

Fig. 19.11

A061	Auto_Run Mode Frequency Command	1	0 – 400 Hz
A062		2	
A063		3	
A064		4	
A065		5	
A066		6	
A067		7	
A068		8	

A071	Auto_Run Mode Operation Selection	1	0 –3600 Sec.
A072		2	
A073		3	
A074		4	
A075		5	
A076		6	
A077		7	
A078		8	

Cont

A081	Auto_Run Stop	1	0000: Stop 0001: Forward 0002: Reverse
A082		2	
A083		3	
A084		4	
A085		5	
A086		6	
A087		7	
A088		8	

A091	Operation Mode Selection During Auto Run	0000: Auto Run Mode Not Effective 0001: Auto Run mode for one cycle. (continue running from the unfinished step if restarting) 0002: Auto Run mode is performed periodically (continue running from the unfinished step if restarting) 0003: Auto Run mode for one cycle, then hold the speed of final step to run. (continue running from the unfinished step if restarting) 0004: Auto Run mode for one cycle. (starting a new cycle if restarting) 0005: Auto Run mode is performed periodically (starting a new cycle if restarting) 0006: Auto Run mode for one single cycle, then hold the speed of final step to run. (starting a new cycle if restarting)
-------------	---	--

- 1.) A091 = 0000 – 0006: Selects the mode of operation in Auto_Run.
- 2.) In the Auto_Run mode:
 - A061 - A068: Selects the run frequency
 - A071 - A078: Selects the time of the run frequency
 - A081 - A088: Selects the direction (Fwd / Rev) of the output or the Stop mode.
- 3.) In the Auto_Run mode the acceleration / deceleration follow the settings of b007 / b008.
- 4.) In the auto_Run mode, the multi-step frequency commands 02 - 04 are ineffective.
- 5.) Some examples of the Auto_Run mode are as follows:

(A) Single Cycle Running - (A091= 0001and 0004)

In this example, the inverter will run for a single full cycle based upon the specified settings in the table and then stop.

Cmd / Sel	Freq Cmd. Hz	Oper Sel. Sec.	Fwd / Rev / Stop
1	A061 = 15	A071 = 20	A081 = Fwd.
2	A062 = 30	A072 = 25	A082 = Fwd.
3	A063 = 50	A073 = 30	A083 = Fwd.
4	A064 = 20	A074 = 40	A084 = Rev.
5 - 8	A065 – A068 = 0	A075 – A078 = 0	A085 – A088 = 0

Cont.

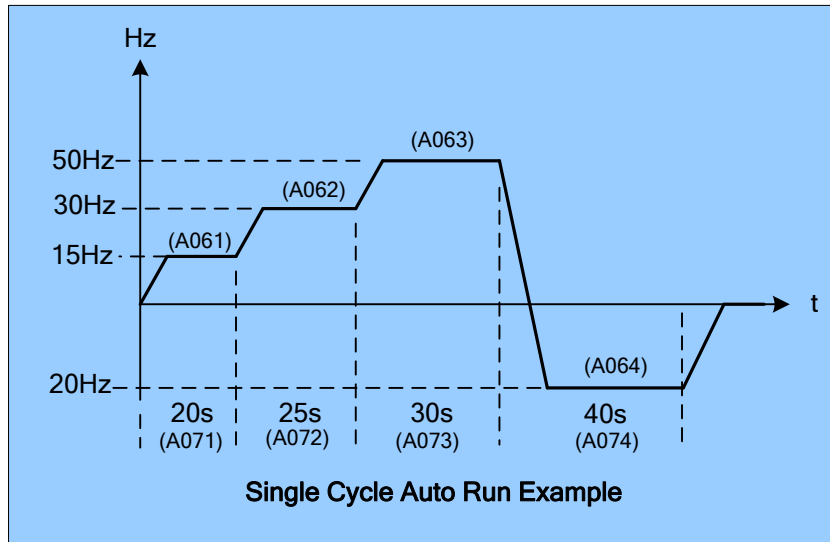

Fig. 19.12

(B) Periodic Running - (A091 = 0002 and 0005)

In this example the inverter will repeat the same cycle periodically.

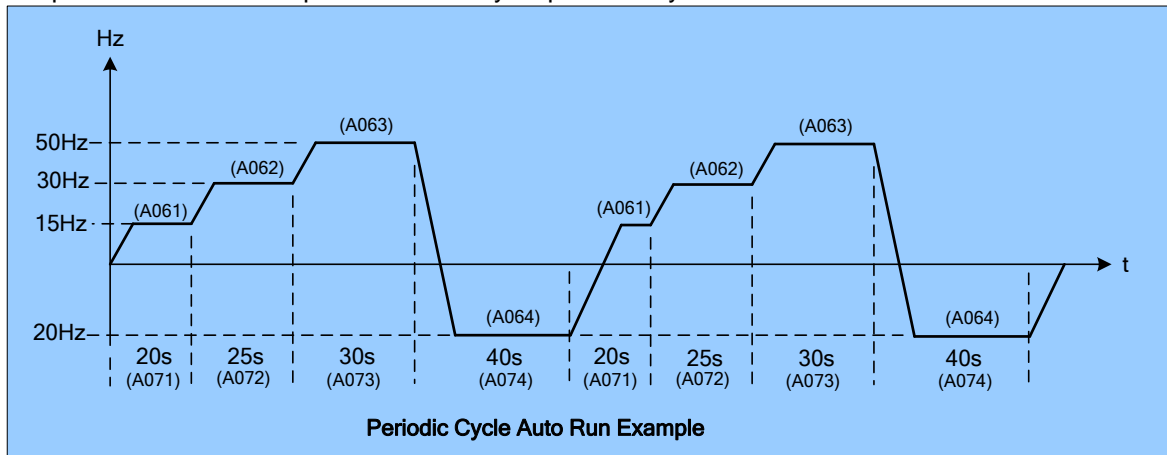

Fig. 19.13

(C) Single Cycle (A091 = 0003 and 0006)

In this example the speed of final the step will be held to run.

The settings are the same as the 2 prior examples except A084 which is changed to =1 (Fwd).

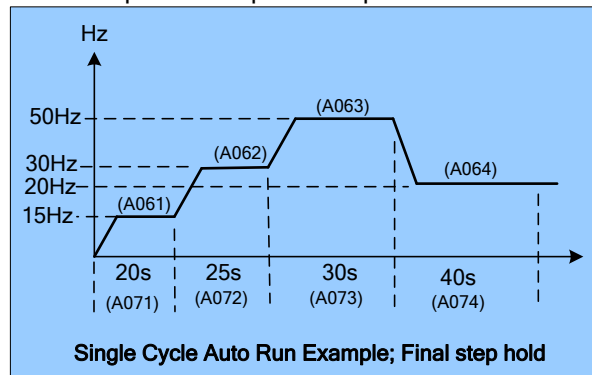

Fig. 19.14

Cont.

- (D) A091 = 0001 - 0003: If the inverter stops and re-starts, it will continue running from the unfinished step, according to the setting of A091.
 = 0004 - 0006: If the inverter stops and re-starts, it will begin a new cycle and continue running according to the setting of A091.

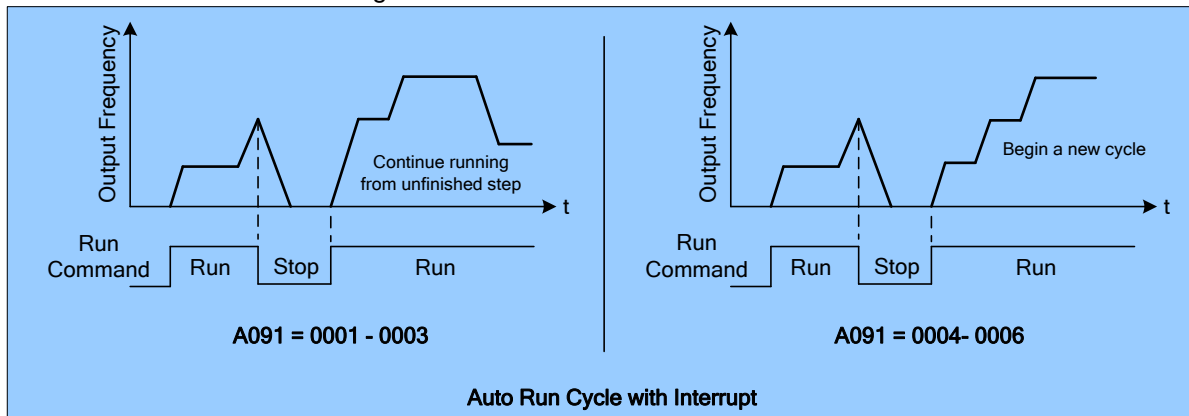

Fig. 19.15

A092	AIN Gain (%)	0 - 200
A093	AIN Bias (%)	0 - 100
A094	AIN Bias Selection	0000: positive 0001: negative
A095	AIN Slope	0000: positive 0001: negative
A096	AIN & AI2 signal verification Scan Time	1 - 100 x (4 mSec.)
A097	AI2 Gain (%)	0 - 200

- 1.) A094 = 0000: (AIN Bias selection positive) 0V (0mA) corresponds to the lower frequency limit, and 10V (20mA) corresponds to the upper frequency limit.
- 2.) A094 = 0001: (AIN Bias selection negative) 10V (20mA) corresponds to the lower frequency limit, and 0V (0mA) corresponds to the upper frequency limit.
- 3.) AI2 / S6 (PID feedback signal)

When A154 = 0000 (0 – 10 V / 0 – 20mA):

$$\text{Output frequency (SW2 set to I)} = I \times (b005) / 20; \text{ when } I \geq 0$$

$$\text{Output frequency (SW2 set to V)} = V \times (b005) / 10; \text{ when } V \geq 0$$

When A154 = 0001 (2 – 10 V / 4 – 20 mA):

$$\text{Output frequency (SW2 set to I)} = (I-4) \times (b005)/16; \text{ when } I \geq 4 \text{ (Output frequency =0; when } I < 4)$$

$$\text{Output frequency (SW2=V)} = (V-2) \times (b005)/8; \text{ when } V \geq 2 \text{ (Output frequency =0; when } V < 2)$$

Cont.

NOTE: Refer to the example tables and figures below for additional information

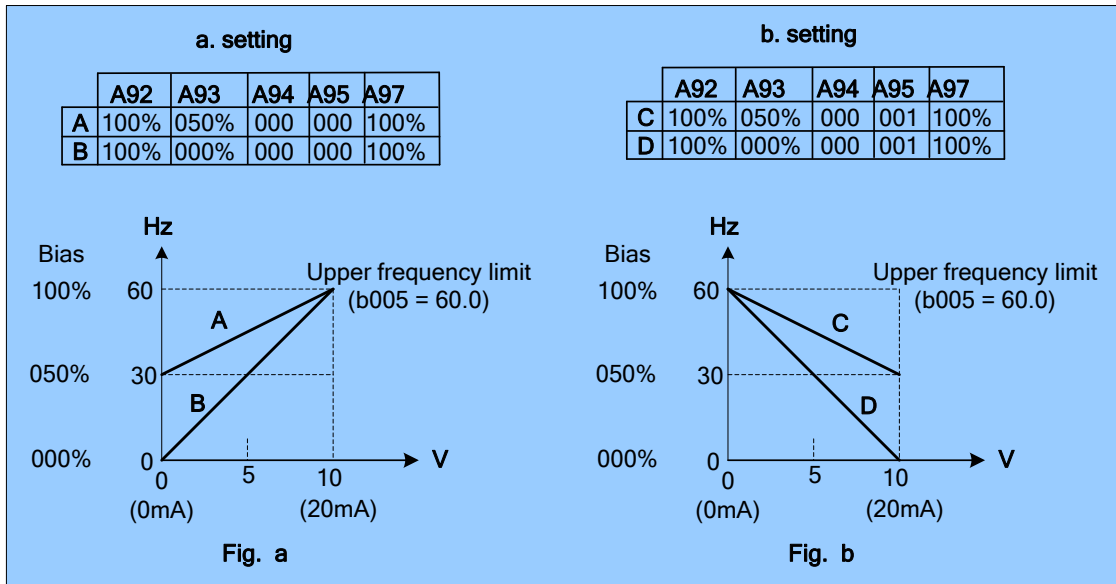

Fig. 19.16

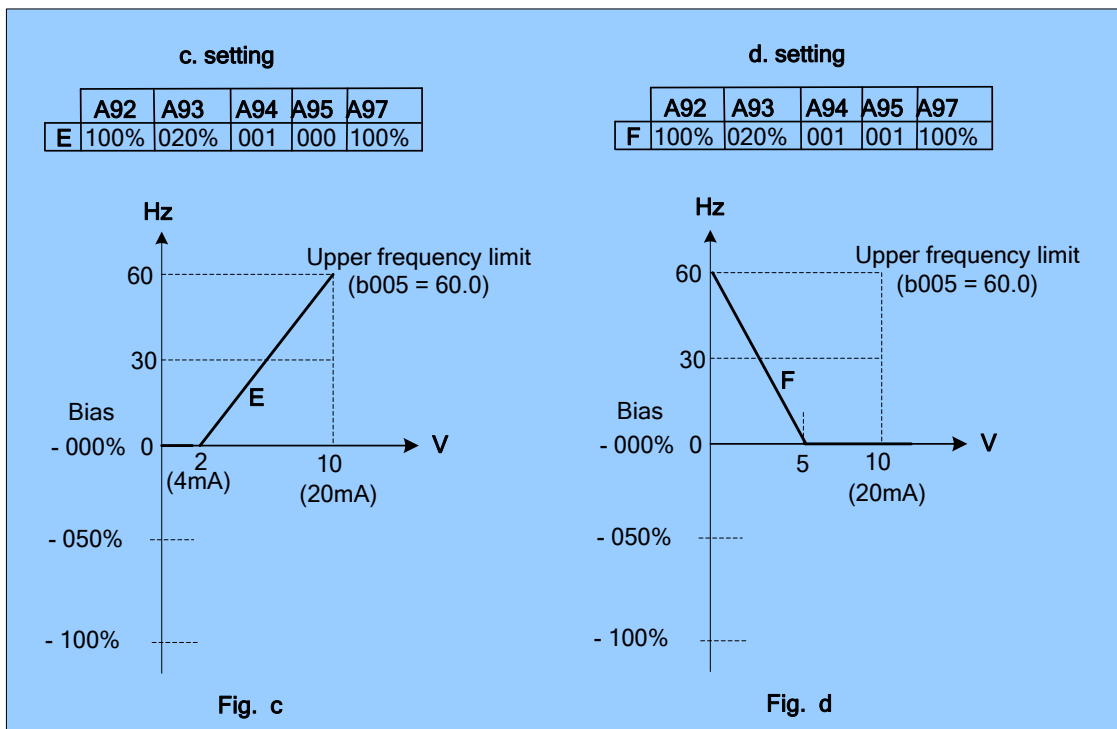

Fig. 19.17

4.)The inverter reads the average value of the A/D signals once per (A096x4ms). Set the scan intervals to minimize the environmental noise by increasing the value of A096. However, increasing the scan time will result in a *decreased* the response time.

098	Pulse input frequency ratio	0.001 – 9.999
------------	------------------------------------	----------------------

When the frequency source parameter b004 is = 0005 (pulse follower), the actual command frequency will be determined by the pulse input signal frequency and parameter A098. The inverter command frequency = (input pulse frequency) x A098 (times ratio)

Example: when the input pulse frequency is = 1KHz (1000), and A098 is set at 1.50, the inverter frequency command is $1000 \times 1.5 = 1500 / 100 = 15.00\text{HZ}$. The frequency accuracy of S5 is by base of 100, 1K (1000) present 10.00 HZ.

A099	Select the source of auxiliary frequency command	0: 061 (frequency command 1) 1: VR speed control on keypad 2: AIN analog input on TM2 3: UP/Down input on TM2 4: Serial communication
-------------	---	--

When frequency source command is set as b004 = 0005 (pulse input), and if A050 – A056 (multi-functional input terminals) is set to = 16 (Master / Auxiliary Speed), when the input is *off*, the command frequency is the pulse input. When the terminal is *on* the frequency command source is controlled by the setting of A099.

A103	Analog Output Voltage Mode	0000: Output frequency 0001: Frequency Setting 0002: Output voltage 0003: DC Voltage 0004: Output current 0005: PID Feedback
A104	Analog Output Gain	0 – 200%

- 1.) The multifunction analog output range is 0 -10VDC. The selected output units is determined by A103 (Analog output voltage mode); (see following table and fig.). A104 (Analog output gain) is used to calibrate the output signal for use with an external voltmeter or other peripheral equipment.
- 2.) The analog output of the PID Feedback value (the input voltage or current to AI2) is output to terminal FM+. (set by parameter b016). The output value corresponds to the PID feedback input signal 0 -10V (0 - 20 mA) or 2 -10V (4 - 20mA).

A103 Setting	A	B	Comments
0000	f	b005 (f max.)	FM+ 0 – 10 V corresponds to output frequency
0001			FM+ 0 – 10 V corresponds to set frequency
0002	V	Vector A001 or V/f A107 x A133	1. When A000 = 0 or 1 (vector), FM+ 0 – 10 V corresponds to 0 – motor rated voltage. 2. When A000 = 2 (V/f), FM+ 0 – 10 V corresponds to 0 – AC line input voltage (A007) x max. output frequency voltage ratio % (A133).
0003	V	500 V or 1000V	200 V class: FM+ 0 – 10 V corresponds to 0 – 500 VDC 400 V class: FM+ 0 – 10 V corresponds to 0 – 1000 VDC
0004	I	Rated current	FM+ 0 – 10 V corresponds to rated current. Ex. The rated current of 201 is 4.5 A. FM+ 0 -10 V corresponds to 0 – 4.5 A.
0005	%	100 % feedback value	1. When A140 ≠ 0 , FM+ 0 – 10 V corresponds to 0 – 100% feedback value. 2. When A140 = 0 , FM+ 0 – 10 V corresponds to 0 – 10V or 0 – 20mA on terminal S6/AI2.

Cont.

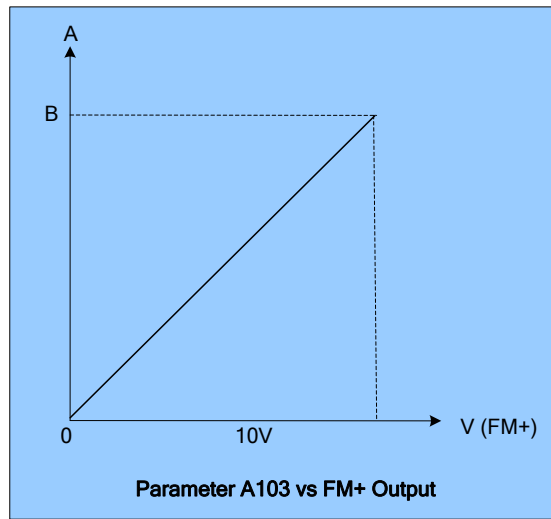

Fig. 19.18

A105	Relay 1 (R1C,R1B,R1A terminals on TM2)	0000: Run 0001: Frequency Reached (Target Frequency) (Frequency Reference \pm A108) 0002: Set Frequency (A107 \pm A108) 0003: Frequency Threshold Level (> A107) – Frequency Reached 0004: Frequency Threshold Level (< A107) – Frequency Reached 0005: Over-torque Threshold Level 0006: Fault
A106	Relay 2 (R2C,R2A terminals on TM2)	0007: Auto-restart 0008: Momentary AC Power Loss 0009: Emergency Stop Mode 0010: Coast-to-Stop Mode 0011: Motor Overload Protection 0012: Drive Overload Protection 0013: PID Feedback Signal Break 0014: Power On 0015: Under-torque Threshold Level
A107	Output Frequency Detection Level	0 –400 Hz
A108	Frequency Reached Bandwidth	0 –30 Hz

Cont.

The following Fig.'s show some examples of the functions of output relays R1 (A105) and R2 A106)

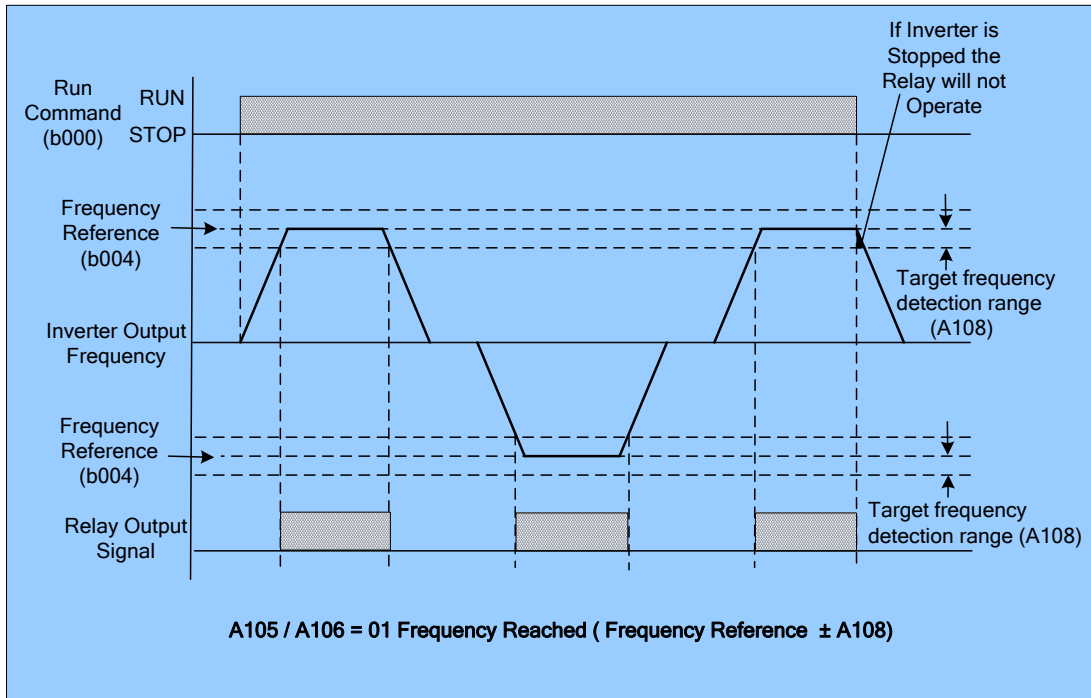

Fig. 19.19

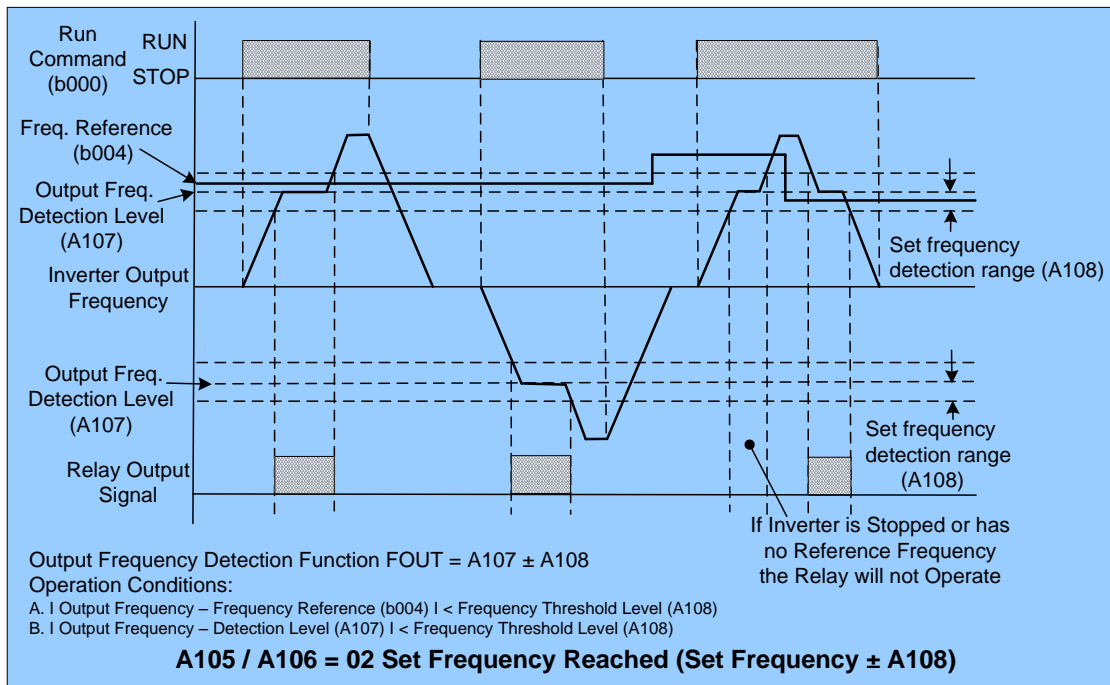

Fig. 19.20

Cont.

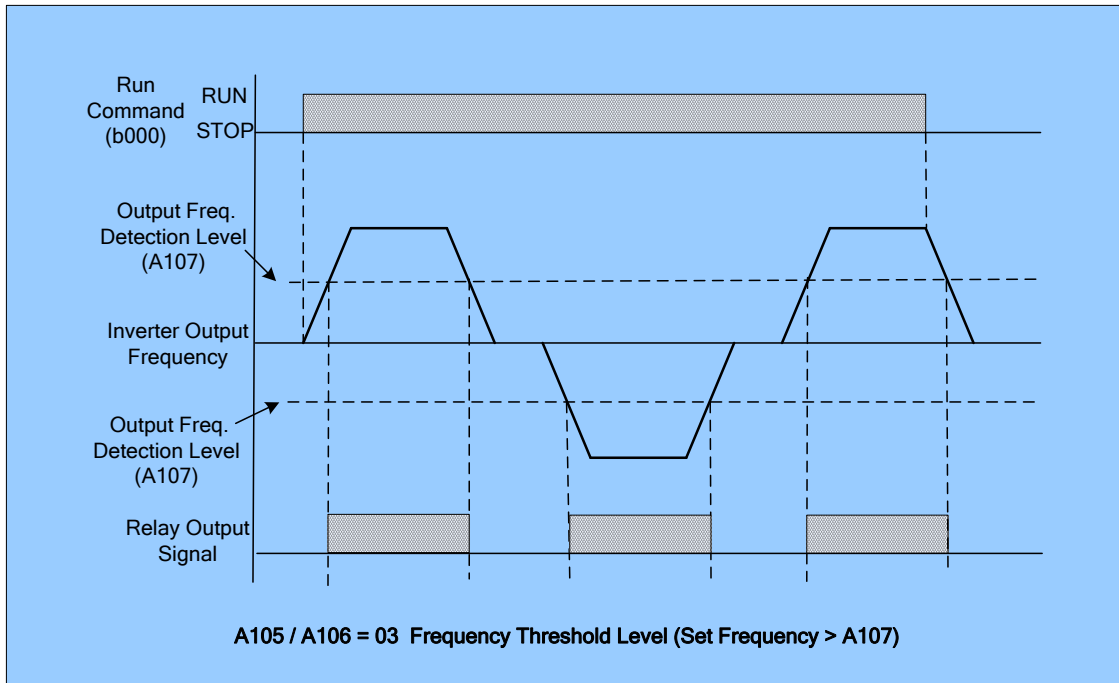

Fig. 19.21

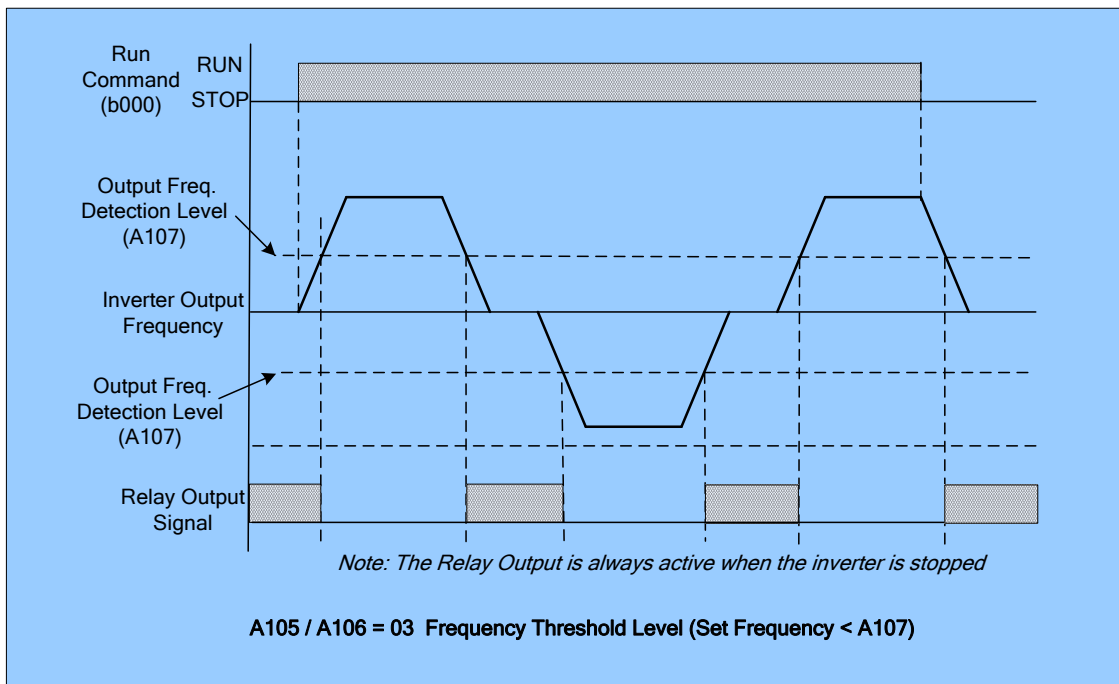

Fig. 19.22

Cont.

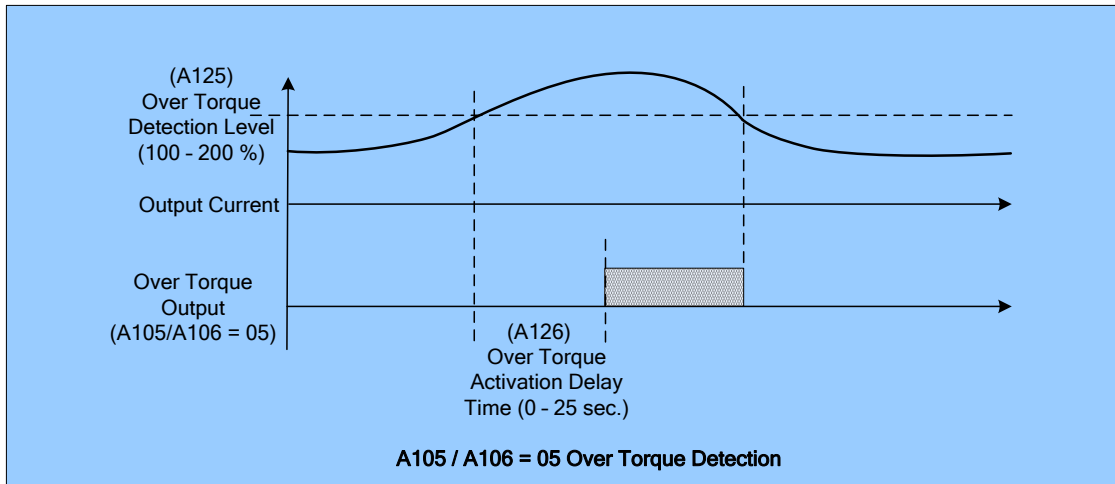

Fig. 19.23

A111	Trip Prevention Selection During Acceleration	0000: Enable Trip Prevention During Acceleration 0001: Disable Trip Prevention During Acceleration
A112	Trip Prevention Level During Acceleration	50% - 300% (based by Motor HP A003)
A113	Trip Prevention Selection During Deceleration	0000: Enable Trip Prevention During Deceleration 0001: Disable Trip Prevention During Deceleration
A114	Trip Prevention Level During Deceleration	50% - 300% (based by Motor HP A003)
A115	Trip Prevention Selection in Run Mode	0000: Enable Trip Prevention in Run Mode 0001: Disable Trip Prevention in Run Mode
A116	Trip Prevention Level in Run Mode	50% - 300% (based by Motor HP A003)
A117	Trip Prevention Deceleration Time Selection in Run Mode	0000: Trip Prevention Deceleration Time Set by b008 0001: Trip Prevention Deceleration Time Set by A118
A118	Deceleration Time in Trip Prevention Mode (sec.)	0.1 - 3600.0 Sec.

- 1.) If the acceleration time is set too short, the inverter will delay the acceleration time in order to prevent an over current trip "OC-AS".
- 2.) If the deceleration time is set too short, the inverter will delay the deceleration time in order to prevent an over voltage of DC BUS trip 'OC-C'.
- 3.) Some mechanical equipment such as presses, or a mechanical failure such as seizing due to insufficient lubrication, varying loads, etc. will cause the inverter to trip. When the operating torque of the inverter exceeds the setting of A116, the inverter will lower the output frequency at the deceleration time set by A117, and then return to normal operating frequency after the torque level stabilizes.

Cont.

A119	Electronic Motor Overload Protection Operation Mode	0000: Enable Electronic Motor Overload Protection 0001: Disable Electronic Motor Overload Protection
A120	Motor Type Selection	0000: Electronic Motor Overload Protection Set for Non-Inverter Duty Motor 0001: Electronic Motor Overload Protection Set for Inverter Duty Motor
A121	Motor Overload Protection Curve Selection	0000: Constant Torque (OL=103%)(150%, 1 minute) 0001: Variable Torque (OL=113%)(123%, 1 minute)
A122	Operation After Overload Protection is Activated	0000: Coast-to-Stop After Overload Protection Is activated 0001: Drive Will not Trip when Overload Protection is Activated (OL1)

Description of the thermal overload function:

- 1.) A121 = 0000: Protects the general mechanical load. If the load is less than 103% of rated current, the motor continues to run. If the load is larger than 150% of rated current, the motor will run for 1 minute. (See curve **A**).
 = 0001: Protects HVAC loads (fans, pumps etc.): If the load is less than 113% of rated current, the motor continues to run. If the load is larger than 123% of rated current, the motor will run for 1 minute. (See curve **B**)
- 2.) If A121 = 0000 and the motor is operating at or below a certain frequency (speed) the thermal overload action will revert from curve **A** to curve **B**.
- 3.) A120 = 0000: Set A005 as the rated frequency of the motor.
 A122 = 0000: When the thermal overload function activates, the inverter will coast to stop and the display will flash "OL1". To clear the fault press the "Reset" key on the keypad or activate the external reset to continue to run.
 = 0001: the inverter continues to run when the thermal overload activates and the display flashes "OL1" until the current declines to 103% or 113 % determined by A121.

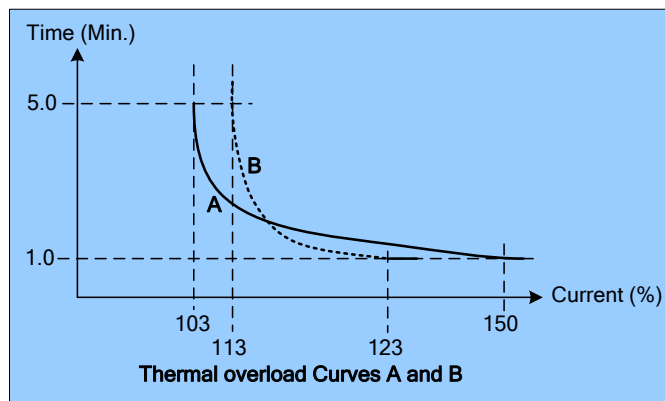

Fig. 19.24

Cont.

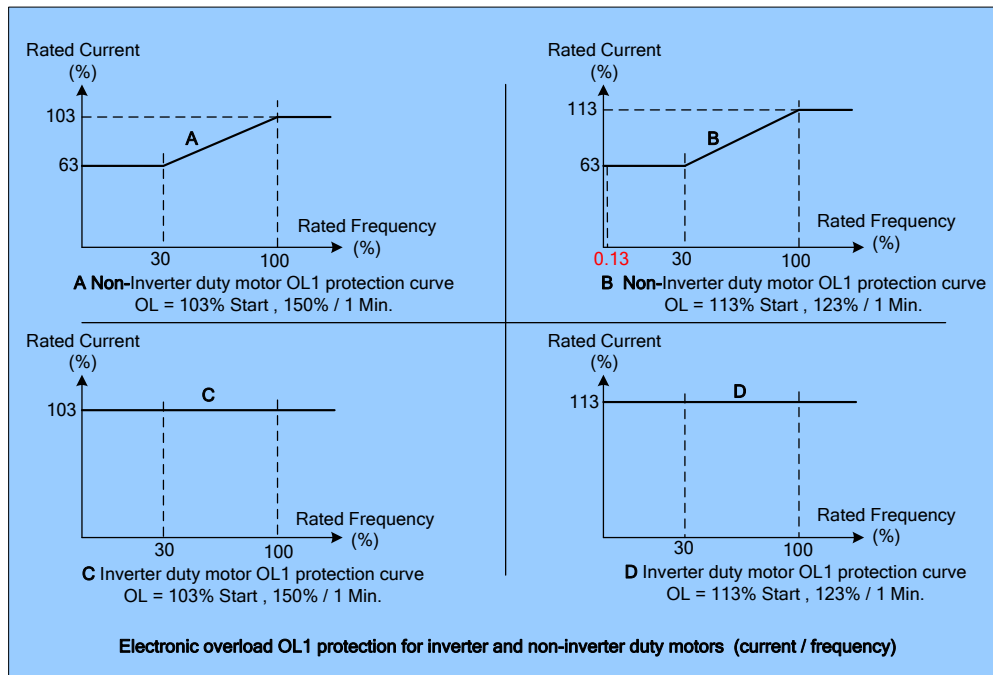

Fig. 19.25

A123	Over/Under Torque Detection Selection	0000: Disable Over/Under Torque Operation. 0001: Enable Over/Under Torque Operation Only if at Set Frequency. 0002: Enable Over/Under Torque Operation while the Drive is in Run Mode.
A124	Motor Type Selection	0000: Drive will Continue to Operate After Over/Under Torque is Activated. 0001: Coast-to-Stop After Over/Under Torque is Activated.
A125	Over Torque Threshold Level (%)	100 - 200%
A126	Over Torque Activation Delay Time (Sec.)	0.0 - 25.0 Sec.
A127	Under torque Threshold Level (%)	0 - 100 %
A128	Under torque activation Delay Time (Sec.)	0.0 - 25.0 Sec.

- Over torque is defined as when the output torque exceeds the setting of parameter A125 (Over torque threshold %) for a time exceeding the setting of parameter A126 (Over torque activation delay Sec.).

Over Torque:

A124 = 0000: When there is over torque, the inverter will continue to run and flashes “OL3” until the output torque decreases to less than the A125 set value.

= 0001: When there is over torque, the inverter coasts to stop and flashes “OL3”. After the fault clears, the “Reset” key on the keypad or external reset must be activated to restart the drive.

Note: When parameters A105 and / or A106 (Multifunction output terminal) = 05, the relay Output(s) will be activated on over torque.

- Under torque is defined as when the output torque is less than the setting of parameter A127 (Under torque threshold level %) for a time exceeding the setting of parameter A128 (Under torque activation delay Sec.).

Cont.

Under Torque:

- A124 = 0000: When there is under torque, the inverter will continue to run and flashes “OL4” until the output torque increases to more than the A127 set value.
- = 0001: When there is under torque, the inverter coasts to stop and flashes “OL4”. After the fault clears, the “Reset” key on the keypad or external reset must be activated to restart the drive.

Note: When parameters A105 and / or A106 (Multifunction output terminal) =15, the relay Output(s) will be activated on under torque.

- 3.) Over / Under torque functions are disabled when parameter A123 = 0000 and will only be active when parameter A123 = 0001 or 0002.

V/f pattern selection (0 – 18): The following fig's show the various V/f patterns using the parameter settings as specified.

A129	Torque boost gain (V/F pattern modulation)%	0.0 – 30.0 %
A130	Motor no load current(Amps AC)	-----
A131	Motor rated slip compensation(%)	0.0 - 100 %
A132	Max output frequency(Hz)	0.20 – 400.0 Hz
A133	Max output frequency voltage ratio(%)	0.0 – 100.0 %
A134	Medium frequency(Hz)	0.10 – 400.0 Hz
A135	Medium output frequency Voltage ratio (%)	0.0 – 100.0 %
A136	Min output frequency(Hz)	0.10 – 400.0 Hz
A137	Min output frequency voltage ratio (%)	0.0 – 100.0 %

- 1.) When b009 = 0018, the V/F pattern can be customized in accordance with the parameters A132 – A137 as shown in the fig. below.

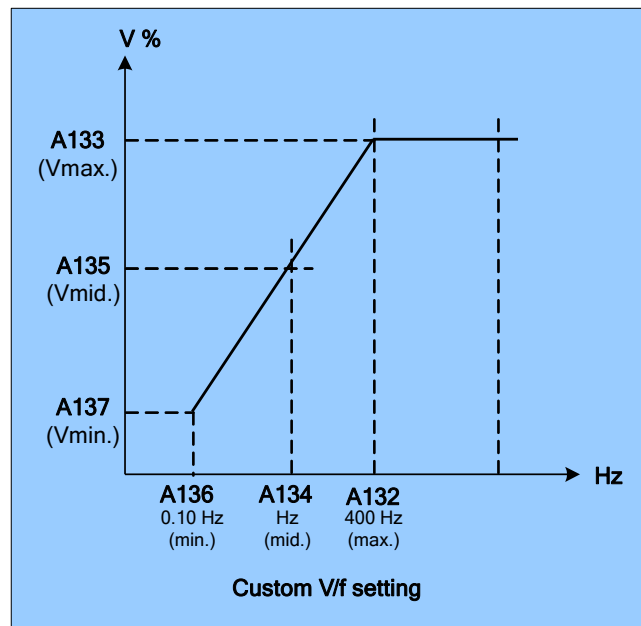

Fig. 19.26

Cont.

2.) b009 = 00 – 17 V/f Pattern (Refer to Table)

		Purpose	b009	V/f pattern			Purpose	b009	V/f pattern
50 Hz Systems	General use	General use	00		60 Hz Systems	General use	09		
			01				10		
			02				11		
			03				12		
	Decreasing torque	Decreasing torque	04			Decreasing torque	13		
			05				14		
	Constant torque	Constant torque	06			Constant torque	15		
			07				16		
			08				17		

Fig. 19.27 Pre-configured V/f Patterns Set by Parameter b009

3.) Parameter b009 (00 – 17) sets the V/f pattern. The value of the output voltage is set as a percentage of maximum by the values of B and C at the frequencies shown. The starting torque can be increased by parameter A129 (torque boost gain) as shown in the fig. below.

b009		B	C
50 Hz	60 Hz		
00	0 9	7.5%	4.5%
01	10	10%	7%
02	11	11%	8.5% / 8%
03	12	12%	9.5% / 9%
04	*	17.5%	4%
05	*	25%	5%
*	13	20.5%	7%
*	14	28.5%	8%
06	15	45.0%	1.0%
07	16	55.0%	1.0%
08	17	65.0%	1.0%

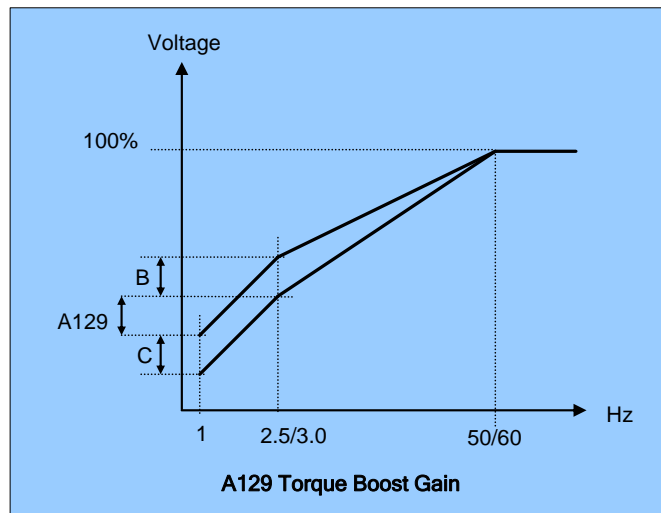

Fig. 19.28

Note: When A129=0 the torque boost function is invalid.

4.) In an induction motor, there is slip due to the load torque resulting in a decrease in motor RPM. To compensate for the speed change it is necessary to boost the output voltage. Parameter A131 (motor rated slip compensation) is used to accomplish this function and is calculated as per the following equation.

$$\text{Slip frequency boost} = \frac{\text{Output Current} - (A130)}{(A002) - (A130)} \times (A131)$$

Note : A002 = motor rated current
A130 = motor no load current

$$\text{A131 approximate value} = \frac{(\text{Motor synchronization speed} - \text{Rated speed})}{\text{Motor synchronization speed}}$$

Marked on the motor nameplate

$$\text{Motor synchronization speed (RPM)} = \frac{120}{\text{Motor Poles}} \times \text{Motor rated frequency (50Hz or 60Hz)}$$

Cont.

Example: 4 Poles, 60Hz induction motor synchronization speed $\frac{120}{4} \times 60 = 1800 \text{ RPM}$

Note: Motor no load current (A130) differs with the inverter HP capacities (see parameter A175) and should be set to actual values. (Refer to A002 note)

A140	PID Operation Selection	0000: PID disable 0001: PID enable (Deviation is D-controlled) 0002: PID Feedback D-controlled 0003: PID D Reverse characteristic controlled 0004: PID Feedback D characteristic controlled 0005: PID, Frequency command + D controlled 0006: PID, Frequency command + Feedback D controlled 0007: PID, Frequency Command + D reverse Characteristic controlled. 0008: PID, Frequency Command + Feedback D reverse Characteristic controlled.
-------------	--------------------------------	--

Please refer to the PID Block Diagram on next page, Fig 19.29.

- A140 = 0001: D is the deviation of the process error signal in unit time (A144 differential time).
- = 0002: D is the deviation of the feedback in unit time (A144 differential time).
- = 0003: D is the deviation of the process error signal in the unit time (A144 differential time). If the deviation is positive, the output frequency decreases and vice versa.
- = 0004: D is the deviation of feedback in unit time (A144 differential time). When the deviation is positive, the output frequency decreases, and vice versa.
- = 0005: D is equal to the deviation of the process error signal in unit time (A144 differential time) +Frequency command.
- = 0006: D is equal to the deviation of feedback in unit time + Frequency command.
- = 0007: D is equal to the deviation of the process error signal in unit time +Frequency command. If the deviation is positive, the output frequency decreases, and vice versa.
- = 0008: D is equal to the deviation of feedback in unit time + Frequency command. When Deviation is positive, the frequency decreases, and vice versa.

A141	Feedback Calibration Gain	0.00 – 10.00
-------------	----------------------------------	---------------------

A141 is the calibration gain. Deviation = (set point – feedback signal) × A141

A142	Proportion Gain	0.00 – 10.00
-------------	------------------------	---------------------

A142: Proportion gain for P control

A143	Integral Time (sec.)	0.0 – 100.0 Sec.
-------------	-----------------------------	-------------------------

A143: Integration time for I control

A144	Differential Time (sec.)	0.00 – 10.00 Sec.
-------------	---------------------------------	--------------------------

A144: Differential time for D control

Cont.

A145	PID Offset	0000: Positive Direction 0001: Negative Direction
A146	PID Offset Adjust (%)	-109% - +109 %

A145 / A146: PID the calculated result plus A146 (the sign of A146 is determined by A145).

A147	Output Lag Filter Time (sec.)	0.0 - 2.5 Sec.
-------------	--------------------------------------	-----------------------

A147: Update time for output frequency.

Note: The PID function is available for controlling the output flow, external fan flow and temperature (See fig. below).

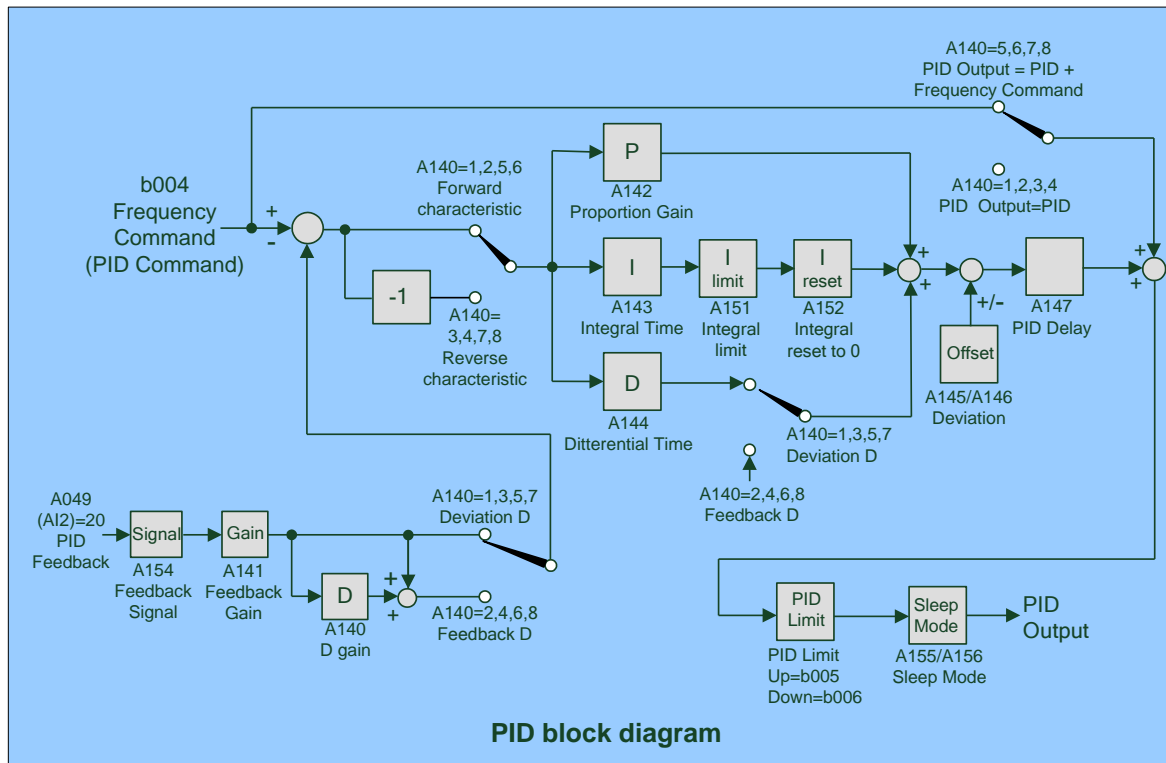

Fig. 19.29

- 1.) To enable PID control, set parameter A049 = 0020 (PID Feedback signal AI2 on TM2).
- 2.) The set point is the b004 input frequency.
- 3.) There are two ways to display the PID feedback signal: one is using the keypad display (b016 = 0001: enable PID feedback display), and the other is using analog output FM+ (A103 = 0005 PID feedback).

A148	Feedback Loss Detection Mode	0000: Disable 0001: Enable – Drive Continues to Operate After Feedback Loss. 0002: Enable – Drive “STOPS” After Feedback Loss.
-------------	-------------------------------------	---

A148 = 0: Disable.

A148 = 1: Detect, continue running, and display 'PDER'.

A148 = 2: Detect, stop, and display 'PDER'.

A149	Feedback Loss Detection Mode (%)	0 – 100 %
-------------	---	------------------

A149: Sets the percentage level for the feedback signal loss detection. The Error in percent = (Set point – feedback value). When the error is larger than the loss level setting, the feedback signal is considered lost.

A150	Feedback Loss Detection Delay Time (sec.)	0.0 -25.5 Sec.
-------------	--	-----------------------

A150: Sets the minimum time window to consider the feedback signal lost.

A151	Integrator Limit Value (%)	0 – 109 %
-------------	-----------------------------------	------------------

A151: Sets the integral limit percentage to prevent the PID from saturating.

A152	Integrator Reset to 0 when Feedback Signal Equals the set point	0000: Disable 0001: 1 Sec. 0030: 30 Sec.
-------------	--	---

A152 = 0: As the PID feedback value reaches the set point, the integrator will not be reset to 0.
A152 = 0001 or 0030: As the PID feedback value reaches the set point, the integrator will be reset to 0 in the time selected and inverter stops. The inverter will run again when the feedback value differs from the set point value.

A153	Allowable Integration Error Margin (Unit Value) (1 Unit = 1/8192)	0 - 100
-------------	--	----------------

A153= 0 - 100% unit value: After the integrator resets to 0 the error margin will restart.

A154	AIN and AI2 Signal Type	0000: AIN = 0 - 10V or 0-20 mA, AI2 = 0 - 10V or 0-20 mA 0001: AIN = 0 - 10V or 0-20 mA, AI2 = 2 - 10V or 4-20 mA 0002: AIN = 2 - 10V or 4-20 mA, AI2 = 0 - 10V or 0-20 mA 0003: AIN = 2 - 10V or 4-20 mA, AI2 = 2 - 10V or 4-20 mA
-------------	--------------------------------	--

Note: The signal type V or I is set via switches SW2 and SW3 on the control board.

A155	Sleep Function Operation Level (Hz)	0.00 – 400.00 Hz
A156	Sleep Function Delay Time (sec.)	0.0 – 25.5 Sec.

A155: Sets the sleep threshold frequency.

A156: Sets the time for sleep delay.

- 1.) When the PID output frequency is less than the sleep threshold frequency A155 exceeding the time of sleep delay set by A156, the inverter will decelerate to 0 and enter PID sleep mode. When the PID output frequency is greater than the sleep threshold frequency A155 the inverter will reactivate and enter the PID wake mode. The time diagram is shown in the first fig, on the next page.
- 2.) Parameters A140 = 1(PID enable), A049 = 20(PID feedback enable), b004 = PID setting frequency source (target value) are set as shown in first fig, on the next page

Cont.

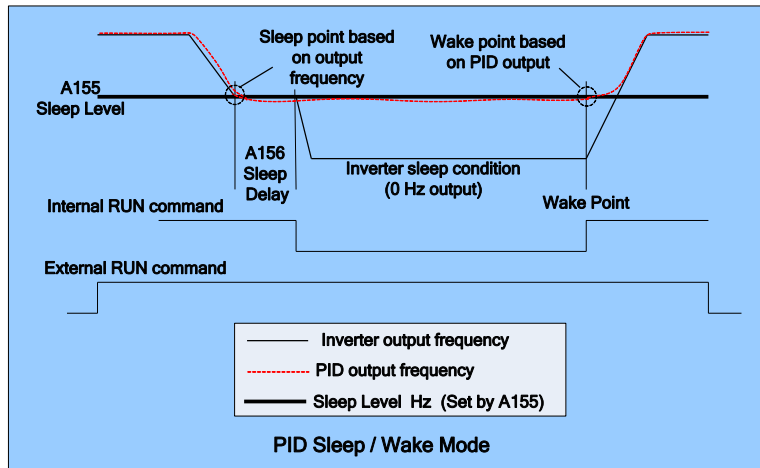

Fig. 19.30

*A157	Engineering Units	0000: None	0012: inW (inches in water column)
		0001: FPM (feet per minute)	0013: HP
		0002: CFM (cubic feet per minute)	0014: m/s (meters per second)
		0003: PSI (pounds per square inch)	0015: MPM (meters per minute)
		0004: GPH (gallons per hour)	0016: CMM (cubic meters per minute)
		0005: GPM (gallons per minute)	0017: W
		0006: in	0018: kW
		0007: ft	0019: m
		0008: /s (units per second)	0020: °C
		0009: /m (units per minute)	0021: %
		0010: /h (units per hour)	0022: rpm
		0011: °F	0021: %

*A158	PID Feedback Display Unit Max.	0 - 9999
*A159	PID Feedback Display Unit Min.	0 - 9999

A158 and A159: Allow the selected engineering units to be scaled. (See Fig. 19.31 below)

* Can only be used with LCD display.

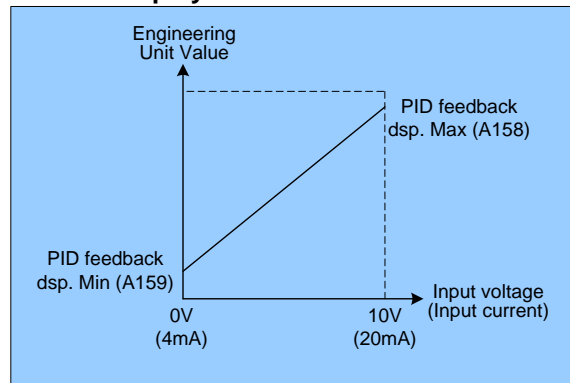

Fig. 19.31

A161	Communication time-out Operation selection.	0000: Deceleration to stop (b008: Deceleration time 1). 0001: Free run to stop. 0002: Deceleration to stop (A026: Deceleration time 2). 0003: Continue operating.
A162	Communication time-out Detection time.	00.0 – 25.5 Sec.

A161: Selects the time-out operation. (See diagram below)

- 1.) Reset method:
 - a. Push the “Reset” button directly.
 - b. Receive Modbus data from Master.
- 2.) After communication time-out, the motor decelerates to stop (A161 = 0000, 0001, 0002). The motor does not run after reset. The inverter must send the run command to restart.
- 3.) The setting of parameter A161 cannot be modified during communication.

A162: Selects the time-out detection time.

- 1.) Communication time-out detection is enabled or disabled by parameter A162 and does not affect the Run / Frequency command.
- 3.) The setting of parameter A162 cannot be modified during communication.

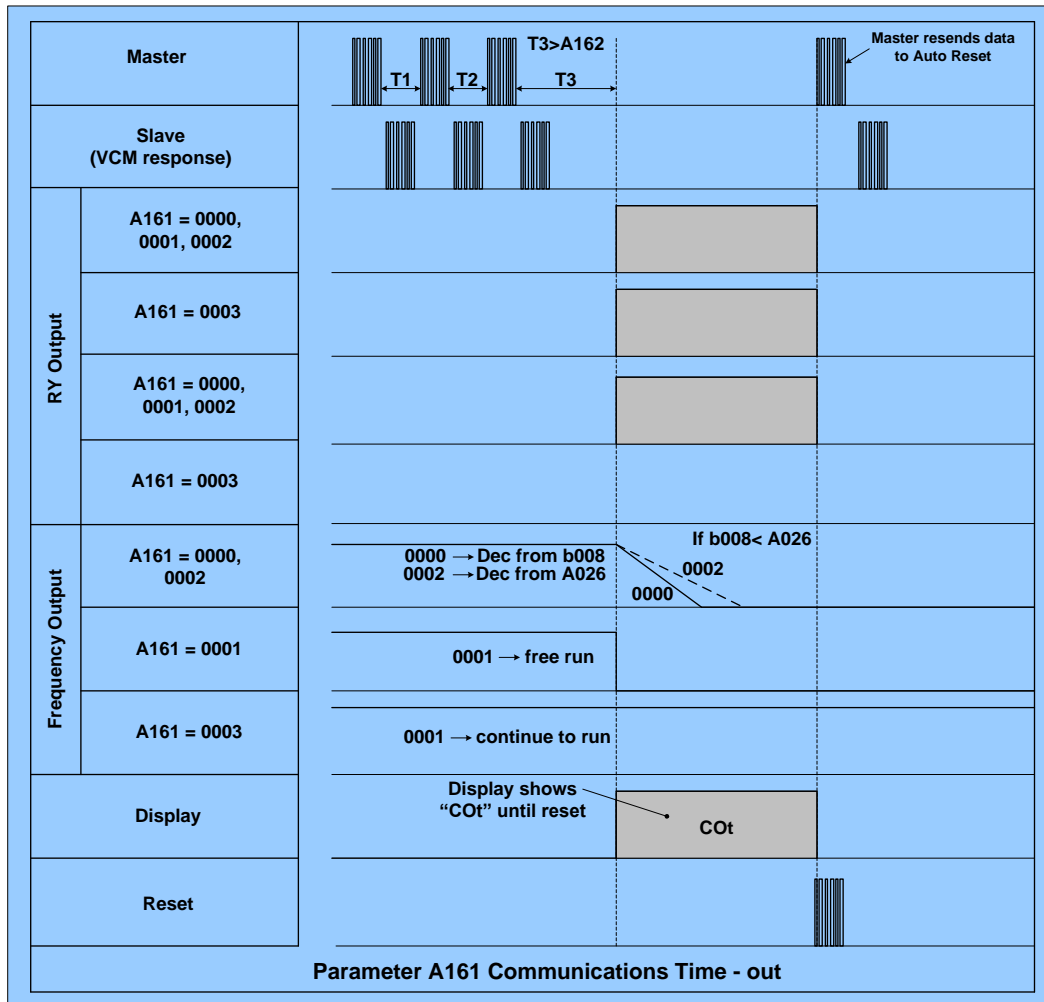

Fig. 19.32

A163	RS485 Communication Station Drop Number	1 - 254
-------------	--	----------------

A163: Assigns a node number to a specific inverter when networking multiple inverters using RS485 protocol.

A164	Baud Rate setting (bps)	0000: 4800 0001: 9600 0002: 19200 0003: 38400
A165	Stop Bit Selection	0000: 1 stop bit 0001: 2 stop bit
A166	Parity Selection	0000: no parity 0001 even parity 0002: odd parity
A167	Data Format Selection	0000: 8 bit data 0001: 7 bit data

- 1.) RS485 Communication:
 - A. 1 to 1 control: A host controller controls one inverter, set A163 = 001 to 254.
 - B. 1 to multiple inverter control: A host controller can control up to a maximum of 32 inverters. Use parameter A163 to set the communication address (001 - 254). When the communication address = 000, the inverter is controlled by serial communication regardless of the A163 setting.
- 2.) RS-232communication: (*an RS232 interface is required*)
 - 1 to 1 control: A host controller controls one inverter, set A163 = 1 to 254.

Notes:

- a. The baud rate A164 and the communications format A165, A166 and A167 of the host controller must match that of the inverter.
- b. The inverter will validate the modified parameters after the parameters are modified by the host controller.
- c. For the communication protocol, refer to the VCM MODBUS communication protocol manual.
- d. Parameters A163 – A167 cannot be changed via the communication module.

A168	Stator Resistance(Ohms)	-----
A169	Rotator Resistance(Ohms)	-----
A170	Equivalent Inductance(mH)	-----
A171	Magnetized Current(Amps AC)	-----
A172	Ferrite Loss Conduction (gm)	-----

- 1.) Parameters A168 – A172 are automatically set (factory default) with the HP code A175. (Refer to *Appendix B*)
- 2.) If A000 is set to = 0 or 1(vector control mode), on power up, set A006 =1 (auto-tuning). The motor operates with the inverter to perform auto tuning. Once the motor stops, auto tuning is completed and the inverter will write the internal parameters of the motor to A168 - A172. A006 will automatically be reset to 0 and the display will read END.

Note: Do not perform auto-tuning with the mechanical load connected to the motor.

- 3.) Auto tuning must be carried out whenever the motor is changed. If the internal parameters are known, they can be input directly to A168 - A172.
- 4.) Parameters A168 – A172 are only effective in when A000 = 0 or 1 (vector control mode).
- 5.) Only perform the auto tune when the inverter and motor are not connected.

A175	Drive Horsepower Code	See table below
-------------	------------------------------	------------------------

A175	Inverter Model
2P5	2P5-1P/P
201	201-1P/P
202	202-1P/P
203	203-1P/P
205	205-P
207	207-P
210	210-P
215	215-N
220	220-N
225	225-N
230	230-N
240	240-N

A175	Inverter Model
401	401-P
402	402-P
403	403-P
405	405-P
407	407-P
410	410-P
415	415-P
420	420-N
425	425-N
430	430-N
440	440-N
450	450-N
460	460-N
475	475-N

A176	Software Version	XXXXXXX
-------------	-------------------------	----------------

A177	Fault Log (Latest 3 times)	X.XXXX
-------------	-----------------------------------	---------------

- 1.) When the inverter trips on a new fault, the fault that is stored in 1.xxxx will be transferred to 2.xxxx, and the fault stored in 2.xxxx will be transferred to 3.xxxx. The current fault will then be stored in 1.xxxx. So the most recent fault will always be stored in 1.xxxx and the oldest in 3.xxxx.
- 2.) When pressing 'ENTER' at A177, the most recent fault 1.xxxx will be displayed first. Pressing ▲ will display 2.xxx→3.xxx→1.xxx. Pressing ▼ will display 2.xxx→1.xxx→3.xxx.
- 4.) To clear the fault log, press 'ENTER' at A177 and the reset key at the same time. The fault log content will change to 1.---,2.---,3.---

A178	Accumulated Operation Time 1 (Hours)	0 – 9999 Hours
A179	Accumulated Operation Time 2 (Hours X 10000)	0 – 27 (Hours X 10000)
A180	Accumulated Operation Time Mode	0000: Power on time 0001: Operation time

- 1.) When the operating time accumulated in A178 reaches 9999, and the next hour expires, A179 will be set to = 01 (10000 hours) and A178 will be reset to 0000.
- 2.) A180: Mode of accumulated time selection:

A180	Description
0	Count the accumulated time when power is applied.
1	Count the accumulated time when the Inverter is operating.

A181	Reset to the factory setting	1110: Reset to the 50Hz factory setting 1111: Reset to the 60Hz factory setting
-------------	-------------------------------------	--

A181: Is set to 1110 when the inverter is used with motors rated at 50Hz.

A181: Is set to 1111 when the inverter is used with motors rated at 60Hz.

Note:

Motor parameters (A168 - A172) will be modified when in V/F control mode after a factory reset is performed.

Motor parameters (A168 - A172) will not be modified when in vector control mode after a factory reset is performed.

After a reset to factory setting, the Axxx parameters will become inaccessible. Parameter b011 must then be set to 0001 to enable access to the A parameters.

NOTES:

20.0 Option Modules and Cables

The following Option Modules are available for the **VCM** Inverter series. They are easily installed and are inserted into connector **CON2** by removing the front cover.

⚠ CAUTION
When installing option modules, make sure that power has been removed from the inverter and that the charge indicator is extinguished before proceeding.

Remove the front cover in accordance with the model being used (See Appendix D). After the option module has been installed, replace the cover before powering-up the inverter. **Do not operate the inverter with the cover removed.**

20.1 Option Module Part Numbers

Option Part Number	Description	*Keypad Remote Cable Kit		FIG. No.
		Part Number	Length Ft./ M	
VCM – LED – W	Remote LED Keypad	SW305P	1.6 / 0.5	20.1.1 & 20.1.2
<i>*Select the desired cable length from table</i>		SW3001	3.3 / 1.0	
VCM – LCD – W	Remote LCD Keypad	SW3002	6.6 / 2.0	
		SW3003	9.8 / 3.0	
		SW3005	16.4 / 5.0	
SIF - 485	RS485 Interface	x		20.1.3
SIF - 232	RS232 Interface	x		20.1.4
SIF - MP	Copy Module	x		20.1.5
PDA Link	SIF - 232	RS232 Interface	x	20.1.6

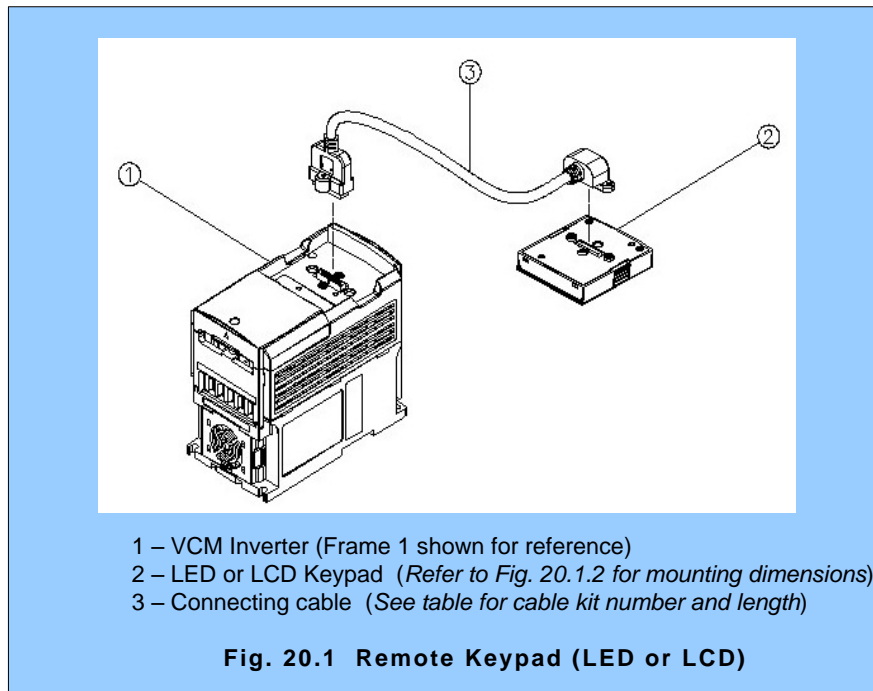

Cont.

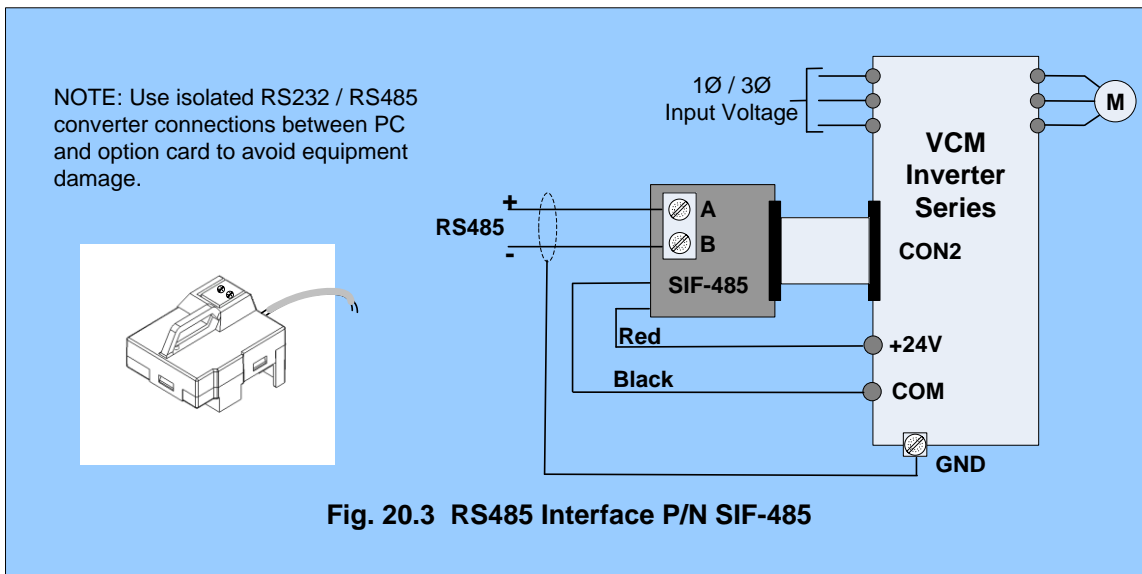
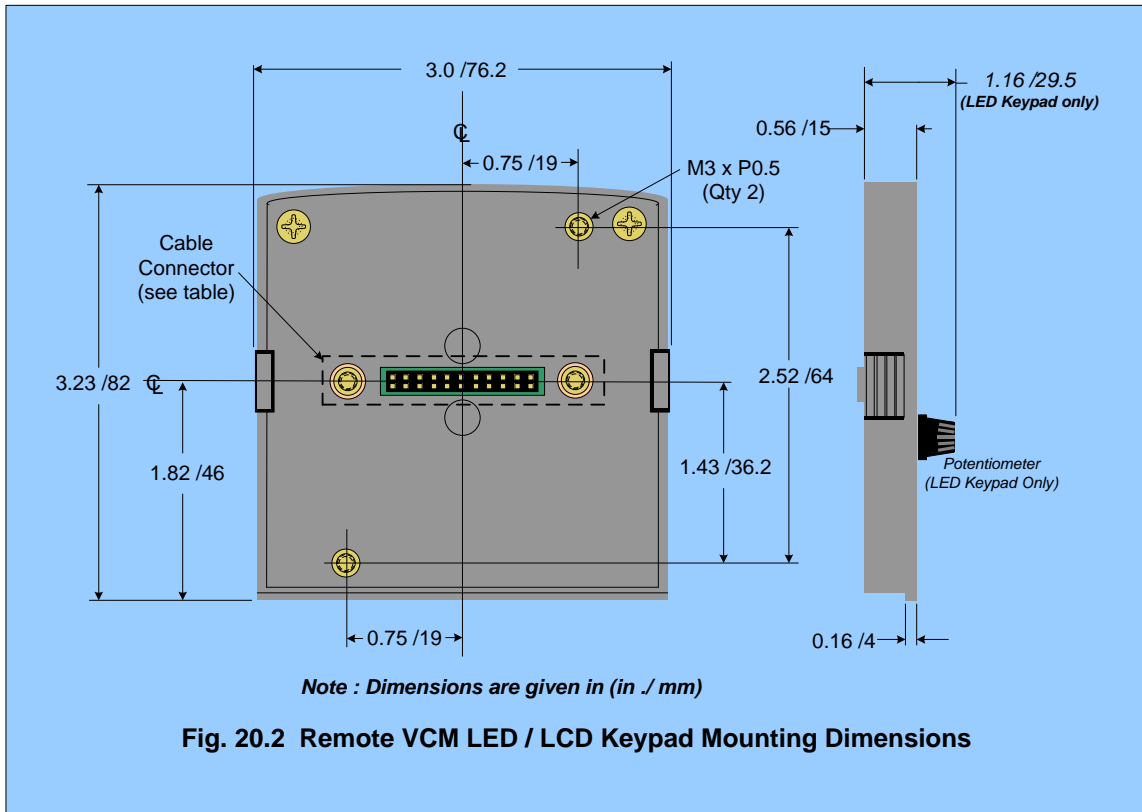

Cont.

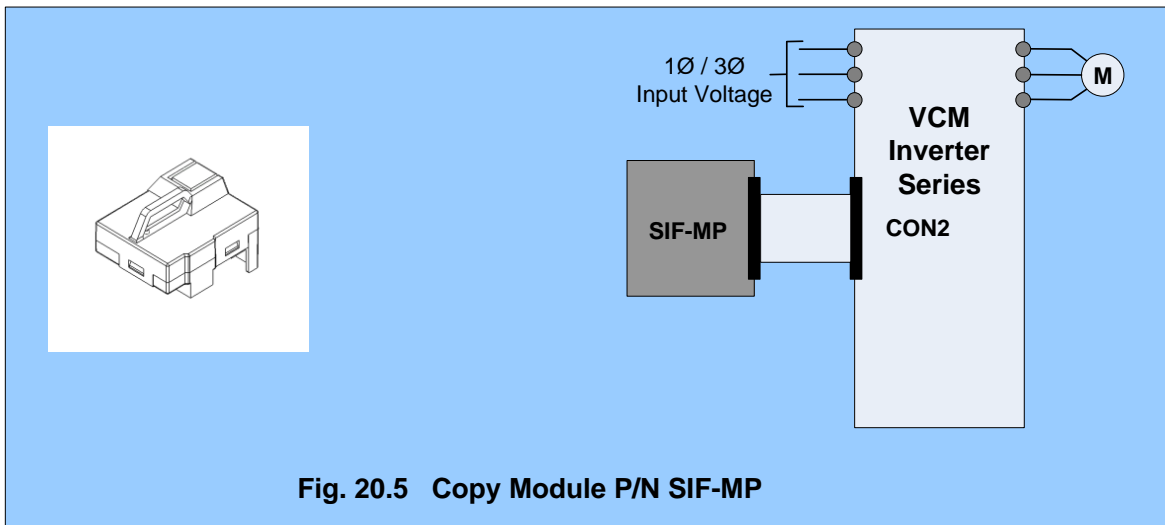
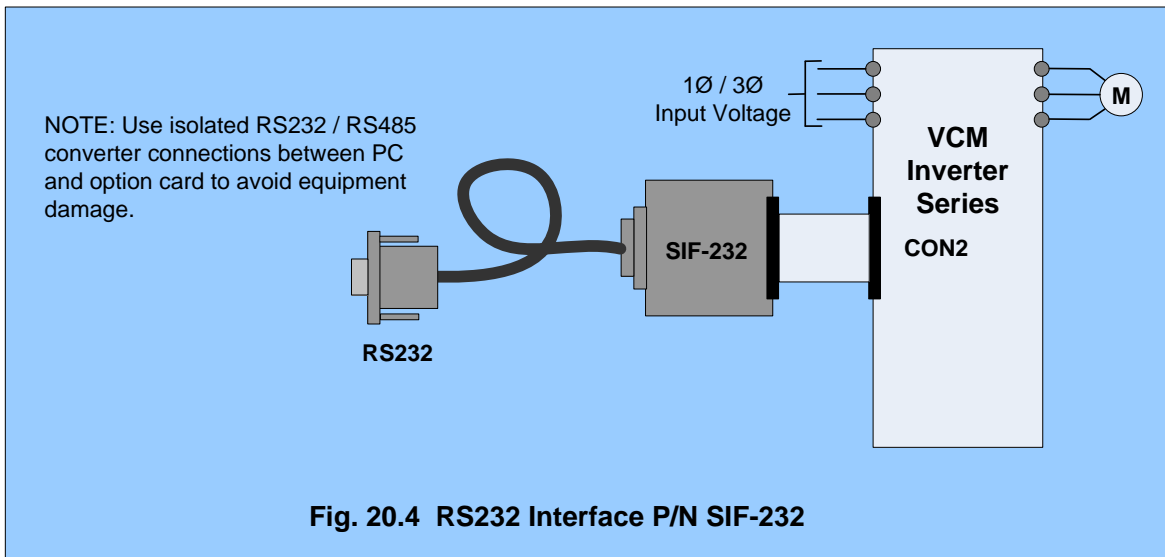

NOTES:

21.0 Error Display Codes

The following tables describe the error codes that are displayed under fault conditions. They are broken down into five categories:

- Unresettable / Unrecoverable errors
- Errors recoverable both manually and automatically
- Manually recoverable errors Only (*no auto-restart*)
- Set-up configuration and interface errors
- Keypad errors

Some of the faults can be reset manually via the **Reset** key, or by an **external reset** command. Certain faults can also be reset by setting parameter A018 (Enable Auto Restart). Other faults are **not resettable**. In this case, the inverter may need total replacement or a part replaced.

21.1 Unresettable / Unrecoverable Errors

Display Code	Fault	Cause	Remedy
CPF	Program problem	External noise interference. (EMI)	<i>Connect a parallel RC suppressor across the coil of the magnetic contactor that is causing the interference.</i>
EPR	EEPROM problem	Faulty EEPROM	<i>Replace EEPROM</i>
*-OV-	Overvoltage while stopped	Voltage detection circuit Malfunction.	<i>Repair or replace unit.</i>
*-LV-	Undervoltage while stopped	1. Input voltage too low. 2. Power resistor or fuse burned out. 3. Detection circuit malfunctions.	1. <i>Verify that the input voltage is correct.</i> 2. <i>Replace the power resistor or fuse.</i> 3. <i>Repair or replace the inverter.</i>
*-OH-	The inverter overheats while stopped	1. Detection circuit malfunction. 2. Ambient temperature too high or poor ventilation.	1. <i>Replace or return the inverter.</i> 2. <i>Improve ventilation conditions.</i>
CTER	Current transducer detection error	Current transducer or circuit error.	<i>Repair or replace unit.</i>

***The Fault relay contact does not operate with these error indications.**

21.2 Automatically and Manually Recoverable Errors

Display Code	Fault	Cause	Remedy
OC-S	Overcurrent at start	1. Motor winding and frame short circuit. 2. Motor and ground short circuit.. 3. Power module is damaged.	1. <i>Inspect the motor.</i> 2. <i>Inspect the wiring.</i> 3. <i>Replace the power module.</i>

Display Code	Fault	Cause	Remedy
OC-A	Overcurrent at acceleration	<ol style="list-style-type: none"> 1. Acceleration time is set too short. 2. The capacity of the motor exceeds the capacity of the inverter. 3. Short circuit between the motor winding and the frame. 4. Short circuit between motor wiring and ground. 5. IGBT module is damaged. 	<ol style="list-style-type: none"> 1. <i>Set a longer acceleration time. (Parameter b0007)</i> 2. <i>Replace inverter with the same or greater capacity as that of the motor.</i> 3. <i>Check the motor.</i> 4. <i>Check the wiring.</i> 5. <i>Replace the IGBT module.</i>
OC-C	Overcurrent during run	<ol style="list-style-type: none"> 1. Transient load change. 2. Transient power change. 	<ol style="list-style-type: none"> 1. <i>Increase the capacity of the inverter.</i> 2. <i>Repeat parameter auto tuning. (A006 = 1)</i> 3. <i>Reduce stator resistance (A168) if the above actions are ineffective.</i>
OV-C	Overvoltage during operation/ deceleration	<ol style="list-style-type: none"> 1. Deceleration time setting too short or excessive load inertia. 2. Input voltage varies widely. (fluctuates) 	<ol style="list-style-type: none"> 1. <i>Set a longer deceleration time.</i> 2. <i>Add a braking resistor or braking unit.</i> 3. <i>Add a reactor to the input line side.</i> 4. <i>Increase inverter capacity.</i>
Err4	Illegal interrupt of CPU	Outside noise interference.	<i>Return unit if this is a frequent occurrence.</i>
OVSP	Over speed during operation	<ol style="list-style-type: none"> 1. Motor load excessive or inverter capacity too small. 2. Motor parameter error. (vector mode) 3. The gain is excessive in vector mode. 4. Current detection circuit fault. 	<ol style="list-style-type: none"> 1. <i>Increase acceleration / deceleration time.. (Parameters b007 / b008)</i> 2. <i>Check and correct motor parameter.</i> 3. <i>Change stator Resistance gain and Rotor resistance gain. (Parameters A168 / A169), (suggest Incremental decrease of 50-100)</i> 4. <i>Return unit.</i>

Cont.

21.3 Manually Recoverable Errors Only (no auto-restart)

Display	Fault	Cause	Remedy
OC	Over-current during stop	1. OC detection circuit malfunction. 2. Bad connection for CT signal cable.	<i>Send the inverter back for repair.</i>
OL1	Motor overload	1. Motor under-sized. 2. Improper settings for Parameters A002 and A119-A122.	1. <i>Increase motor capacity.</i> 2. <i>Set A002, A119 - A122 accordingly.</i>
OL2	Inverter overload	Excessive Load.	<i>Increase the inverter capacity.</i>
OL3	Over torque	1. Excessive Load. 2. Improper settings of parameters A125 and A126	1. <i>Increase the inverter capacity.</i> 2. <i>Set A125 and A126 accordingly.</i>
LVC	Undervoltage during operation	1. Input voltage too low. 2. Input voltage varies widely. (fluctuates) 3. Main Circuit Relay error.	1. <i>Improve input voltage quality or increase the value of parameter A014.</i> 2. <i>Set a longer acceleration time. (Parameter b0007)</i> 3. <i>Add a line reactor to the input side.</i> 4. <i>Send the inverter back for repair.</i>
OH-C	Heat-sink temperature too high during operation	1. Excessive load. 2. Ambient temperature too high or poor ventilation.	1. <i>Check the load.</i> 2. <i>Increase inverter capacity.</i> 3. <i>Improve ventilation conditions.</i>

21.4 Set –up Configuration and Interface Errors

Display	Fault	Description
STPO	Zero speed stop	<i>Set frequency <0.1Hz Increase set frequency</i>
STP1	Fail to direct start on power up	1. <i>If the inverter is set for external terminal control mode (b000=1), and direct start on power up is disabled (A017 = 0001), the inverter cannot be started and will flash STP1 when the run switch is ON and power is applied. (Refer to descriptions of A017).</i> 2. <i>Set A017 = 0001 for direct start.</i>

Cont.

STP2	Keypad emergency stop	<ol style="list-style-type: none"> 1. If the inverter is set to external control mode ($b000 = 0001$), and the Stop key is pressed ($A010 = 0000$), the inverter will stop based on the setting of $B003$ and STP2 will flash. Turn the run switch to OFF and then ON again to restart the inverter. 2. If the inverter is in communication mode and the Stop key is pressed ($A010 = 0000$), the inverter will stop based on the setting of $b003$ and STP2 will flash. The PLC or PC must send a Stop command then a Run command to the inverter for it to be restarted. 3. The Stop key cannot perform an emergency stop when $A010 = 0001$.
E.S.	External emergency stop	The inverter will decelerate to stop and flashes E.S., when there is an external emergency stop signal via the Control input terminals. (See parameters A050-A056).
b.b..	External base block	The inverter stops immediately (motor coasts to stop) and then flashes b.b., when external base block is input through the multi-functional input terminal. (See parameters A050 - A056).
ATER	Auto-tuning faults	<ol style="list-style-type: none"> 1. Motor data error resulting in auto-tuning failure. 2. Stopping the inverter during Auto-tuning before completion.
PDER	PID feedback signal loss	PID feedback signal circuit error detection.

21.5 Keypad Errors

Display	Error	Cause	Remedy
LOC	Parameter and frequency reverse modifications locked out	<ol style="list-style-type: none"> 1. Attempt to modify frequency parameter while $A039 > 0000$. 2. Attempt to reverse while $b002 = 0001$. 	<ol style="list-style-type: none"> 1. Set $A039 = 0000$. 2. Set $b002 = 0000$.
Err1	Keypad operation error	<ol style="list-style-type: none"> 1. Attempt to press ▲ or ▼ keys when $b004 > 0$ or in speed operation. 2. Attempt to modify parameters, which cannot be modified during Run. (see parameter list) 	<ol style="list-style-type: none"> 1. The ▲ or ▼ is available for modifying the parameter only when $b004=0$. 2. Modify the parameters only in stop mode.
Err2	Parameter setting error	<ol style="list-style-type: none"> 1. The setting of $b006$ is within ranges of parameters $A032 \pm A035$ or $A033 \pm A035$ or $A034 \pm A035$. 2. $b005 \leq b006$. 3. Setting error while performing Auto-tuning. (e.g. $b000 \neq 0$, $b004 \neq 0$) 	<ol style="list-style-type: none"> 1. Modify $A032$-$A034$ or $A035$. 2. $b005 > b006$. 3. Set $b000 = 0$, $b004 = 0$ during Auto tuning.
Err5	Modification of parameter is not allowed during communication	<ol style="list-style-type: none"> 1. Enable command disabled during communication. 2. Modify parameters A164 -167 during communication. 	<ol style="list-style-type: none"> 1. Issue enable command before / while Communicating. 2. Set parameters 164-167 before communicating.

Err6	Communication failure	<ol style="list-style-type: none"> 1. Faulty / incorrect wiring. 2. Incorrect settings of communication parameters. 3. Check-sum error 4. Incorrect communication verification. 	<ol style="list-style-type: none"> 1. <i>Check hardware and wiring.</i> 2. <i>Check parameters A161 – A164.</i>
Err7	Incorrect parameter settings	<ol style="list-style-type: none"> 1. Attempt to change A175. 2. Voltage and current detection circuits are malfunctioning. 	<i>Reset inverter or contact technical support.</i>
EPr1	Parameter set error, Copy unit failed	<ol style="list-style-type: none"> 1. Can not connect with Copy unit. 2. Copy unit failure. 3. The HP rating on Copy unit and the inverter are different. 	<ol style="list-style-type: none"> 1. <i>Modify parameter A040.</i> 2. <i>Change copy unit.</i> 3. <i>The HP rating need to be the same.</i>
EPr2	Parameters do not match	Copy the parameter to the inverter to verify the parameters do not match.	<ol style="list-style-type: none"> 1. <i>The voltage and HP rating of the Copy unit is different than the inverter.</i> 2. <i>Change copy unit.</i>

NOTES:

22.0 Troubleshooting

The following troubleshooting section includes both general troubleshooting and flow chart guidance. The flowcharts include:

- Fig. 22.1.1 Fault Display Troubleshooting
- Fig. 22.1.2 OC and OL Fault Troubleshooting
- Fig. 22.1.3. OV and LV Fault Troubleshooting
- Fig. 22.1.4 Motor Will Not Run
- Fig. 22.1.5 Motor Overheating
- Fig. 22.1.6 Motor Instability

 **DANGER**

Use extreme caution when troubleshooting as lethal voltages are present.

Cont.

22.1 General Troubleshooting

Fault Status	Check That:	Remedy
Motor will not run	there is power applied to terminals L1(L), L2, and L3(N) (L1(L) and L3(N) for single phase units)	<ul style="list-style-type: none"> • Apply power • Turn power OFF and then ON again. • Make sure the input voltage is correct. • Make sure the power input terminal screws are firmly secure.
	the <i>Charge</i> indicator is lit.	
	there is voltage on output terminals T1, T2, and T3 to the motor.	Turn the power OFF and then ON again.
	there is not an overload causing the motor to stall	Reduce the load so the motor will run.
	there are not any inverter wiring problems.	Correct wiring or any input connection problems.
	there is a forward or reverse run command.	
	there is a Run command.	<ul style="list-style-type: none"> • Make sure that the analog frequency input signal wiring is correct. • Make sure that the signal input voltage value is correct.
the operational mode is correct.	Operate the inverter through the digital keypad.	
Motor runs in wrong direction	the wiring for output terminals T1, T2, and T3 is correct.	The wiring must match the U, V, and W terminals of the motor.
	the wiring for the forward and reverse signals is correct.	Correct wiring if necessary.
Motor speed can not be regulated	the signal wiring for the analog input frequency is correct.	Correct wiring if necessary.
	the setting of operation mode is correct..	Check the operation mode on the keypad.
	the load on the motor is not too excessive.	Reduce the load.
Motor speed too high or too low	the specifications for the motor (poles, voltage etc...) are correct.	Confirm the motor specifications.
	the gear ratio is correct.	Confirm the gear ratio.
	the setting of the maximum output frequency is correct.	Confirm the maximum output frequency.
Motor speed varies erratically	the load is too excessive.	Reduce the load.
	the load does not vary excessively.	<ul style="list-style-type: none"> • Minimize the variation of the load. • Increase capacities of the inverter and the motor.
	the input power is not erratic or there is a phase loss occurring.	<ul style="list-style-type: none"> • Add an AC reactor at the power input side if using single-phase power. • Check wiring if using three-phase power.

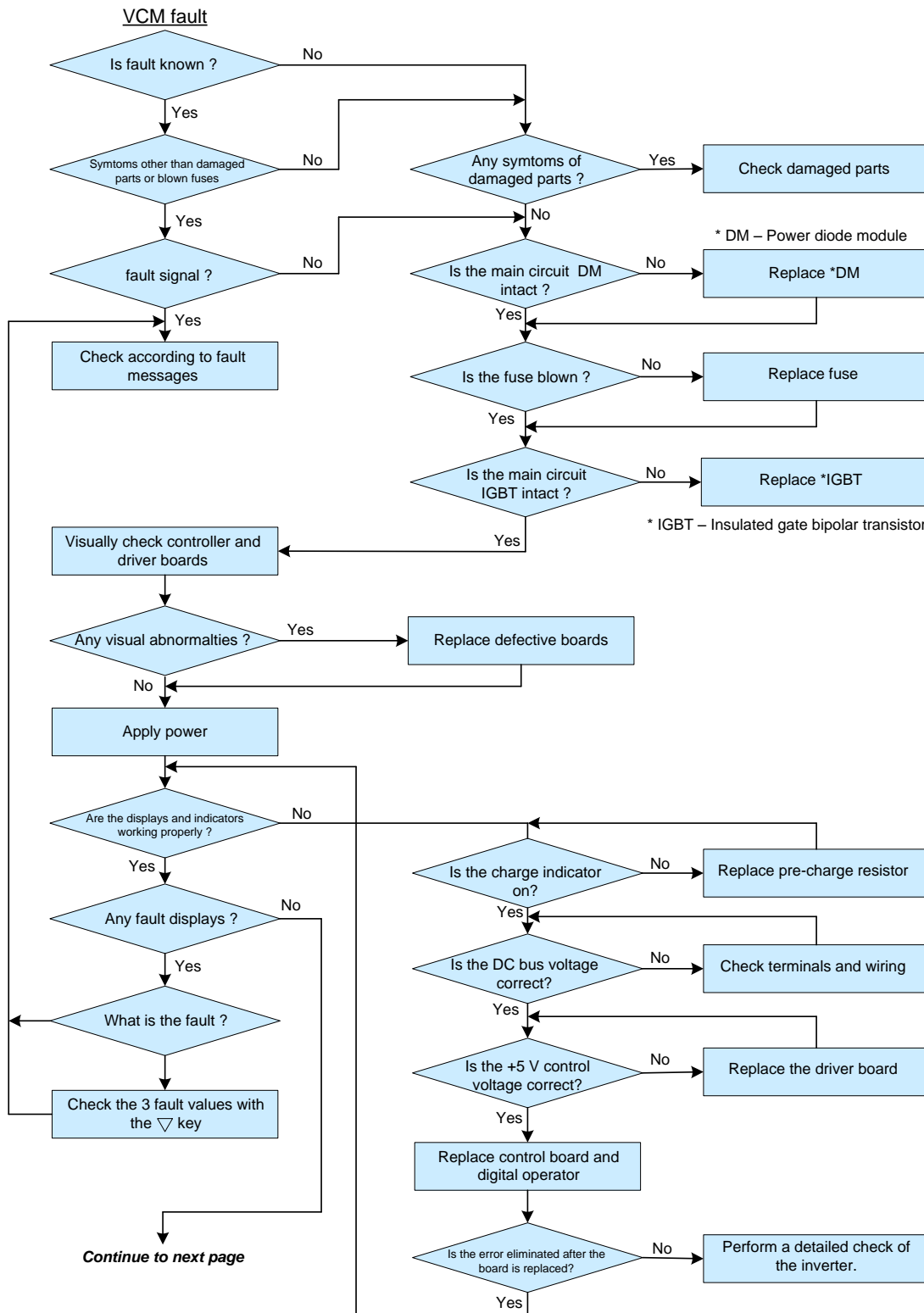

Fig. 22.1 Fault Display Troubleshooting

Cont.

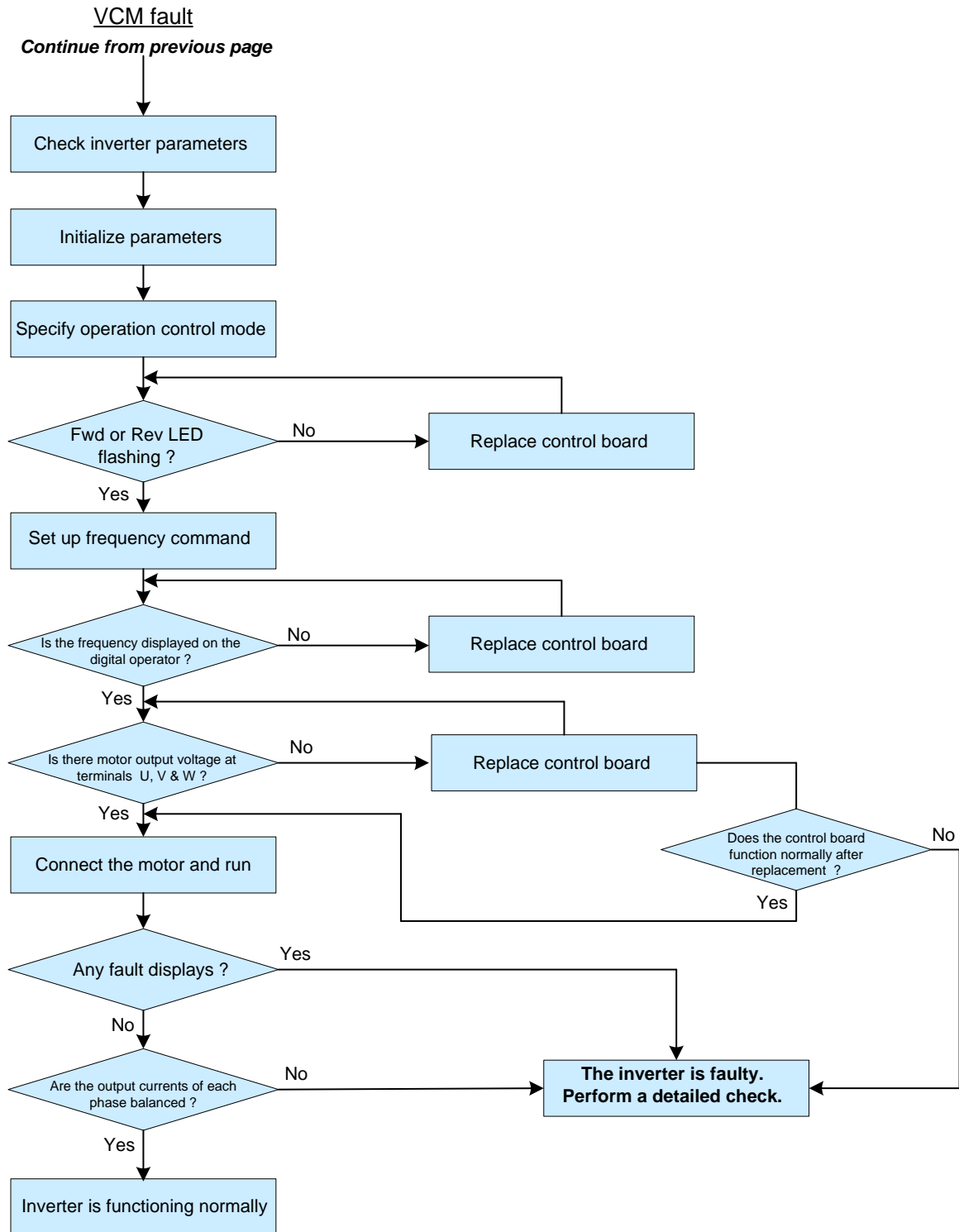

Fig. 22.1 Fault Display Troubleshooting Cont.

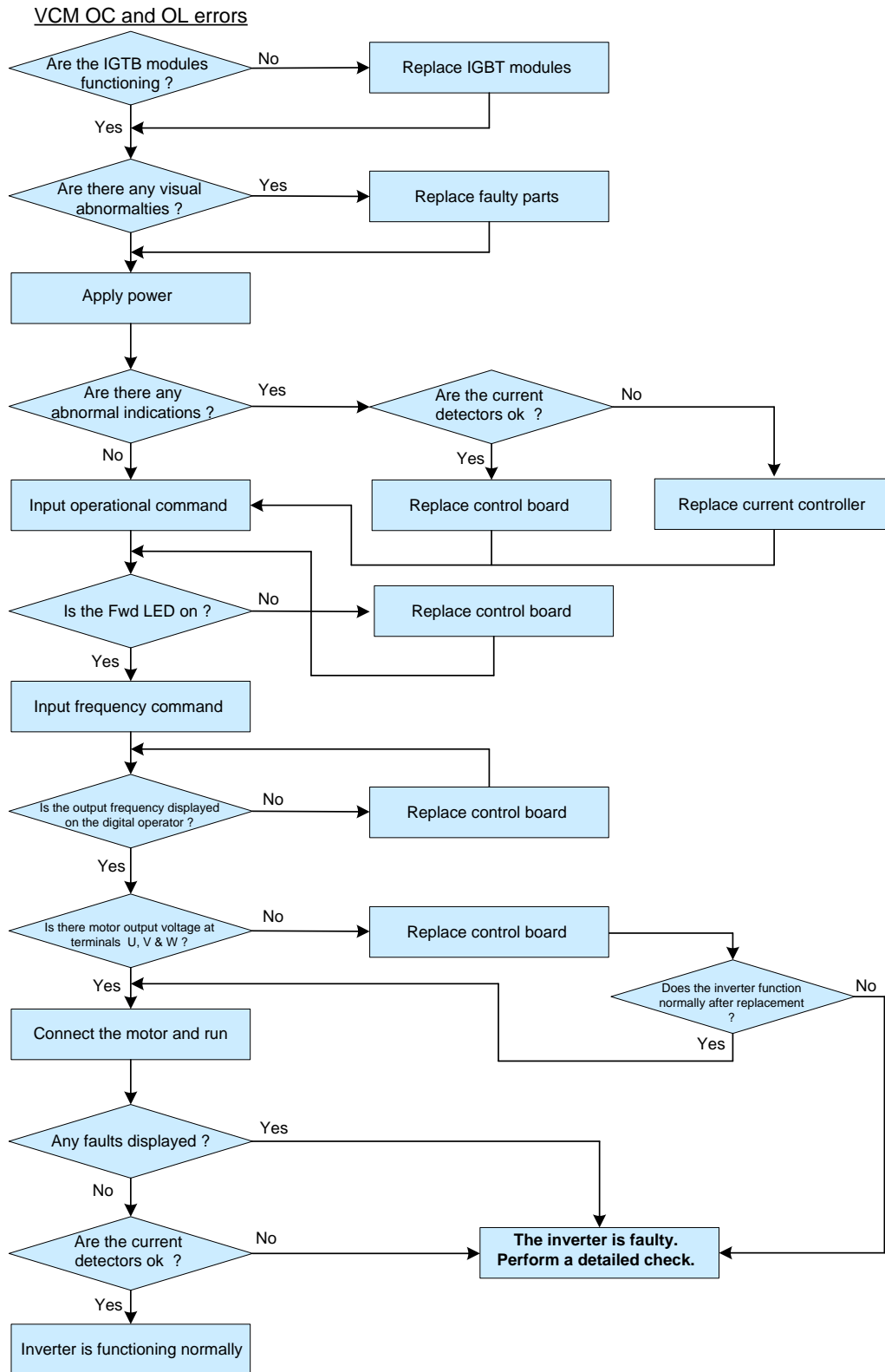

Fig. 22.2 OC and OL Error Troubleshooting

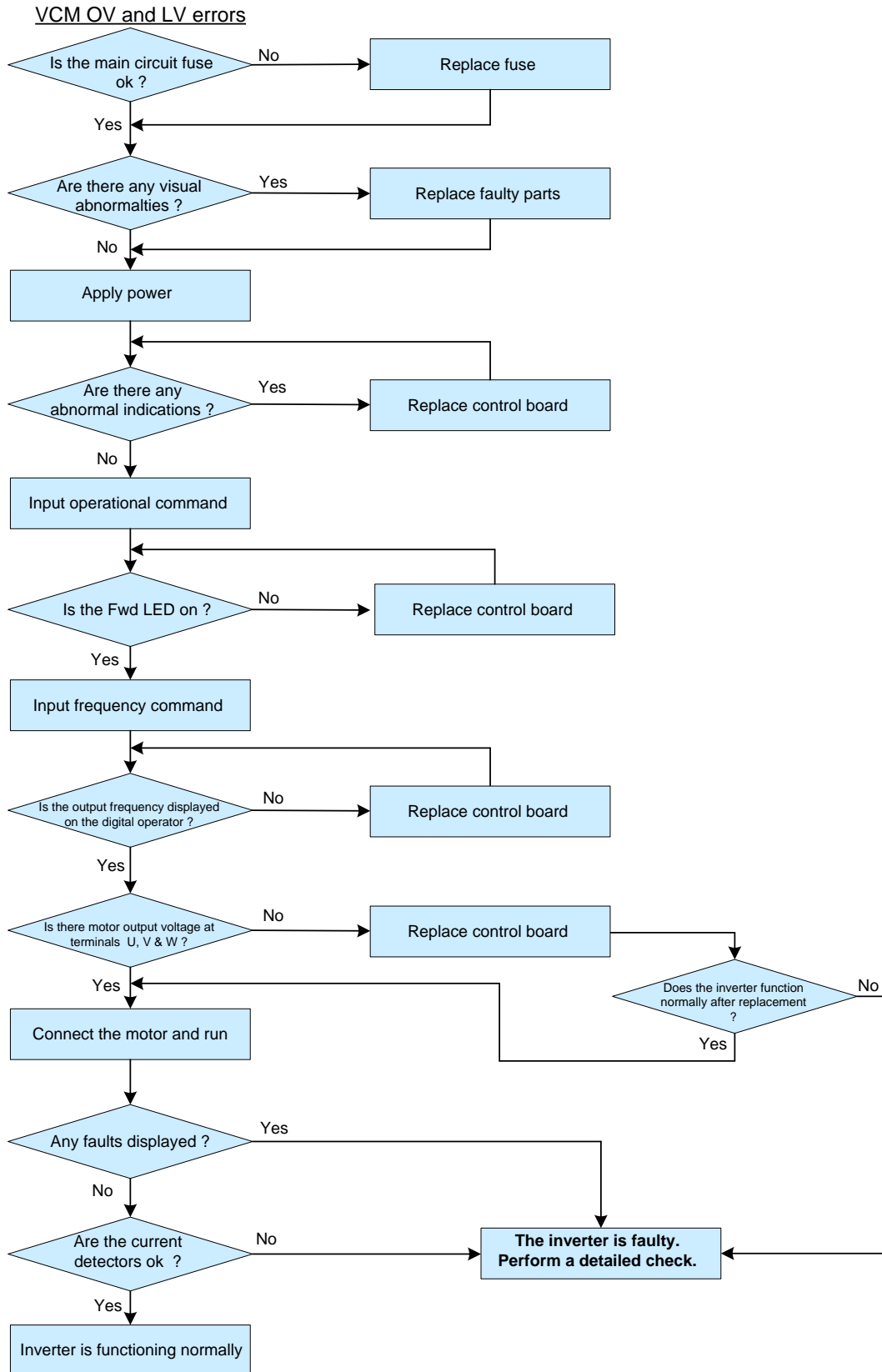

Fig. 22.3 OV and LV Error Troubleshooting

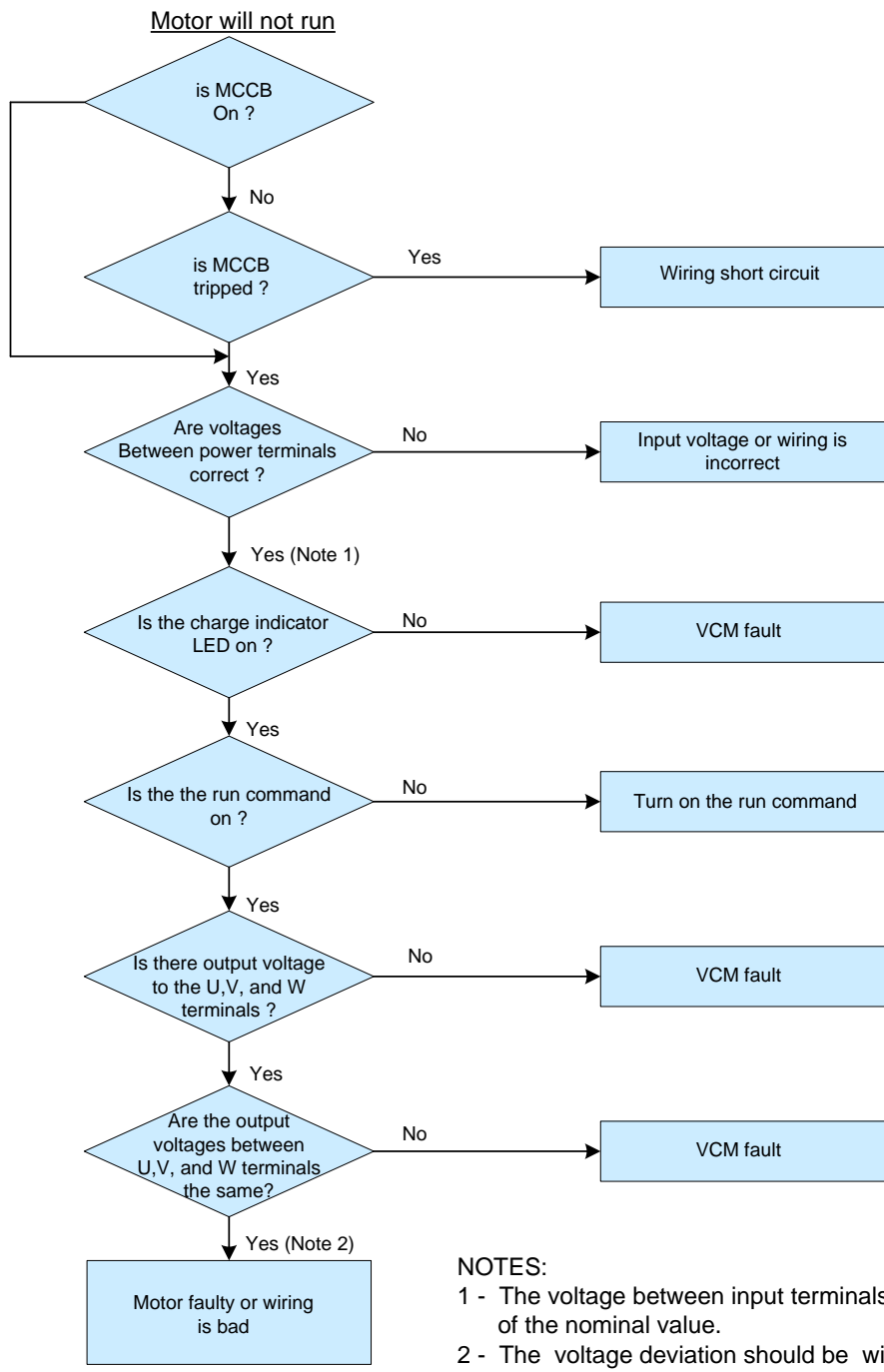

Fig. 22.4 Motor Will Not Run

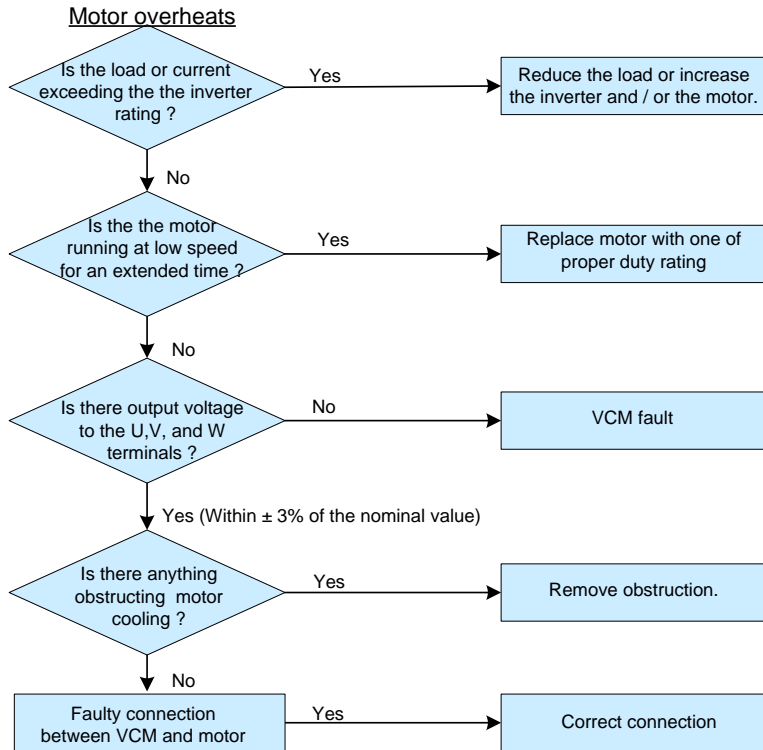

Fig. 22.5 Motor Overheating

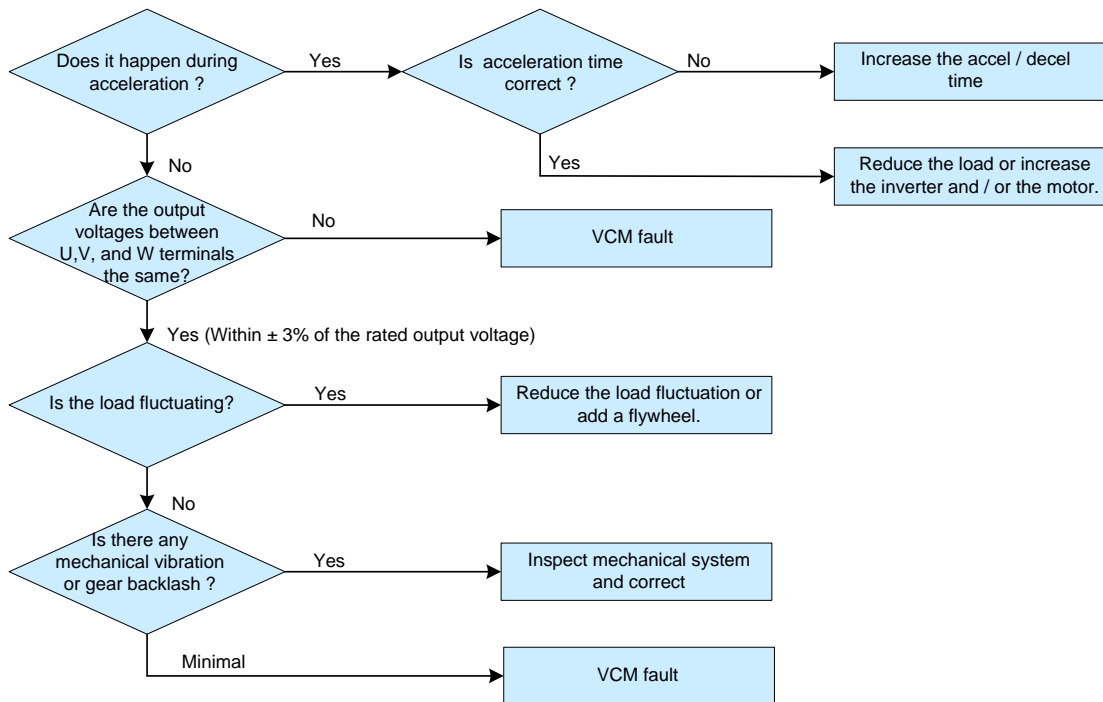

Fig. 22.6 Motor Instability

23.0 Routine periodic inspection

To ensure safe and secure operations, check and maintain the inverter and motor at regular intervals, the table below lists the suggested items to be checked on a periodic basis.

! DANGER

To prevent injury to personnel and damage to the equipment, wait 5 minutes after the “charge indicator” extinguishes before touching any parts.

Items	Details	Check		Methods	Criteria	Action
		Daily	Yearly			
Ambient conditions around the drive	Confirm that the temperature and humidity is within specification	x		Measure with thermometer and hygrometer	Temperature: -10 – 40°C (14-120°F) Humidity: Below 95% RH	Improve the ambient or relocate the drive.
	Are there flammable or corrosive materials in the vicinity?	x		Visual check	Keep area clear	
Installation and grounding of the inverter	Any excessive vibration from the machine ?	x		Visual, hearing check	No vibration	Secure hardware
	Is the ground bonding resistance correct?		x	Measure the resistance with a multi-tester	200V series: below 100Ω 400V series: below 10Ω	C grounding
Input power voltage	Is the voltage correct?	x		Measure the voltage with a multi-tester	Voltage must conform with the specifications	Correct input voltage
External terminals and internal mounting screws of the inverter	Are secure parts loose?		x	Visually check & Check with a screwdriver	Secure terminals and no rust present	Secure or return for repair
	Is the terminal base damaged?		x			
	Visual rust stains present?		x			
Internal wiring of the inverter	Any unusual bends or breaks?		x	Visual check	No abnormalities	Replace or return for repair
	Any damage of the wire insulation?		x			
Heat sink	Excessive dust or debris	x		Visual check	Clean surfaces	Clean up debris or dust
Printed circuit boards & power modules	Excessive dust or debris.		x	Visual check	Clean surfaces with no discoloration.	Clean or replace the circuit board or power modules
	Discolored, overheated, or burned parts		x			
Cooling fan	Unusual vibration and/or noise		x	Visual or hearing check	Clean surfaces	Replace the cooling fan
	Excessive dust or debris	x		Visual check		Clean fan
Capacitor	Any unusual odor or leakage	x		Visual check	No abnormalities	Replace capacitor or inverter

Appendix A - Specifications

AA.1 General Specifications

VCM Series		
	Control Mode	V/F or current vector control
Frequency Control	Range	0.1 - 400.0 Hz
	Starting control torque	150%/1Hz (current vector)
	Speed control range	50:1 (current vector)
	Speed control Accuracy	±0.5% (current vector)
	Setting resolution	Digital: 0.01Hz (Note 2), Analog: 0.06Hz/ 60Hz(10bits)
	Keypad setting	Set directly with ▲ ▼ keys or the VR on the keypad
	Display function	Four digital LED (or optional 2×16 LCD) and status indicator; displays frequency/ speed/ line speed/ DC voltage/ Output voltage/ Current/ rotation direction/ Inverter parameter/ Trouble log/ Program version
	External signal control	1. External potentiometer/ 0-10V/ 0-20mA; 10-0V/ 20-0mA 2. Performs up/down controls, speed control, or automatic procedure control with multifunctional contacts on the terminal block (TM2)
	Frequency limit function	Upper/lower frequency limits and three skip frequencies
General Control	PWM Carrier frequency	2 - 16 kHz
	V/F pattern	18 pre-configured patterns, 1 programmable
	Acc/Dec control	Two-stage Acc/Dec time (0.1 – 3,600 seconds) and two-stage S curves (refer to description in Sec.19)
	Multifunction analog output	6 functions (refer to parameters A103 & A104)
	Multifunction input	30 functions (refer to parameters A050 - A056)
	Multifunction output	16 functions (refer to parameters A105 & A106)
	Digital input signal	NPN (sink) / PNP (source)
	Other functions	Momentary power loss restart, speed search, overload detection, 8 preset speeds. Acc/Dec switch (2 stages), S curves, 3-wire control, PID control, torque boost, slip compensation, frequency upper/ lower limit, auto energy saving, Modbus communications, and auto restart.

Cont.

	Communication control	<ol style="list-style-type: none"> 1. RS232 or RS485 2. Multiple inverter networking (RS485 ONLY). 3. Baud rate, stop bit and parity can be set.
	Braking torque	20% - 100% for models with built-in braking transistor and braking resistor.
Environmental	Operation temperature	14-120°F (-10 - 50°C) (Note3)
	Storage temperature	- 4 to 140°F (-20 to 60°C)
	Humidity	0 – 95% Relative humidity (Non-condensing)
	Vibration	1G (9.8m/s ²)
	Altitude	< 3,281 ft. (1000m) (<i>De-rate for higher altitudes</i>)
	EMC	Complies with requirement EN 61800-3 (with optional filter).
	LVD	Complies with requirement EN 50178
	Enclosure	IP20 (NEMA with external enclosure)
	Safety level	UL 508C
Protective Functions	Overload	150 % for 1min
	Over voltage	230V class: DC voltage > 410V 460V class: DC voltage > 820V
	Under voltage	230V class: DC voltage < 190V 460V class: DC voltage < 380V
	Momentary power loss restart	For power interruptions of 15 ms or more and less than 2 sec., operation can be continued. (refer to parameters A013 & A014)
	Stall prevention	Stall prevention for acceleration/ deceleration/ operation.
	Short-circuit output terminal	Electronic circuit protection
	Grounding fault	Electronic circuit protection
	Other functions	Protection for overheating of heat sink, over torque detection, error contact control, reverse prohibit, prohibit for direct start after power up, and error recovery, and parameter lock out.

Note 1: 220V, 15HP and above **are not** CE compliant

Note 2: The frequency setting resolution above 100Hz is 0.1Hz when controlled by the keypad and 0.01 Hz when controlled by a computer (PC) or programmable controller (PLC).

Note 3: 14 -120°F (-10 - 50°C) Open chassis (without dustproof cover),
14 -104°F (-10 - 40°C) NEMA 1 (with dustproof cover).

AA.2 Product (Model) Specifications

Single Phase, 200-240V

VCM-2xx-1P	P5	01	02	03
Horsepower(HP)	0.5	1	2	3
Max applicable motor output (KW)	0.4	0.75	1.5	2.2
Rated output current(A)	3.1	4.5	7.5	10.5
Rated capacity(KVA)	1.2	1.7	2.9	4.0
Max. input voltage	Single Phase: 200 - 240V +10% -15%, 50/60Hz ± 5%			
Max. output voltage	Three Phase: 200 - 240V			
Input current(A)	8.5	12	16	23.9
Net weight Lb(KG)	2.87(1.3)	2.87(1.3)	3.31(1.8)	5.07(2.3)
Allowable momentary power loss time (second)	1.0	1.0	2.0	2.0

Three Phase, 200 – 240V

VCM-2xx-P/N	P5	01	02	03	05	07	10	15	20	25	30*	40*
Horsepower(HP)	0.5	1	2	3	5	7.5	10	15	20	25	30	40
Max applicable motor output (KW)	0.4	0.75	1.5	2.2	3.7	5.5	7.5	11	15	18.5	22	30
Rated output current(A)	3.1	4.5	7.5	10.5	17.5	26	35	48	64	80	96	130
Rated capacity(KVA)	1.2	1.7	2.9	4.0	6.7	9.9	13.3	20.6	27.4	34	41	54
Max. input voltage	Three phase: 200 - 240V +10% -15% , 50/60Hz ± 5%											
Max. output voltage	Three Phase: 200 - 240V											
Input current(A)	4.5	6.5	11	12.5	20.5	33	42	57	70	85	108	138
Net weight Lb(KG)	2.65 (1.2)	2.65 (1.2)	2.65 (1.2)	3.85 (1.75)	4.19 (1.9)	12.3 (5.6)	12.3 (5.6)	33.1 (15)	33.1 (15)	33.1 (15)	72.8 (33)	75.0 (34)
Allowable momentary power loss time (second)	1.0	1.0	2.0	2.0	2.0	2.0	2.0	2.0	2.0	2.0	2.0	2.0

Three Phase, 380 – 480V

VCM-4xx-P/N	01	02	03	05	07	10	15	20	25	30	40*	50*	60*	75*
Horsepower(HP)	1	2	3	5	7.5	10	15	20	25	30	40	50	60	75
Max applicable motor output (KW)	0.75	1.5	2.2	3.7	5.5	7.5	11	15	18.5	22	30	37	45	55
Rated output current(A)	2.3	3.8	5.2	8.8	13.0	17.5	25	32	40	48	64	80	96	128
Rated capacity(KVA)	1.7	2.9	4.0	6.7	9.9	13.3	19.1	27.4	34	41	54	68	82	110
<i>Cont.</i>														

Three Phase, 380 – 480V I cont.														
Max. input voltage	Three Phase:380 - 480V +10% -15%, 50/60Hz ± 5%													
Max. output voltage	Three Phase: 380 - 480V													
Input current(A)	4.2	5.6	7.3	11.6	17	23	31	38	48	56	75	92	112	142
Net weight Lb(KG)	2.87 (1.3)	2.87 (1.3)	3.31 (2.2)	3.31 (2.2)	12.3 (6.6)	12.3 (6.6)	12.3 (6.6)	33.1 (15)	33.1 (15)	33.1 (15)	72.8 (33)	72.8 (33)	110 (50)	110 (50)
Allowable momentary power loss time (second)	1.0	1.0	2.0	2.0	2.0	2.0	2.0	2.0	2.0	2.0	2.0	2.0	2.0	2.0

**Note: DC Reactor built-in (230V: 30 - 40 HP and 440V: 40 – 75 HP)*

NOTES:

Appendix B - VCM Motor Internal Parameter List

Initial (Factory) setting of the motor internal parameters:

VCM Model	Motor Data Parameters									
	* A001 Rated Voltage Vac	A002 Rated Amps A	A003 Rated HP	A004 Rated Speed RPM	A005 Rated Freq. Hz	A168 Stator Resistance Ω	A169 Rotor Resistance Ω	A170 Equivalent Inductance mH	A171 Magnetizing Current Amps (AC)	A172 Iron Loss Conductance gm
2P5	230	1.8	0.5	1710	60	200	200	800	7200	0
201		3.4	1.0	1680		380	300			
401	460	1.6				2.0	300			
202	230	6.1	1720	300			280			
402	460	3.0	1715							
203	230	8.7	3.0	1735		280	240			
403	460	4.3								
205	230	13.5	5.0	1745		260	200			
405	460	6.8								
207	230	20.0	7.5	1750		240	160			
407	460	13.0								
210	230	26	10	1750		220	150			
410	460	12.5								
215	230	37	15	1760		200	140			
415	460	18.5								
220	230	50	20	1760		180	130	4100	205	
420	460	25								
225	230	63	25	1750						
425	460	36								
230	230	73	30	1750						
430	460	36.5								
240	230	98	40	1750						
440	460	49								
450		72	50	1760						
460		73	60							
475		108	75							

*The values shown for parameter A001 (Rated Voltage) is for 60 Hz. For 50 Hz., the rated voltage for the (200V Class) is 220V and for the (400V Class) is 440V.

- Initially the drive HP code, parameter A175, sets the factory default motor internal parameters (A168 – A172) as shown in the above table. These parameters are used for *Vector Control Mode* only (A000 = 0000 or 0001) and are not used in *V/F Control Mode* (A000 = 0002).
- When an auto-tune is performed (A006 = 0001), the motor internal parameters (A168 - 172) will be automatically updated to the values measured during the auto tune process. These values are maintained when a factory reset is performed.
- If the motor is replaced, the auto-tune procedure must once again be carried out. If the parameters (A168 – 172) are known, they may be entered directly without auto-tuning.
- The motor parameters (A168 to A172) will be modified to the factory setting under any operation mode, when changing the Drive Horsepower code (A175).

Appendix C – Table C - VCM Envelope Dimensions and Weights vs Model No.

Model No.	Approx. Wt. Lbs. / Kg	Frame Size	Envelope Dimensions - Inches / (mm)						
			H	W	D	a	b	c	m
230V 1 Phase Input									
VCM – 2P5 – 1P	3 / 1.36	1	6.42	3.54	5.79	5.9	3.07	0.28	0.22
VCM – 201 – 1P			(163)	(90)	(147)	(150)	(78)	(7)	(5.5)
VCM – 202 – 1P	4 / 1.81	2	7.36	5.04	5.83	6.71	4.51	0.28	0.22
VCM – 203 – 1P	5 / 2.27		(187.1)	(128)	(148)	(170.5)	(114.6)	(7)	(5.5)
230V 3-Phase Input									
VCM – 2P5 - P	3 / 1.36	1	6.42	3.54	5.79	5.9	3.07	0.28	0.22
VCM – 201 - P			(163)	(90)	(147)	(150)	(78)	(7)	(5.5)
VCM – 202 - P									
VCM – 203 - P	4 / 1.81	2	7.36	5.04	5.83	6.71	4.51	0.28	0.22
VCM – 205 - P	5 / 2.27		(187.1)	(128)	(148)	(170.5)	(114.6)	(7)	(5.5)
VCM – 207 - P	13 / 5.9	3	10.24	7.32	7.68	9.61	6.81	X	0.22
VCM – 210 - P			(260)	(186)	(195)	(244)	(173)		(5.5)
VCM – 215 - N	27 /	4	14.2	10.4	9.7	13.4	9.6	X	0.3
VCM – 220 - N	12.25								
VCM – 225 - N	29 / 13.15								
VCM – 230 - N	67.0	5	25.5	10.7	10.4	20.9	8.3	X	0.4
VCM – 240 - N	(30.9)		(647.6)	(272.6)	(263.5)	(530)	(210)		(10)
460V 3-Phase Input									
VCM – 401 – P	3 / 1.36	1	6.42	3.54	5.79	5.9	3.07	0.28	0.22
VCM – 402 – P			(163)	(90)	(147)	(150)	(78)	(7)	(5.5)
VCM – 403 – P	4 / 1.81	2	7.36	5.04	5.83	6.71	4.51	0.28	0.22
VCM – 405 – P			(187.1)	(128)	(148)	(170.5)	(114.6)	(7)	(5.5)
VCM – 407 – P	13 / 5.9	3	10.24	7.32	7.68	9.61	6.81	X	0.22
VCM – 410 – P									
VCM – 415 – P									
VCM – 420 – N	27 /	4	14.2	10.4	9.7	13.4	9.6	X	0.3
VCM – 425 – N	12.25								
VCM – 430 – N	29 / 13.15								
VCM – 440 – N	67 /	5	25.5	10.7	10.4	20.9	8.3	X	0.4
VCM – 450 – N	30.89								
VCM – 460 – N	102 /	6	29.6	12.3	10.5	24.8	9.8	X	0.4
VCM – 475 – N	46.27								

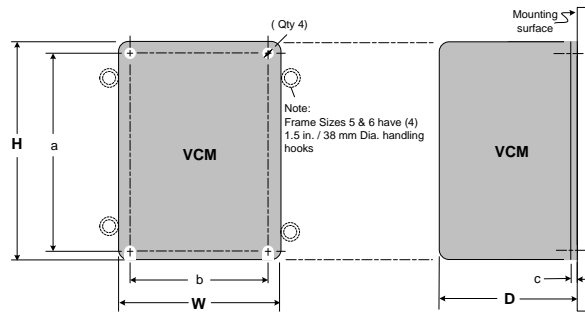

Fig. AC.1 VCM Envelope Dimensional Information

Appendix D – VCM Cover Removal Procedure for Various Frame Sizes

The following Fig.'s show the cover removal for the various VCM frame sizes 1 thru 6. The Models correlating to the frame sizes are covered in Appendix C.

! DANGER

Do not Remove any covers while power is supplied to the equipment as lethal voltages are present. Wait at least 5 min. after disconnecting power and ensure the charge indicating lamp is off.

Cover Removal Procedure

- 1 – Loosen the mounting screw completely.
- 2 – Push in on the sides of the cover at points "A" and lift and remove the cover.

Cover Replacement

- 1 – Set the cover and snap into place and secure with the mounting screw.

Note: If it is desired to remove the Digital Operator, grip it at the the points shown and pull it *straight* out. (The Operator has a connector that plugs directly into to the chassis.) To replace the Digital Operator insert it by carefully lining up the connector and pushing *straight* in.

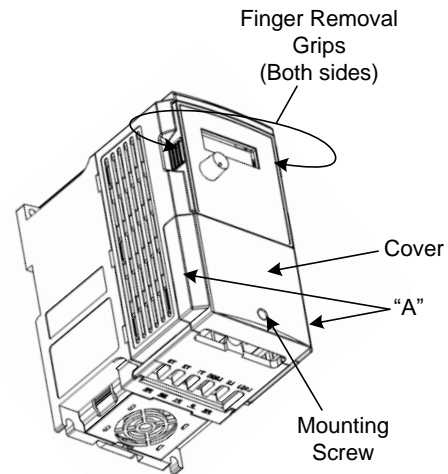

Fig. AD.1 Cover Removal for VCM Frame Sizes 1 & 2

Cover Removal Procedure

- 1 – Loosen the two mounting screws completely.
- 2 – Push in on the sides of the cover at points "A" and lift and remove the cover.

Cover Replacement

- 1 – Set the cover and snap into place and secure with the two mounting screws.

Note: If it is desired to remove the Digital Operator, grip it at the the points shown and pull it *straight* out. (The Operator has a connector that plugs directly into to the chassis.) To replace the Digital Operator insert it by carefully lining up the connector and pushing *straight* in.

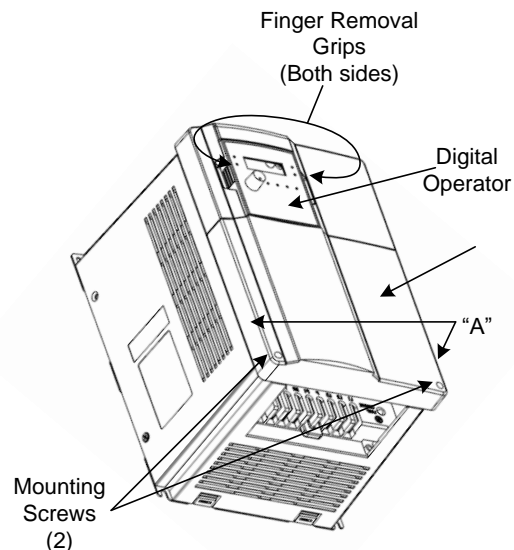

Fig. AD.2 Cover Removal for VCM Frame Size 3

Cover Removal Procedure

- 1 – First remove the Digital Operator by gripping at the points shown and pulling *straight* out. (The Operator has a connector that plugs directly into the chassis.)
- 2 – Loosen the four mounting screws and lift off the cover.

Cover Replacement

- 1 – Set the cover in place and secure with the four mounting screws.
- 2 – Next insert the Digital Operator by carefully lining up the connector and pushing *straight* in.

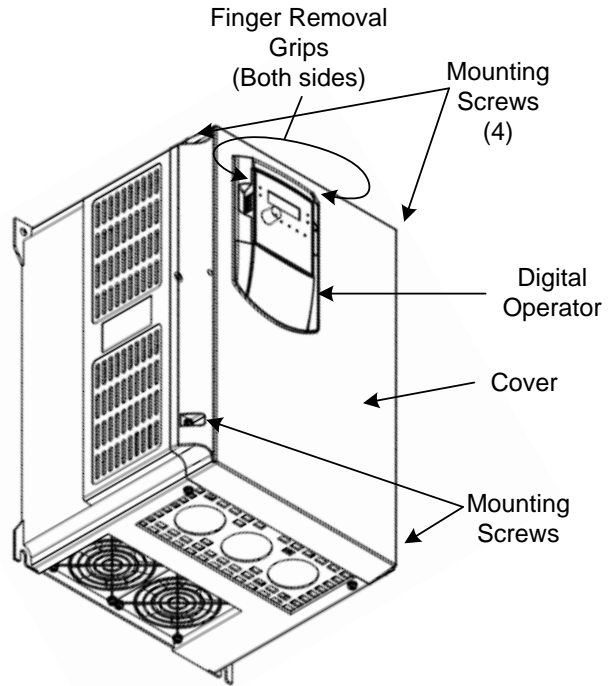

Fig. AD.3 Cover Removal for VCM Frame Size 4

Cover Removal Procedure

- 1 – First remove the Digital Operator by gripping at the points shown and pulling *straight* out. (The Operator has a connector that plugs directly into the chassis.)
- 2 – Loosen both mounting screws “A” and back out but do not remove.
- 3 – Loosen and remove both mounting screws “B”.
- 4 – Slide the main cover up and lift off.
- 5 – The conduit box cover if needed may be removed in essentially the same way.

Cover Replacement

- 1 – Slide the main cover screw slots over screws “A” and set in place.
- 2 – Insert and tighten screws “B” and then tighten screws “A”.
- 3 – Next insert the Digital Operator by carefully lining up the connector and pushing *straight* in.
- 4 – Replace the conduit box cover if it was removed.

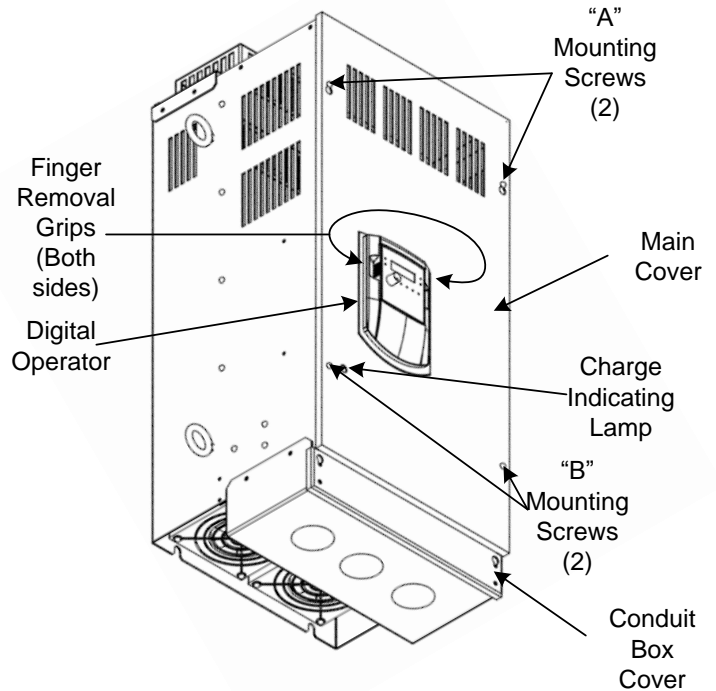

Fig. AD.4 Cover Removal for VCM Frame Sizes 5 & 6

Appendix E – Inverter Parameter Setting List

Customer:						VCM Model No.					
Site:						Equipment:					
b		A									
Para	Setting	Para	Setting	Para	Setting	Para	Setting	Para	Setting	Para	Setting
b000		A000		A037		A074		A111		A148	
b001		A001		A038		A075		A112		A149	
b002		A002		A039		A076		A113		A150	
b003		A003		A040		A077		A114		A151	
b004		A004		A041		A078		A115		A152	
b005		A005		A042		A079		A116		A153	
b006		A006		A043		A080		A117		A154	
b007		A007		A044		A081		A118		A155	
b008		A008		A045		A082		A119		A156	
b009		A009		A046		A083		A120		A157	
b010		A010		A047		A084		A121		A158	
b011		A011		A048		A085		A122		A159	
b012		A012		A049		A086		A123		A160	
b013		A013		A050		A087		A124		A161	
b014		A014		A051		A088		A125		A162	
b015		A015		A052		A089		A126		A163	
b016		A016		A053		A090		A127		A164	
		A017		A054		A091		A128		A165	
		A018		A055		A092		A129		A166	
		A019		A056		A093		A130		A167	
		A020		A057		A094		A131		A168	
		A021		A058		A095		A132		A169	
		A022		A059		A096		A133		A170	
		A023		A060		A097		A134		A171	
		A024		A061		A098		A135		A172	
		A025		A062		A099		A136		A173	
		A026		A063		A100		A137		A174	
		A027		A064		A101		A138		A175	
		A028		A065		A102		A139		A176	
		A029		A066		A103		A140		A177	
		A030		A067		A104		A141		A178	
		A031		A068		A105		A142		A179	
		A032		A069		A106		A143		A180	
		A033		A070		A107		A144		A181	
		A034		A071		A108		A145			
		A035		A072		A109		A146			
		A036		A073		A110		A147			

Appendix F – Version 1.3 Changes

Overview

The changes to the VCM inverter for firmware Version 1.3 consist of some hardware and **A** (advanced) parameter additions and modifications. Basically for models in the 3 – 75 HP range, the control terminal digital and analog grounds were isolated from each other and the **S6/AI2** multifunctional input terminal was separated into two terminals where **S6** is exclusively a digital input and **AI2** is exclusively an analog input. Also some **A** (advanced) parameters were added and / or modified. The following will describe the details of the changes

Hardware Changes:

Models in the 3 – 75 HP range:

Prior to Version 1.3, control terminal **S6/AI2** served as a multi function terminal and could be programmed to be a digital or analog input and control terminal **COM** was the common connection for both analog and digital inputs. In Version 1.3 separate control terminals **AI2** (analog input 2) and **AGND** (analog ground) were added to the VCM Models covering the 3 – 75 HP range. Also terminal **S6** is a digital input only. (See Fig. 10.2.3, **Sec. 10.0** Control Terminals, and General Wiring Diagram **6.0**)

Models in the 1 - 2 HP range:

There are no hardware changes in Version 1.3 for models in the 1-2 HP range. As in previous versions control terminal **S6/AI2** is a multi function terminal and can be programmed to be a digital or analog input. This is also applicable to 3 – 75 HP Models prior to Version 1.3. (See **Sec. 10.0** Control Terminals and General Wiring Diagram **5.0**)

Parameter Changes: (See Sec. 19.0 for parameter details)

Models in the 3 – 75 HP range:

Parameter A049 was added.

VER.	Parameter	LCD Display	Description	Range	Factory Setting
1.3	A049	AI2 Function	AI2 Function Set	20 / 21 / 22	20

Parameters A055 – A056, A097, and A0154 were modified.

VER.	Parameter	LCD Display	Description	Range	Factory Setting
1.3	A050-A055	S1 – S6 Term Sel	Multifunctional Input Term. S1 – S6	0008: Base Block A Contact 0020: PID Feedback Signal AI2 (terminal AI2)	0023
	A056	AIN Term Sel	Multifunctional Input Term. AIN	0021: AI2 Bias Signal 1 Input (terminal AI2) 0022: AI2 Bias Signal 2 Input (terminal AI2)	See Sec. 19.0
Prior	A050-A055	S1 – S6 Term Sel	Multifunctional Input Term. S1 – S6	0008: Base Block 0020: PID Feedback Signal AI2 (terminal S6)	0023
	A056	AIN Term Sel	Multifunctional Input Term. AIN	0021: AI2 Bias Signal 1 Input (terminal S6) 0022: AI2 Bias Signal 2 Input (terminal S6)	See Sec. 19.0

Cont.

VER.	Parameter	LCD Display	Description	Range	Factory Setting
1.3	A097	AI2 Gain	AI2 Gain (%) AI2	0 - 200	100
Prior	A097	AI2 Gain	AI2 Gain (%) S6	0 - 200	100

VER.	Parameter	LCD Display	Description	Range	Factory Setting
1.3	A154	AIN AI2 Source	AIN or AI2 Source Signal	0000: AIN = 0 -10V or 0 - 20mA AI2 = 0 -10V or 0 - 20mA 0001: AIN = 0 -10V or 0 - 20mA AI2 = 2 -10V or 4 - 20 mA 0002: AIN = 2 -10V or 4 - 20 mA AI2 = 0 -10V or 0 - 20mA 0003: AIN = 2 -10V or 4 - 20 mA AI2 = 2 -10V or 4 - 20 mA	0000
Prior	A154	PID Comm. Source	PID Feedback signal	0000: 0-10V or 0-20mA 0001: 2-10V or 4-20mA	0000

Parameters A161 and A162 were added and selections 0025 and 0026 were added for parameters A050 –A055.

VER.	Parameter	LCD Display	Description	Range	Factory Setting
1.3	A161	Comm Error Operation Sel	Communications time-out operation selection	0000: Deceleration to stop. (b008: Deceleration time 1) 0001: Coast to stop. 0002: Deceleration to stop. (A026: Deceleration time 2) 0003: Continue operating.	0000
	A162	Comm Error detection time.	Communications time-out detection time.	00.0 - 25.5 Sec.	00.00
	A050-A056	S1 – S6 Term Sel	Multifunctional Input Term. S1 – S6	0025: Emergency Stop B Contact 0026: Base Block B Contact	See Sec. 19.0

Important – Throughout this manual, multifunctional terminal S6/AI2 is to be substituted where terminal AI2 and S6 is referenced separately for 1 - 2 HP models and 3 – 75 HP models prior to version 1.3 unless otherwise noted.



MOTORTRONICS™
Solid State AC Motor Controls