



MOTORTRONICS™

Solid State AC Motor Controls

VMX

Series

Compact Soft Starter

Ratings 18 - 1250A

BASIC INSTALLATION AND QUICK STARTUP GUIDE



VMX-QSG604132MN - 03/15/12
FIRMWARE VERSION 4.25

Table of Contents

Quick Start “Minimum Settings” Guide	4
Chapter 1: Introduction	5
General Description, Sizes and Ratings	5
Dimensions and Weights	6
Chapter 2: Installation	8
Receiving, Unpacking and Inspection	8
SERVICE WARNING!	8
Mounting Clearances and Cleaning	8
Electrical Connections	9
Power Connections	9
Bypass Contactor	9
Power Factor Correction Capacitors	9
Power Terminals	10
Remote Keypad Mounting	10
Control Connections	11
AC Control Power Supply Connection	11
Control Fusing	12
Three-Wire Control Connection	12
Seal In Contact	12
Two Wire Control: Relay / PLC Connection	12
Interlock Connection	12
PTC Thermistor Input	13
Fault Signal	13
Dual Ramp and Jog Features	14
Jog / Remote Command	14
Output (Auxiliary) Relay Contacts	15
Bypass Contactor Control	15
Chapter 3: Sequence of Operation	17
Starting and Stopping	17

Table of Contents - Continued

Chapter 4: Programming 18

 Introduction 18

 Digital Interface..... 18

 Display and Program Modes 18

 Program Function List 22

 Auxiliary Output Relay Settings..... 27

 Fault Mode..... 28

Chapter 5: Motor Overload Protection 29

 Solid State Overload Protection 29

 Overload Class Trip Curves 31

Quick Startup “Minimum Settings” Guide

Your new **VMX Series** Soft Starter is factory preset for a wide variety of applications and often can be used with minimal adjustment.

Try these initial factory presets first and then adjust or enable the more advanced features to meet your specific starting needs.

Three Step Process:

1. **Connect L1, L2, L3 to power lines and T1, T2, T3 to motor (see page 9)**
2. **Connect control wires and control power (see pages 11-15)**
3. **Program motor FLA (see page 18).**

Your VMX unit is ready to start!

Start-up Check List

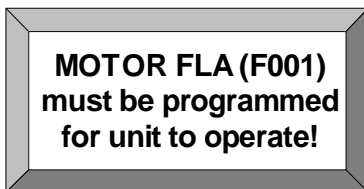

- Supply voltage matches the rated supply voltage of the unit.
- Horsepower and current ratings of the motor and unit match or the unit is higher rating.
- Initial ramp time and torque adjustments have been checked.
- Power lines are attached to the unit input terminals marked L1, L2 and L3 (R, S, T).
- Motor leads are connected to the lower terminals marked T1, T2, and T3 (U, V, W).
- Appropriate control power is applied
- Control connections have been made.
- “Power on” light located on the front of the unit turns on when control power is applied.
- Four seven-segment LED readouts are visible.
- The motor’s FLA has been programmed in function F001.
- The thermal overload is properly set. (Use F003 and F004 to set OL Class.)
- The motor area and equipment are clear of people and parts before start-up.

This list provides only the bare minimum settings necessary to make your motor run, and provides basic levels of motor protection. Safety precautions, listed further on in this manual, must always be followed. Ramp setting adjustments and additional protection features may be necessary. Please read further for additional details.

Chapter 1 - Introduction

General Description

The **VMX Series** is a digitally programmable solid state reduced voltage soft starter using a six SCR design. It features a voltage/current ramp for smooth load acceleration. The SCRs are sized to withstand starting currents of 350% for 30 seconds and up to 600% for 10 seconds for applications typical to NEMA / UL Class 10 overload trip curves. The **VMX Series** features smooth stepless ramp control, which reduces motor inrush current and excessive wear on the mechanical drive train components. The **VMX Series** includes a programmable keypad for setting operating parameters for the ideal starting cycle and protection features, plus easy to understand diagnostic LEDs. Starting torque, ramp time, current limit, dual ramp, and Decel control are standard features on the **VMX Series**. The **VMX Series** includes solid state electronic overload protection in addition to numerous other protective features. It requires 120VAC (220VAC optional) control power and uses dry contact inputs for Start / Stop control. Programmable auxiliary contacts and provisions for interlocking are also included.

Sizes and Ratings

Model Number	Current Range
	Min. - Max.
VMX-18-BP	9 - 18
VMX-28-BP	14 - 28
VMX-39-BP	19 - 39
VMX-48-BP	24 - 48
VMX-62-BP	36 - 62
VMX-78-BP	39 - 78
VMX-92-BP	46 - 92
VMX-112-BP	56 - 112
VMX-150-BP	75 - 150
VMX-160-BP	80 - 160
VMX-210-BP	105 - 210
VMX-275-BP	137 - 275
VMX-361-BP	180 - 361
VMX-450-BP	225 - 450
VMX-550-BP	275 - 550
VMX-600-BP	300 - 600
VMX-862-BP	431 - 862
VMX-900-BP	450 - 900
VMX-1000-BP	503 - 1006
VMX-1250-BP	625 - 1250

The Motortronics **VMX Series** starters are **current rated** controllers. Max. Amp ratings are for continuous duty and must not be exceeded. Always check the motor nameplate FLA and Service Factor (if used) to ensure proper sizing. Each size has an adjustable range of current from 50% to 100% of the Max Amp rating. Table 1 to the left shows the Current Ratings available.

Table 1: VMX Series selection

Dimensions and Weights

Enclosure	Model Number	Overall			Mounting			Weight lbs (kg)
		A Inches (mm)	B Inches (mm)	C Inches (mm)	D Inches (mm)	E Inches (mm)	F Inches (mm)	
Panel (open) with integral bypass contactor	VMX-18-BP through VMX-48-BP	9.06 (230)	8.00 (203)	6.68 (169.7)	8.06 (204.7)	7.00 (177.8)	0.22 (5.6)	13 (5.9)
	VMX-62-BP through VMX-112-BP	14.00 (355.6)	8.00 (203)	6.68 (169.7)	13.25 (336.6)	6.75 (171.5)	0.28 (7.1)	23 (10.4)
	VMX-150-BP and VMX-160-BP	19.21 (487.9)	8.00 (203)	6.68 (169.7)	18.25 (463.6)	6.75 (171.5)	0.28 (7.1)	35 (15.9)
	VMX -210-BP and VMX-275-BP	28.50 (723.9)	12.5 (317.5)	9.03 (229.4)	27.38 (695.5)	10.75 (273.1)	0.40 (10.2)	90 (40.9)
	VMX-361-BP and VMX-450-BP	29.29 (744)	12.5 (317.5)	9.03 (229.4)	27.38 (695.5)	10.75 (273.1)	0.40 (10.2)	105 (47.7)
	VMX-550-BP through VMX -600-BP	30.98 (786.9)	12.5 (317.5)	9.05 (229.9)	27.38 (695.5)	10.75 (273.1)	0.40 (10.2)	120 (55)
	VMX-862-BP through VMX-900-BP	44.25 (1124)	25.5 (647.7)	11.86 (301.3)	43 (1092.2)	23 (584.2)	0.40 (10.2)	Contact Factory
	VMX-1006-BP through VMX -1250-BP	46.56 (1182.6)	28.20 (647.7)	13.00 (716.3)	42.75 (1085.9)	23.24 (590.3)	0.50 (12.7)	Contact Factory

Table 2: VMX Dimensions (subject to change)

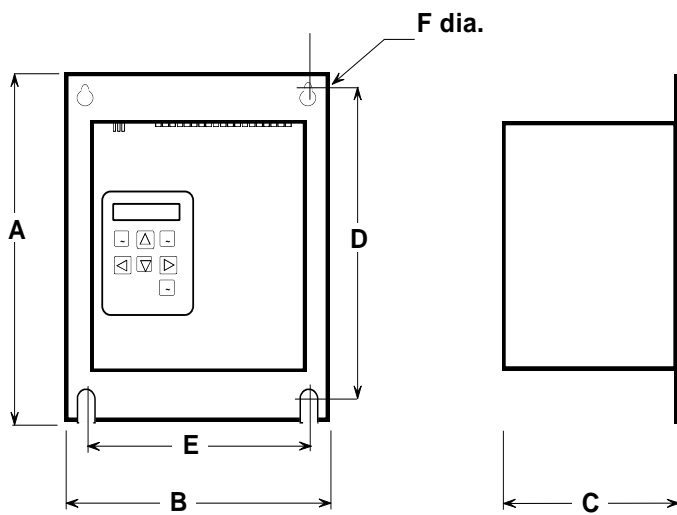

Figure 1: VMX Dimensions

Chapter 2 – Installation

Receiving and Unpacking

Upon receipt of the product, you should immediately do the following:

- Carefully unpack the unit from the shipping carton and inspect it for shipping damage (if damaged, notify the freight carrier and file a claim within 15 days of receipt).
- Verify that the model number on the unit matches your purchase order.
- Confirm that the ratings sticker on the unit matches or is greater than the motor's nameplate Full Load Current (FLC or FLA) rating and Service Factor (if used).

Choosing a Location

Proper location of the **VMX Series** is necessary to achieve specified performance and normal operation lifetime. The **VMX Series** should always be installed in an area where the following conditions exist:

Ambient operating temperature:

- Panel (open chassis) unit: 0 to 50°C (32 to 122°F)
- Enclosed unit: 0 to 40°C (32 to 104°F)

Protected from rain, moisture and dust.

Enclosed units should not be exposed to direct sun.

- Humidity: 5 to 95% non-condensing
- Free from metallic particles, conductive dust and corrosive gas
- Free from excessive vibration (below 0.5G)

Open panel units must be mounted in the appropriate type of enclosure. Enclosure size and type must be suitable to dissipate heat generated by the soft starter and any other components mounted inside with it.

Units with –BP Bypass Contactors produce less heat than units without. Throughout all sizes, maximum heat dissipation of the VMX...-BP Series electronics, contactor coils and fans is less than 50W.

NOTE: This does not include heat generated by cables, lugs or busbars.

Initial Unit Inspection

Make a complete visual check of the unit for damage that may have occurred during shipping and handling. Do not attempt to continue installation or start up the unit if it is damaged.

Check for loose mechanical assemblies or broken wires which may have occurred during transportation or handling. Loose electrical connections will increase resistance and cause the unit to function improperly.

Mounting and Cleaning

When drilling or punching holes in the enclosure, cover the electrical assembly to prevent metal filings from becoming lodged in areas which can cause clearance reduction or actually short out electronics. After work is complete, thoroughly clean, vacuum the area, and re-inspect the unit for foreign material.

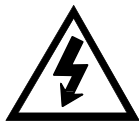

SERVICE WARNING!

Do not service equipment with voltage applied! The unit can be the source of fatal electrical shocks! To avoid shock hazard, disconnect main power and control power before working on the unit. Warning labels must be attached to terminals, enclosure and control panel to meet local codes. Use Lock Out tags such as the one shown when servicing equipment.

Clearances

Make sure there is sufficient clearance all around the unit for cooling, wiring and maintenance purposes. To conserve panel space, the **VMX Series – BP** models were designed for close vertical clearances of only 1 inch (25mm) on either side. A minimum horizontal clearance of 4" (100 mm) on the top and bottom is necessary to maximize effective airflow and cooling. Also the unit must be installed with its heat sink ribs oriented vertically and running parallel to the mounting surface. Keep in mind that these are minimums. Wiring may require more clearance, particularly on the bottom.

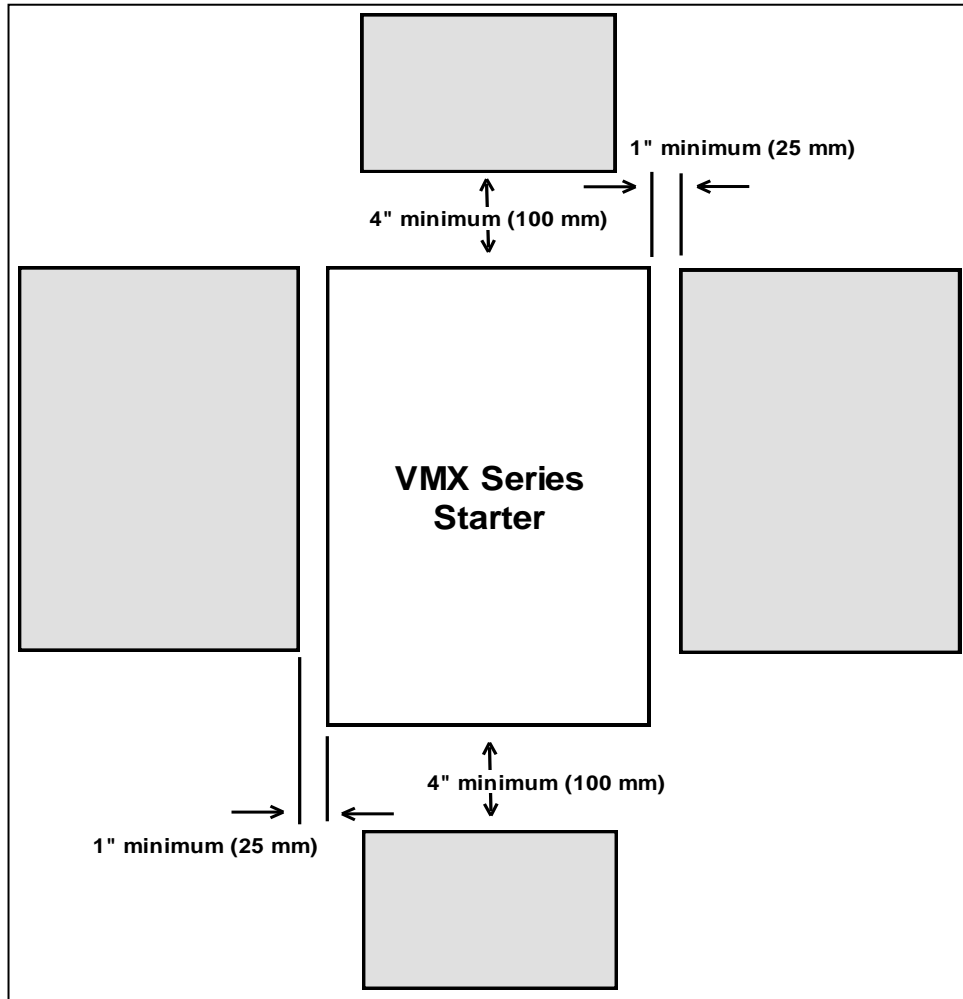

Figure 2: VMX minimum mounting clearances

Cleaning:



WARNING!
Remove all sources of power before cleaning the unit.

In dirty or contaminated atmospheres, the unit should be cleaned on a regular basis to ensure proper cooling. Do not use any chemicals to clean the unit. To remove surface dust use clean, dry compressed air only, 80 to 100 psi. A three inch, high quality, dry paintbrush is helpful to loosen up the dust prior to using compressed air on the unit. Do not use wire brushes or other conductive cleaning materials.

Electrical Connections

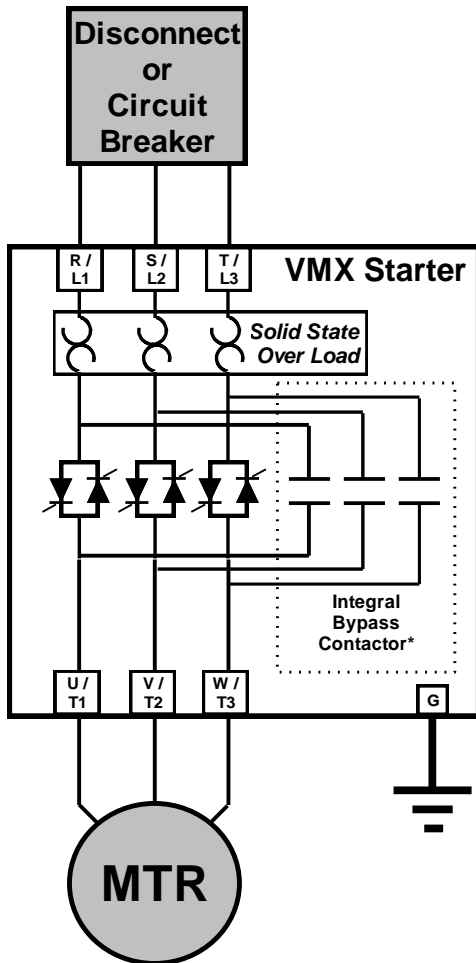

Figure 3:
VMX Power Connections

Power Connections

Referring to local code standards for wire sizing and length, connect power conductors to the unit input terminals marked L1, L2, L3 (R, S, T for IEC users). Connection points are bus tabs with pre-drilled holes (see section 2 of the Advanced Installation, Operation and Programming Manual). Use appropriate compression or mechanical lugs for termination to these bus tabs. Avoid routing power wires over the control board or display. Connect the motor leads to the unit terminals marked T1, T2, T3 (U, V, W for IEC users). If control power is present, but line power is disconnected from L1, L2, L3, the display will show **[n3PH]** indicating “no 3 Phase”.

Caution!



Never interchange input and output connections to the unit. This could cause excessive voltage in the control logic circuit and may damage the unit.

Bypass Contactor

Bypass Contactors are integral (built-in) on all VMX...-BP (panel mount), and all VMX...-E (NEMA 12 enclosed) versions. See Section 3.2.1. and 4.2.5 of the Advanced Installation, Operation and Programming Manual for more details on contactor control and overload protection details.

Power Factor Correction Capacitors

Power factor correction capacitors can be connected to motors controlled by **VMX Series** starters, however they must be off-line during ramping. Connect PFC capacitors to the Line side of the starter with a separate capacitor control contactor.



WARNING!

Never connect power factor correction capacitors on the load side of the unit. The SCRs will be seriously damaged if capacitors are located on the load side.

Grounding

Connect the ground cable to the ground terminal as labeled on the unit. Refer to the National Electrical Code or your local Code for the proper ground wire sizing and be sure that the ground connector is connected to earth ground. In ungrounded systems, it is not necessary to connect a ground to the unit however local codes should always be consulted.

Power Terminals:

Connection points are bus tabs with pre-drilled holes (see below). Use appropriate compression or mechanical lugs for termination to these bus tabs.

Suggested wire sizes and tightening torques for factory-supplied connectors for conductors rated for 75°C are shown in the chart below. Always consult local codes and industry standard practices for proper wires sizes to accommodate voltage drop and ambient conditions.

Model Number	Current Range Min.- Max.	Suggested Wire Size AWG	Tightening Torque in.-lbs.	Screw / Bolt Size	Tightening Torque Nm	Suggested Wire Size ISImm ²
VMX-18-BP	9 - 18	12	35	1 x M5 (included)	4	6
VMX-28-BP	14 - 28	10				10
VMX-39-BP	19 - 39	8				16
VMX-48-BP	24 - 48	6				16
VMX-62-BP	36 - 62	4	45	1 x M8 (included)	5	25
VMX-78-BP	39 - 78	3				35
VMX-92-BP	46 - 92	2				35
VMX-112-BP	56 - 112	2				50
VMX-150-BP	75 - 150	0	80	1 x M8 (included)	9	70
VMX-160-BP	80 - 160	2/0				70
VMX-210-BP	105 - 210	4/0	200	1 x 0.38" hole (M10) for User supplied lugs	15	120
VMX-275-BP	137 - 275	300 kCMIL				150
VMX-361-BP	180 - 361	500 kCMIL				300
VMX-450-BP	225 - 450	2 x 250 kCMIL				2 x 150
VMX-550-BP	275 - 550	2 x 250 kCMIL				2 x 150
VMX-600-BP	300 – 600	TBD	TBD	TBD	TBD	TBD
VMX-862-BP	431 – 862	TBD	TBD	TBD	TBD	TBD
VMX-900-BP	450 – 900	TBD	TBD	TBD	TBD	TBD
VMX-1006-BP	503 - 1006	TBD	TBD	TBD	TBD	TBD
VMX-1250-BP	625 - 1250	TBD	TBD	TBD	TBD	TBD

Table 3: VMX Series Wire Ranges and Torque Specifications Note: TBD = To Be Determined at a later date

Remote Keypad Mounting

The keypad / operator interface unit can be remotely mounted up to 10' (3 meters) away from the starter, i.e. on the enclosure door. A remote mounting kit is necessary, which consists of an adaptor plate, a doorframe for NEMA 12 enclosures and a pre-assembled ribbon cable available in 1-meter length increments. Detailed assembly instructions and an enclosure cutout template are included with the kit. See Product Selection Guide for part numbers of the available kits.

Figure 4 Remote Keypad Mounting Kit Components

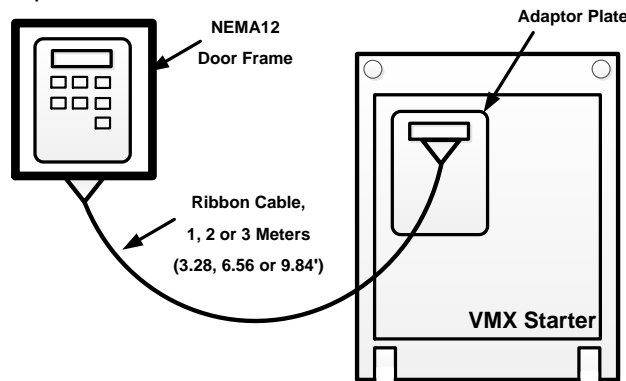

Control Connections

Control connections on the **VMX Series** starter are divided into 2 groups. With the unit oriented vertically, TB1 is a 12-point DC terminal block (on the left), and TB2 is a 10 point AC terminal block (on the right side). These are removable terminal blocks for ease of connection and servicing, and are provided with different spacing (pitch) between the header pins so they are not interchangeable. Following are descriptions of control connection points.

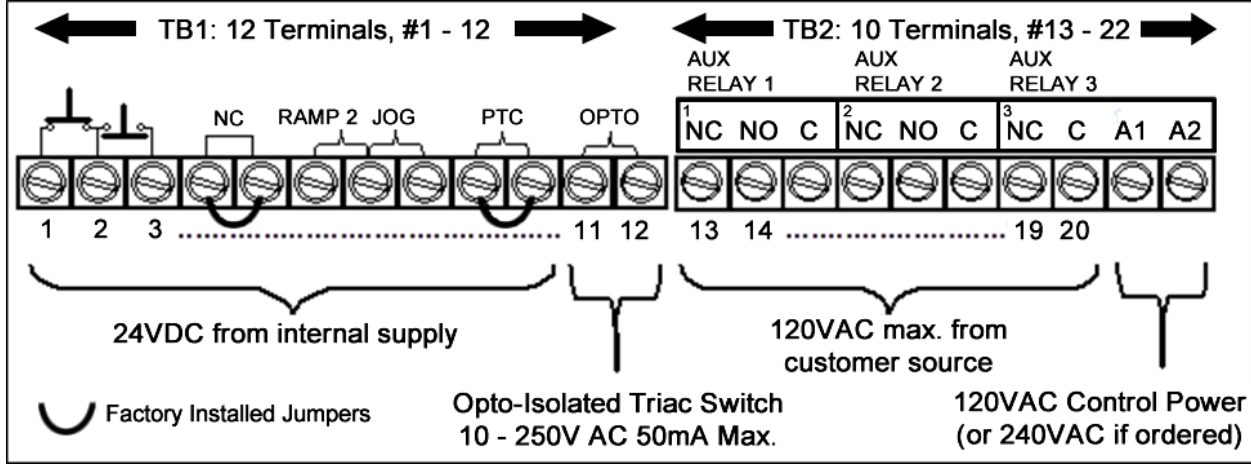

Figure 5.



Note:

Terminal numbers are shown on the side of the first and last terminal of each block. An additional 3 point terminal on the far left side is for serial communication connections.

AC Control Power Supply Connection

Separate AC Control Power supply is required to power the electronics of the **VMX Series** starter. 120VAC is standard, order 240 VAC (optional) if necessary for your line power supply configuration. The control voltage must be connected to terminals marked A1 and A2 of TB-2 as shown in figure 5.1 (these are also Terminal No.'s 21 and 22). This control voltage must be customer supplied, unless an optional control power transformer (see table below) has been supplied with the unit.

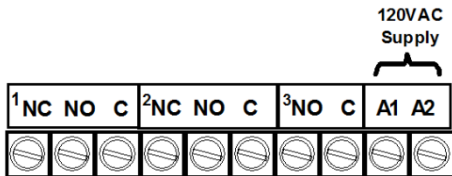

Figure 5.1
Control Power Supply Connection
TB-2

Control Power Requirements

When sizing a control power transformer for the **VMX...-BP Series** starter use the chart below for minimum sizes or supply capacity. Any additional control devices powered by the same CPT must be added to the above values to ensure proper operation of the Bypass Contactor.

VMX ...-BP Model	PC Boards	Fans	-BP: Bypass Contactor Inrush	-BP: Bypass Contactor Sealed	Recommended minimum CPT Rating
VMX-18 to 48	48	(Inc. in PCB)	95	9	100
VMX-62 to 112	48	(Inc. in PCB)	220	17	250
VMX-150 to 160	48	72	298	12.3	500
VMX- 210 to 275	48	100	380	11.6	500
VMX-361 to 450	48	150	571	14	750
VMX-550 to 600	48	200	1000	29	750

Control Fusing

Output relays in TB2 must be protected from currents in excess of 5A, either with a fuse or with other suitable current protection devices.

A dedicated fault output for use in PLC or interposing relay control is available on TB1. This opto-isolated triac switch is rated for 50mA max., 10-250V AC. Any circuit connected to it must be fused accordingly.

Three-Wire Control Connection

For standard 3-wire control, connect dry (voltage free) contacts for the Stop / Start buttons as shown on the diagram directly above the terminal strip. Connect the NO contact of the Start button to Terminal 1 (far left terminal), the common point between the Stop and Start to Terminal 2 (2nd from left) and the NC from the Stop button to Terminal 3 (3rd from left).

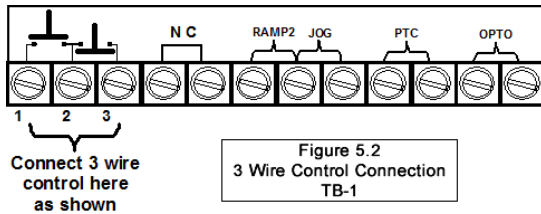

Seal In Contact

The **VMX Series** uses an internally pre-wired “seal-in” contact around the Start button (Terminals 1 and 2). No external relay or auxiliary output connection is necessary.

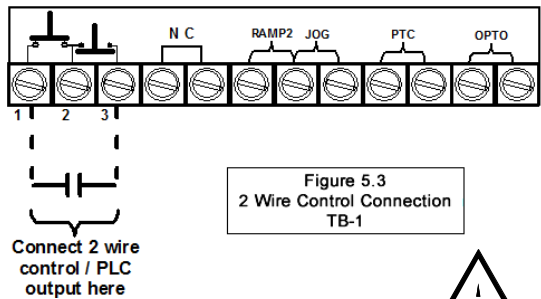

Two Wire Control: Relay / PLC Connection

An alternate connection for automated or unattended operation replaces the start/stop push buttons by connecting a dry (voltage free) maintained contact closure between terminals 1 and 3 as shown in Figure 5.3. When this contact is closed, the **VMX Series** starter will start and run. When it is opened, it is the same as a Stop command.

Note: When a maintained contact is used for start/stop it is advisable to set the overload relay to the manual reset position. This will prevent the motor from restarting if the thermal overload trips and then cools down.



CAUTION!

Control Terminals 1-10 of TB1 are configured using solid state devices powered internally with a 24VDC power supply. To prevent damage to the **VMX Series** control board, use dry (unpowered) contact closures only when connecting to these terminals.

If existing 120VAC or other powered control circuit must be interfaced, use isolating relays and control the **VMX Series** with 2 wire control as shown above.

Interlock Connection

TB1 provides a connection point for an external dry (voltage free) N.C. (Normally Closed) interlock device between terminals 4 and 5. Examples where this interlock connection would be used include low oil, high temperature, or excess vibration dropout from user supplied devices. A factory-installed jumper is provided which allows the **VMX Series** unit to operate if external interlocks are not used. If this jumper is removed and an interlock is not used, the **VMX Series** unit will not function.

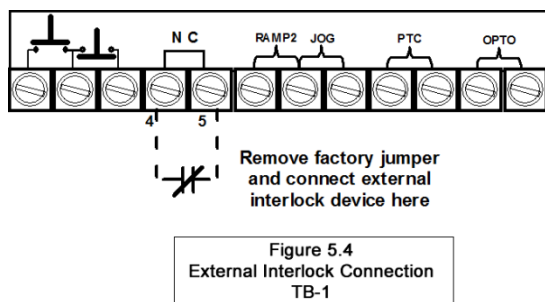

PTC Thermistor Input

The **VMX Series** starter is provided with input terminals for connecting a PTC (Positive Temperature Coefficient)

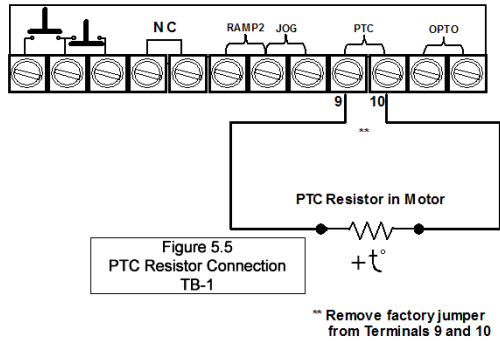

Thermistor that may be imbedded in the motor. These are specialized resistors imbedded in some motor windings that increase in resistance as the temperature increases. When the **VMX Series** detects that the PTC input resistance is too high, it initiates a PTC trip, and displays [**PTc**] on the readout. This is independent of the Thermal Register overload current protection and provides supplemental protection for high motor ambient temperature applications. Terminals for this input are provided with a factory jumper that must be removed if the PTC input is used. These are Terminals 9 and 10 located on TB1.

PTC resistors are also found in other devices such as bearings, air receivers, oil or coolant reservoirs and air discharge systems that may

require shutdown of the motor.

PTC Resistor Values:

The resistance must be less than or equal to 750 Ω at 25°C. If multiple resistors are used in the motor, the sum of all resistors in series must equal or be less than this value.

Fault Signal

An optically isolated Triac output is dedicated as a fault indicator on TB1, terminals 11 and 12, labeled “**Opto**”. The output Triac switch is rated for 10 - 250 VAC, **50 mA (maximum)**. If the three programmable Output Auxiliary

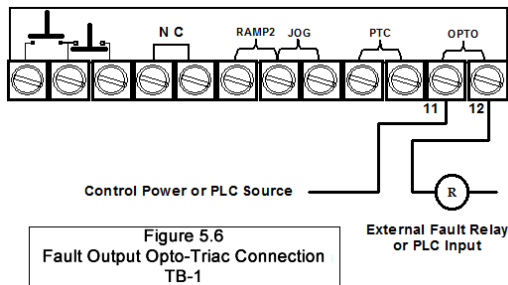

Relays are being used for other functions; this output can easily be hooked up to a PLC or small external relay to provide a Fault signal. This Fault Output operation is permanently fixed at “Any Trip”, duplicating the Relay setting 16 as shown in Table 5.6.10 of the Advanced Installation, Operation and Programming Manual.

This output is permanently set to this function and is not programmable.

Dual Ramp and Jog Features

TB1 includes provisions for enabling the Dual Ramp and Jog functions by using external contact closures. Both features use a common +24VDC from Terminal 7 however, they can be used independently of each other or together. See Section 5.6.2. and 5.6.3 of the Advanced Installation, Operation and Programming Manual for full function description and setup.

Dual Ramp Command

Closing a dry (voltage free) contact between TB1, terminals 6 and 7 will enable Ramp 2, and the **VMX Series** starter will respond to the settings for Ramp 2 in **F015 - F018**. If no contact closure is present, the **VMX Series** starter defaults to the Ramp 1 parameters (**F011 – F014**). See Section 5.6.2. of the Advanced Installation, Operation and Programming Manual for full function description of how to setup the Dual Ramp Feature.

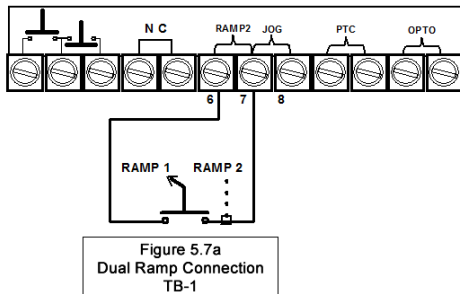

The Dual Ramp feature is useful in instances where the load changes significantly. *Example:* a loaded or unloaded conveyor belt. The characteristics for starting an unloaded conveyor can be programmed for ramp 1. The characteristics for starting a loaded conveyor can be programmed for ramp 2. Ramp 2 can also be programmed for Full Voltage / Across-the-Line starting by setting the ramp time to 0 and Current to 600%.

Dual Ramp is also useful in 2-speed motor applications. Simply use an auxiliary contact from one of the speed contactors to select Ramp 2 so that separate ramp profiles can be used.

Jog / Remote Command

Connecting a dry (voltage free) contact between TB1, Terminals 7 and 8 will enable the Jog feature. A Start command (Run Command or Start button) is required to activate the Jog feature. See Section 5.6.3. of the Advanced Installation, Operation and Programming Manual for full function description of how to setup of the Jog Function.

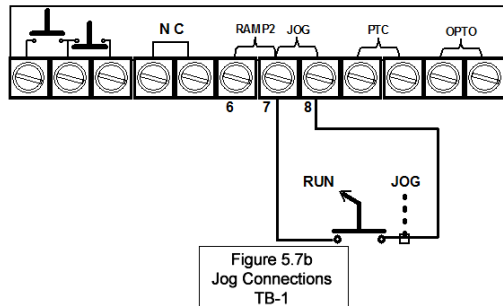

The Jog feature can be used for tasks such as lining up machines for blade or bit changes or inching belts along to check tracking.

This input is also used to change the function of the Serial Communications port control through **F068**. For additional information, see user manual.

Output (Auxiliary) Relay Contacts

Three programmable auxiliary relays are on TB2. The **VMX Series** starter comes with three programmable dry relay output contacts. Outputs 1 and 2 are Form C (SPDT), with a Common, N.O. and N.C. Output 3 is a Form A, (SPST), N.O. contact. It is not necessary to use the programmable output auxiliary relays in the Start / Stop circuit. An internal seal-in relay is provided elsewhere (see 4.2.2.a above). Motortronics recommends fusing all outputs with external fuses. The relays are rated for 240 VAC, 5 A and 1200 VA.

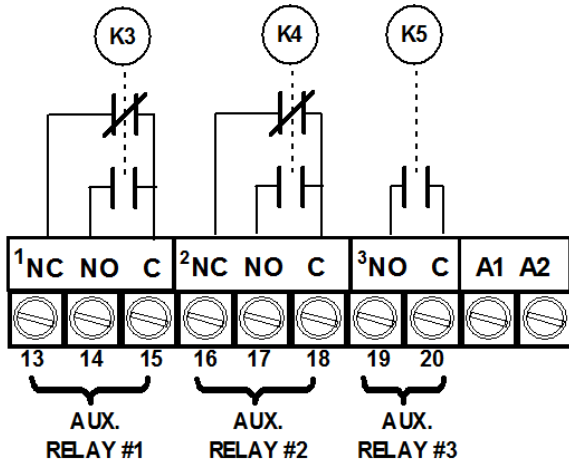

Figure 5.8
Auxiliary Connections
TB-2



Note:

It is not necessary to use the programmable output auxiliary relays in the Start / Stop circuit. An internal seal-in relay is provided elsewhere (see “Three Wire Control Connections”).

Factory default settings for these relays are as follows:

AUX 1 – Run / Stop (see **F060**). This contact changes state upon a Start command, returns to normal on Stop (or Begin Decel if active).

AUX 2 – At-Speed / Stop (see **F061**). This contact changes state upon the **VMX Series** detecting At-Speed, and returns to normal on Stop. At-Speed is determined by the **VMX Series** detecting the current dropping after reaching End-of-Ramp.

AUX 3 – Any Trip (see **F062**) this contact closes when any trip condition 5 – 15 (as defined in Table 5.6.10 of the Advanced Installation, Operation and Programming) occurs.

All relays can be reprogrammed for a wide variety of functions. See Section 8 of the Advanced Installation, Operation and Programming Manual for additional relay programming details.

Bypass Contactor Control

On **VMX...-BP** starters, an internal dedicated connection is used at the factory for automatically controlling the Bypass Contactor. Field wiring for Bypass Contactor operation is not required.

Independent Bypass Contactor Control

The **VMX...-BP Series** starters use standard industrial contactors that can be controlled independent of the starter electronics if necessary. When doing so, it is necessary to size the starter based upon the ATL (Across-the-Line) selection chart so that the contactors are rated for ATL duty instead of normal Shunt Duty. (See Section 1.2.3. of the Advanced Installation, Operation and Programming Manual). Supplemental overload protection will be required (See Section 3.1.3. of the Advanced Installation, Operation and Programming).

Units have external terminal blocks marked for this purpose (see Appendix 5 of the Advanced Installation, Operation and Programming Manual for additional drawings). A dry (voltage free) contact closure between these terminals will close the bypass contactor immediately. The Bypass Contactor coil voltage is the same as the control voltage (120VAC unless the optional 240VAC control is specified), and the voltage on these terminals is the same as the coil voltage.

No field wiring is necessary to these terminals if this feature is not used.

Independent
Bypass Control
Terminals 18 - 160A Units

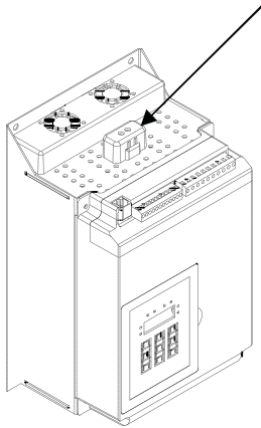

Independent
Bypass Control
Terminals: 210 – 1000A without integral bypass

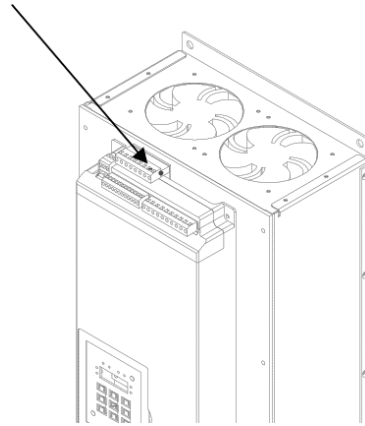

Chapter 3 - Sequence of Operation

Starting:

1. Apply three phase power to the unit. The motor should not run until a Start command is applied.
2. Apply control power and check that the "Power On" LED comes on.
3. Status Display should read **[0000.]** showing no current in Phase A (minor flickering of the first digit is common).
4. Apply the Start (Run) command. The motor should begin to accelerate. Status display will read Phase A Amps at an increasing rate.
5. When the motor reaches full speed, the "At Speed" LED comes on and the Bypass Contactor will close. Status display should show a sharp decrease in Phase A Amps.
6. If the motor does not fully accelerate, decelerates, or stops during the acceleration period, hit the Stop button immediately and open the disconnect line.

Stopping:

If Pump-Flex Decel is Disabled (factory default) in F024:

1. Remove the Run Command (or hit the Stop button).
2. At-Speed LED will go out and Bypass Contactor will open. Status display should read **[0000.]** indicating no current on Phase A.
3. Motor will coast to a stop according to load inertia and friction.

If Pump-Flex Decel is Enabled in F024:

1. Remove the Run Command (or hit the Stop button).
2. At-Speed LED will go out and Bypass Contactor will open. Status display should briefly read Phase A Amps increasing as motor begins to decelerate.
3. Motor should begin to slow down. Status display should begin to show decreasing motor amps.
4. When motor reaches Stop Level, VMX should turn off. Status display will again show **[0000.]**

If the unit does not follow this operational sequence please contact the factory or refer to the VMX Series Troubleshooting Guide.

Chapter 4 – Programming

It is best to operate the motor at its full load starting conditions to achieve the proper time, torque and ramp settings. Initial factory settings are set to accommodate general motor applications and provide basic motor protection. Advanced features must be enabled via programming. The only parameter that **MUST** be set by the user is motor FLA (**F001**).

Digital Interface: The *VMX Series* Soft Starter includes a digital keypad with eight LEDs, seven command keys, and an LED display with four alphanumeric digits.

**MOTOR FLA (F001)
must be programmed
for unit to operate!**



Figure 6.

Table 5.: VMX Series Display Features		
Keys	Reset	Clears the Trip indication and releases the Trip Relay.
	Fn	Enters or exits the Program Mode.
	Up and Down Arrows	Navigates through the Status Display Mode, scrolls up and down through the Function List, increases or decreases the value of the active (flashing) digit and scrolls through the fault history. When entering values, holding the key down for more than 2 seconds will activate Auto-step, which increases its rate the longer the key is held down.
	Right and Left Arrows	Each key press shifts the active (flashing) digit to the right or left by one position, allowing you to change higher values of functions without waiting to Auto-step though large numbers.
Green LEDs	Power On	Control power is available at A1 and A2
	At Speed	The motor is at full power and the Bypass Contactor has been commanded to pull in. The SCRs are at full conduction and current has dropped.
Yellow LEDs	Shunt Trip	Two or more SCRs in opposing phases have shorted, and power is flowing to the motor in the Off mode. See section 7 of the Advanced Installation, Operation and Programming Manual for additional information.
	Shorted SCR	There is no voltage drop across at least one SCR phase assembly, indicating that at least one SCR is shorted. See section 7 of the Advanced Installation, Operation and Programming Manual for additional information.
	Over Current	Overcurrent LED lights for three sets of fault conditions: 1) During start, the unit saw current exceed the normal rate of increase in the first 250ms. 2) During Run, current exceeded either the OC setting in F042 for the delay set in F043 . This LED will be accompanied by oCA , oCC or oCd on the display. 3) The unit has seen a Short Circuit exceeding 10x FLA for 12.5ms. This LED will be accompanied by SCA , SCC or SCD display.
	Phase Loss	One or more of the phase currents dropped below the threshold during starting or running.
	Over Temp	Starter has tripped due to excess heat sink temperature. This will automatically reset.
	Over Load	Starter has tripped due to the Thermal Register reaching 0000. The Overload must reset before this fault can be cleared.
	Display	8888.

Display Modes

There are three modes of display: The Status Display Mode, the Program Mode, and the Fault Mode.

Status Display Mode (Default Display)

The Status Display Mode displays seven “screens” of information. Motor Currents (3 phases), Remaining Thermal Capacity, Ground Current, Remaining Time on the Process Timer, and Time Base of the Time Clock Controller. This is also the entry screen for going into the Program Mode.

Status mode:

[0000.] The initial display on power up is four digits and the decimal. This indicates the motor current for Phase A of the motor.

[0000] Scroll UP to display four digits only (no decimal). This indicates the motor current for Phase B. While viewing Phase B, press the UP arrow again to view Phase C current.

[G000] Scroll UP to display the “G”. This shows the value of the current flowing to ground on the motor leads.

[H000] Scroll UP to display the “H”. This indicates the value of the remaining thermal capacity percentage of the motor (i.e. H070 = 70% remaining thermal capacity)

[0000] Scroll UP again to display the Process Batch Timer (described in Section 5.6.7 of the Advanced Installation, Operation and Programming Manual).

[00.00] Scroll UP to display two pairs of digits separated by a point: This indicates the time base of the Time Clock Controller (described in Section 5.6.7 of the Advanced Installation, Operation and Programming Manual). If the display shows [00.00], the TCC is not enabled. This follows the time settings in **F075 – F080**.

Program Mode

The starter must be STOPPED in order to enter the Program Mode. Use the Program Mode to view or change Function (Fn) settings. To enter the Program Mode, press the **[Fn]** key once from the Status Screen described in section 5.3.1 of the **Advanced Installation, Operation and Programming Manual**. The first time you enter the Program Mode after power has been cycled to the starter, the initial function **[F001]** should be displayed with the selected digit flashing. If the **VMX Series** starter has been programmed and power to the unit has not been cycled, the readout will display the last function viewed or changed. To change to a different function, use the arrow keys.

Viewing Function Programming and Values

The programming of each individual Function can be viewed without making changes (values can also be viewed in the Run Mode however, no changes can be made). Each Function is signified by the letter “F” in the beginning of the data, the 4 digit value of the function follows after pushing the **[READ/ENTER]** key

- **[F001]** The “F” indicates the programmable Function.
- **[0000]** This is the present setting of the applicable function.

This display may include decimals between digits depending on the function setting’s range and incremental steps **[F001]** The “F” indicates the programmable Function.

[0000] This is the present setting of the applicable function. This display may include decimals between digits depending on the function setting’s range and incremental steps.

Pressing the [Fn] key again will return to the Function display without making changes.

Press Key...	Display Shows...	Means...
	0120.	Phase A Current
↑	0121	Phase B Current
↑	0120	Phase C Current
↑	G002	Ground Fault Current
↑	H183	Remaining Thermal Capacity
↑	0060	Process Timer Remaining Time
↑	13.30	Time Clock Time Base
↑	0120.	Loop Back to Phase A Current

Figure 7: Reading the Status Display

Changing a Function's Set Value

From the instructions above, after pressing the **[READ/ENTER]** key the display will show the value of that function with one digit flashing (usually the rightmost digit). Flashing indicates this is the digit to be altered (similar to cursor position). Use the UP arrow key to increment the value of the flashing digit. Use the DOWN arrow key to decrement the value of the flashing digit. Use the LEFT or RIGHT arrow to select the next digit to be altered. Values can only be changed within the Adjustment Range of the function parameter.

Pressing the **[READ/ENTER]** key again will store the new programming for that Function and return to the Function display.

If the display shows **[Inh]** when trying to store the changes, the unit is running and must be Stopped, or a Password has been set up to prevent access and must be entered first. See section 5.6.12 of the Advanced Installation, Operation and Programming Manual for details about this feature.



Caution!

If the Fn key is pressed or power is lost before the [READ/ENTER] key is pressed, the VMX Series Starter will not store the selected value in memory.

Fault Mode

The Fault Mode Display provides information to the operator when a fault occurs and allows the operator to review fault history. Refer to described in Section 7 of the Advanced Installation, Operation and Programming Manual for details. Fault codes are displayed by 3 alpha characters. The first and second characters (reading left to right) are the initials for the applicable English-language fault name. The third or right-most character can be either A, c, or d to denote when the fault occurred. "A" denotes Acceleration. "c" denotes Constant speed. "d" denotes Decel or Stopped.

Example 1: Figure 8
Entering a new FLA setting into Function 001

Viewing a Function’s Set Value

[0000.] Indicates Phase A is drawing no current (unit is in Off mode).

Press the [Fn] key

[F001] Indicates this is Function 001 (Motor FLA).

Press [READ/ENTER] key to view the F001 value

[0048] Indicates the programmed motor FLA is 48 Amps. The right most digit (8) is flashing, indicating that this is the digit that you will alter (cursor position).

Press the UP Arrow key to increase this digit value

[0049] Indicates you have increased the right most digit to a value of 9.

Press the LEFT Arrow key to shift left to the next digit

[0049] The second digit from the right is now flashing, indicating a new cursor position.

Press the UP Arrow key to increase this digit value

[0059] Indicates you have increased the 2nd to right digit to a value of 5 (10’s place).

Press [READ/ENTER] key to store the new value

[End] The word “End” will flash briefly to indicate that the new value has been entered and accepted. After flashing once, the display will revert to showing the Function number.

Press the [Fn] key

[0000.] Returns to the Default Display, indicating Phase A is drawing no current

Example 1: Setting the Motor FLA

Change FLA from 48 to 59A

Press Key...	Display Shows...	Means...
	0000.	Phase A Current
Fn	F001	Function #1 Selected
READ ENTER	0048	Previous Setting of Function #1
↑	0049	New Value of First Digit
←	0049	Cursor (flashing) Position Shift
↑	0059	New Value of Second Digit
READ ENTER	End	Value Accepted (flashes once)
	F001	Return to Function # Display

Figure 8: Changing a Function Value

Note: When first entering FLA into a new unit, pressing the Up arrow key will jump the readout value immediately to ½ of the unit Max. Amp rating and it will never go below that again. Any unit thought to be new which has a value other than 0000 in F001 upon setup, has been programmed previously and should be reset to factory defaults before proceeding.

Program Function List

Fn #	Group	Function Description	Adjustment / Display Range	Setting Increments	Factory Setting	Setting	Setting
F001	Motor and Overload Info.	Motor Nameplate FLA FLA must be programmed for starter to function.	50-100% of Max Amp Rating. Upper limit of range automatically adjusts downward as Service factor is increased.	1 amp	0		
F002		Motor Nameplate Service Factor	1.00 - 1.30 SF	0.05	1.0 SF		
F003		Overload Class During Start	NEMA / UL Class 5 - 30	5	Class 10		
F004		Overload Class During Run	NEMA / UL Class 5 - 30	5	Class 10		
F005		Overload Reset	0 = Manual 1 = Auto 2 = Disabled Overload	1	0 (Manual)		
F006-9		Reserved for factory use					
F010	Starting and Stopping Modes	Ramp Type Selection VR = Voltage Ramp CR = Current PID Ramp 1 = Ramp 1, 2 = Ramp 2	Setting 1 = VR1 + VR2 Setting 2 = CR1 + CR2 Setting 3 = VR1 + CR2 Setting 4 = CR1 + VR2	1	1 VR1+VR2		
F011		Initial Torque (VR) of Ramp 1	0-100% Line Voltage	1%	60%		
F012		Initial Torque (CR) of Ramp 1	0-600% Motor Current	1%	200%		
F013		Accel Ramp Time of Ramp 1	1-120 seconds	1 second	10 seconds		
F014		Max Current Limit of Ramp 1	200 - 600% Motor Current	1%	350%		
F015		Initial Torque (VR) of Ramp 2	0-100% Line Voltage	1%	60%		
F016		Initial Torque (CR) of Ramp 2	0-600% Motor Current	1%	200%		
F017		Accel Ramp Time of Ramp 2	1-120 seconds	1 second	10 seconds		
F018		Max Current Limit of Ramp 2	200 - 600% Motor Current	1%	350%		
F019	Jog Modes	Voltage Jog	5 – 100% Line Voltage	1%	50%		
F020		Time of Voltage Jog	1 – 20 Seconds	1 second	10 seconds		
F021		Current Jog	100 – 500% Motor Current	1%	150%		
F022	Kick Mode	Kick Start Voltage	0 = Disabled, or 10 - 100% Line Voltage	1%	0 Disabled		
F023		Kick Start Time	0.1 - 2 Seconds	0.1second	0.8 sec		

Fn #	Group	Function Description	Adjustment / Display Range	Setting Increments	Factory Setting	Setting	Setting
F024	Pump Flex Decel Mode	Pump Flex Control / Deceleration Ramp	0 = Disabled (coast to stop) 1 = Enabled, except after OL trip 2 = Enabled, continued Decel even if there is an OL trip	1	0 Disabled		
F025		Begin Decel Level (BDL), Immediate Drop Down Torque	0 - 100 % of Output Voltage	1%	60%		
F026		Decel Shut Off Voltage	0 to (BDL minus 1)% Voltage	1%	30%		
F027		Decel Ramp Time	1 – 60 Seconds	1 second	10 seconds		
F028	Restart	Restart Delay Time (Sequential Start Delay)	0 = Disabled, or 1-999 seconds after a Power Loss (Status can be read in F054)	1 second	0 Disabled		
F029		Reserved for Factory Use					
F030	Run Timer and Time Clock Controller Modes	Process Control Timer Selection	0 = Disabled (No timer operation) 1 = Minimum Batch Run Timer 2 = Permissive Run Timer	1	0 Disabled		
F031		Run Timer Time for use in F030 above	1-9999 minutes after a Start Command or Start Event from TCC	1	1		
F032		24hr Time Clock Controller (TCC) Start Event Mode. Choose from "One Shot" or 1 to 7 "Start Events" in F033 – F039 Run time for this mode comes from F030 above.	Start Event Cycle (SEC) Settings 0 = One Shot: Start Event comes from Start command only 1 = Loop SEC every day 2 = Loop SEC every 2nd day 3 = Loop SEC every 3rd day 4 = Loop SEC. every 4th day 5 = Loop SEC. every 5th day 6 = Loop SEC. every 6th day 7 = Loop SEC one day per week 8 = Single 24hr SEC (until programmed again)	1	0 One Shot		
F033		Start Event #1 Start Time	00:00-23:59 (hh:mm) or OFF	1	OFF		
F034		Start Event #2 Start Time	00:00-23:59 (hh:mm) or OFF	1	OFF		
F035		Start Event #3 Start Time	00:00-23:59 (hh:mm) or OFF	1	OFF		
F036		Start Event #4 Start Time	00:00-23:59 (hh:mm) or OFF	1	OFF		
F037		Start Event #5 Start Time	00:00-23:59 (hh:mm) or OFF	1	OFF		
F038		Start Event #6 Start Time	00:00-23:59 (hh:mm) or OFF	1	OFF		
F039		Start Event #7 Start Time	00:00-23:59 (hh:mm) or OFF	1	OFF		

Fn #	Group	Function Description	Adjustment / Display Range	Setting Increments	Factory Setting	Setting	Setting
F040	Current and Ground Fault Protection	Current Imbalance Trip	0 = Disabled, or 5 - 30% imbalance	1%	0 Disabled		
F041		Current Imbalance Trip Delay	1 - 20 seconds	1 second	2 seconds		
F042		Over Current Trip	0 = Disabled, or 100 - 300% of motor FLA	1%	0 Disabled		
F043		Over Current Trip Delay	1 - 20 seconds	1 second	1 second		
F044		Under Current Trip	0 = Disabled, or 10 - 90% of motor FLA	1%	0 Disabled		
F045		Under Current Trip Delay	1 - 60 seconds	1 second	2 seconds		
F046		Ground Fault Trip	0 = Disabled, or 5 - 90% of CT ratio from Fn 74	1%	0 Disabled		
F047		Ground Fault Trip Delay	1 - 60 seconds	1 second	2 seconds		
F048	Lockouts, Reset and Internal Protection	Coast Down (Back Spin) Lockout Timer	0 = Disabled, or 1 - 60 minutes	1 minute	0 Disabled		
F049		Maximum Starts per Hour	0 = Disabled, or 1 – 10 starts	1	0 Disabled		
F050		Minimum Time Between Starts	0 = Disabled, or 1 - 60 minutes	1 minute	0 Disabled		
F051		Internal Protection Settings	1 – 255 See 5.6.9.a	1	127 Enable all		
F052		Auto Reset on Selected Faults	Fault Preferences 1 – 12 See 5.6.9.b Fault Reset Selection Table	1	4: Phase Loss only		
F053		Auto Reset Attempts	0 = Disabled, or 1-10 attempts	1	1		
F054		Restart Delay Time Value Readout (for F028)	0-999 Seconds	1	0		
F055		Coast Down Timer Value for F048	1-3600 Seconds	1	0		
F056		Starts Per Hour Timer Value for F049	1-3600 Seconds	1	0		
F057		Starts Per Hour For F049	1-10 Starts	1	0		
F058		Time Value Between Starts for F050	1-3600 Seconds	1	0		
F059		Thermal Capacity to Start for F005	0-100 % Thermal Capacity	1	0		
F060	Output Relays	Aux Relay 1 setting	Operation # 1 – 26: see "Aux. Relay Settings Chart"	1	1		
F061		Aux Relay 2 setting	Operation # 1 – 26: see "Aux. Relay Settings Chart"	1	2		
F062		Aux Relay 3 setting	Operation # 1 – 26: see "Aux. Relay Settings Chart"	1	16		
F063		Aux. Relay Delay Timer (for Operations 22-26)	0 (Disabled), or 1-999 seconds	1 second	0 No Delay		
F064		Reserved for factory use					

Fn #	Group	Function Description	Adjustment / Display Range	Setting Increments	Factory Setting	Setting	Setting
F065	Communications	Communications	0 = Disabled 1 = Enabled (11Bit) 2 = Enabled (10Bit)	1	0		
F066		Baud Rate	4.8, 9.6 and 19.2 KB	3 rates	9.6 KB		
F067		Modbus Address	1 - 247	1	1		
F068		Remote Starter Control	0 = Disabled 1 = Enabled w/ Start button 2 = Enabled w/o Start button 3 = Enabled by Jog / Remote Input	1	0		
F069		Reserved for factory use					
F070	System Settings	Parameter Lock Customer Password	0 – 999 0 = Disabled Any Other Numbers = Password	1	0 (displays encrypted code)		
F071		System Clear / Reset	0 = Disabled 1 = Clear THR and Lockout Timers 2 = Reset to Factory Default Settings	1	0		
F072		Reserved for Factory Use					
F073		Frame Rating	18 - 1250	1	By Model (defaults to 48)		
F074		CT Value	40-1200	5	By Model (defaults to 40)		
F075		Year	2000 - 2047	1 year	2000		
F076		Month	1 - 12	1 Month	1		
F077		Day	1 - 31	1 Day	1		
F078		Hour	0 - 23	1 Hour	0		
F079		Minute	0 - 59	1 Minute	0		
F080		Second	0 - 59	1 Second	0		
F081		Revision #	-	-	Factory Setting		
F082 – F084		Reserved for factory use					

Fn #	Group	Function Description	Adjustment / Display Range	Setting Increments	Factory Setting	Setting	Setting
F085	Fault History and Run Data	Fault History #1, Latest Fault	0 = No fault history, or Fault # 1 - 27: see Fault code list	1	0		
F086		Time Stamp, Fault #1 Based on F078-80	00.00-23.59 (hh.mm) [hh = 00-23; mm = 00-59]	00.01	00.00		
F087		Date Stamp, Fault #1 Based on F076-77	01.01 – 12.31 (MM.DD) [MM = 01-12; DD = 01-31]	00.01	01.01		
F088		Fault History #2, Previous Fault	0 = No fault history, or Fault # 1 - 27: see Fault code list	1	0		
F089		Time Stamp, Fault #2	00.00-23.59 (hh.mm) [hh = 00-23; mm = 00-59]	00.01	00.00		
F090		Date Stamp, Fault #2	01.01 – 12.31 (MM.DD) [MM = 01-12; DD = 01-31]	00.01	01.01		
F091		Fault History #3, Oldest Fault	0 = No fault history, or Fault # 1 - 27: see Fault code list	1	0		
F092		Time Stamp, Fault #3	00.00-23.59 (hh.mm) [hh = 00-23; mm = 00-59]	00.01	00.00		
F093		Date Stamp, Fault #3	01.01 – 12.31 (MM.DD) [MM = 01-12; DD = 01-31]	00.01	01.01		
F094		Run Time, Hours	000.0 – 999.9 hours	0.1 hours	0		
F095		Run Time, 1000 Hour Overflow	0000 – 9999 thousand hours	1 k-hour	0		
F096		Run Cycle Counter	0000 – 9999 times	1 times	0		
F097		Run Cycle Counter 10K overflow	0000 – 9999 10 thousand times	1 10k times	0		

Function 51 Internal protection features

Several protection features in the **VMX Series** are accomplished with internal hardware and use software switches in Function 51 to enable or disable them. The following chart shows these functions and the factory default settings. Refer to the Advanced Installation, Operation and Programming Manual, **Section 5.6.9.a** for details on how to change these settings.

Protection Function	Description	Default Setting
Phase Rotation Trip	Phase Rotation protection. Phase rotation must match selection in Bit #2 below. Setting to Off (0) will make the VMX insensitive for use behind a reversing contactor	Off
Expected Phase Sequence	2 = A-B-C Phase Rotation Sequence Only 0 = A-C-B Phase Rotation Sequence Only	A-B-C Rotation
Phase Current Loss	Phase Current Loss, any phase current reading is less than 8 - 20% (Depending on frame size) of unit max amp rating after 3 seconds from Start command.	On
Shorted SCR Lockout	At least one SCR has shorted; there is no voltage drop across the SCR phase assembly.	On
Shunt Trip	Shunt Trip of the main Circuit Breaker or Isolation Contactor (if provided and wired to an Aux. relay in F060-F061)). 2 or more SCRs have shorted in opposing phases so current was flowing to the motor while the VMX was in the Off state.	On
PTC Input Trip	PTC Trip function. This can be disabled so that a jumper is not required across the PTC inputs.	On
Line Loss Trip	Protection against loss of input line voltage. Disable when using an In-Line Isolation Contactor or any other system that normally removes line power from the starter. Resets automatically when line voltage returns.	On

Table 6: Function 51 table of Hardware Protection Features

Auxiliary Output Relay Settings

Functions F060 through F062 provide the ability to program the functions of each of the 3 Output Auxiliary Relays. Factory default programming is provided which covers a wide variety of applications, but any of these relays can be changed as per the following chart.



Notes:

Check relay wiring before changing programming to avoid unintended consequences.
Relays programmed to some protection features will not operate if function is disabled elsewhere.

Setting	Relay Operation Description	Setting	Relay Operation Description
1	Run / Stop (Changes on Start, resets on Stop)	14	Ground Fault Trip
2	At Speed / Stop	15	Phase Rotation Trip
3	At Speed / End of Decel	16	Any Trip (#5 - #15)
4	Start / End of Decel	17	Any Trip, (#5-#15) flashing output*
5	Short SCR Trip	18	Coast Down Time Lockout
6	Phase Loss Trip	19	Starts Per Hour Lockout
7	Shunt Trip	20	Time Between Starts Lockout
8	OL (Motor Thermal Overload) Trip	21	Any Lockout (#18-#20)
9	OT (Starter Thermal Over Temperature) Trip	22	Run Timer (F030) Engaged
10	Short Circuit Trip	23	Run / Stop with On-delay from F063
11	Current Unbalance Trip	24	At Speed / Stop with On-delay from F063
12	Over Current (Shear-Pin) Trip	25	At Speed / End of Decel w/ On-delay from F063
13	Under Current Trip	26	Start / End of Decel with On-delay from F063

Table 7: Aux. Relay Settings

*Note: Flash rate for Setting #17 is ½ second On and Off

Fault Mode

The **VMX Series** will automatically enter the Fault Mode when a fault occurs in the motor or starter and display a code indicating the condition that caused a shutdown. Fault codes are three-digits in length and are displayed in alpha characters. The first and second characters (reading left to right) are the initials for the applicable English-language fault name. The third or right-most character can be either A, c, or d to denote when the fault occurred. “A” denotes Acceleration. “c” denotes Constant speed. “d” denotes Decel or Stopped.

A **Fault History** of the past 3 events is stored and can be accessed by using the Up or Down Arrow keys before pressing the Reset button. The first (newest) event is indicated by the decimal point in the lower right corner. A more detailed history with time and date stamps is also kept in Functions 85 through 93.

Fault Codes:

Basic common fault codes are shown in the chart below. For additional details refer to Chapter 7 of the Advanced Installation, Operation and Programming Manual, or contact the factory for assistance.

Fault Condition Description	Fault Display Code Readout	Fault Number Code used in History, F085, F088 and F091	LED Indicator
Over Current during Accel; Const spd; Decel	ocA; occ; ocd	1; 2; 3	Over Current
Phase Loss during Accel; Const spd; Decel	PLA; PLc; PLd	4; 5; 6	Phase Loss
Over Temperature during Accel; Const spd; Decel	otA; otc; otd	7; 8; 9	Over Temp
Over Load during Accel; Const spd; Decel	oLA; oLc; oLd	10; 11; 12	Over Load
Shorted SCR during Accel; Const spd; Decel	SSA; SSc; SSd	13; 14; 15	Shorted SCR
Shunt Trip during Accel; Const spd; Decel	st	16; 17; 18	Shunt Trip
Current Imbalance during Accel; Const spd; Decel	IbA; Ibc; Ibd	19; 20; 21	---
Under Current during Accel; Const spd; Decel	UcA; Ucc; Ucd	22; 23; 24	---
Short Circuit during Accel; Const spd; Decel	ScA; Scc; Scd	25; 26; 27	Over Current
Ground Fault during Accel; Const spd; Decel	GfA; Gfc; Gfd	28; 29; 30	---
Bypass Discrepancy during Accel; Const spd; Decel	bPA; bPc; bPd	31; 32; 33	---
PTC Trip during Accel; Const spd; Decel	PtA; Ptc; Ptd	34; 35; 36	Over Load
Rotation Trip during Accel; Const spd; Decel	rtA; rtc; rtd	37; 38; 39	---

Additional codes that may be displayed

Display Code Readout	Condition Description
nFLA	No Full Load Amps set in F001
Inh	Inhibit: Starter is still Run mode when you are attempting a change in programming, or the starter has Password Protection enabled and you have not entered the password code.
n3Ph	No 3 Phase: No input line voltages on one or more phases
Loc	Lockout: The unit has tripped on Overload and you are attempting to Reset before it is ready, or one of the Duty Cycle Lockout protection features has been enabled.
Err	Error: You are attempting to enter an invalid password

Table 8: Fault and Display code list

Chapter 5 - Motor Overload Protection

Solid State Overload Protection

The **VMX Series** Starter provides true U.L. listed I²t Thermal Overload Protection as a built-in function of the main digital processor for maximum motor protection. It simulates the tripping action of a bi-metallic overload relay, with the accuracy and repeatability of a digital control system. It is adjustable over a wide range and can be easily programmed for different trip curves.

Thermal Memory

The **VMX Series** microprocessor uses a sophisticated “Thermal Register” in the digital memory to keep track of motor heating and cooling over time regardless of the starter’s power status. By using non-volatile memory, the **VMX Series** does not “forget” that the motor has been running even if power to the starter is turned off and back on. Continuous overload protection is provided based on the true thermal condition of the motor.

Thermal Capacity

The Thermal Register is displayed as a percentage. This percentage is the motor’s remaining thermal capacity. The percentage value begins at 100, showing that the motor is cool (has 100% of its capacity available). As the motor heats up or moves toward an overload condition, the percentage begins to drop. The Thermal Capacity is derived from the programmed motor nameplate Full Load Amps (FLA) in Function F001, the Service Factor rating in Function F002, and the Overload Trip Class in Functions F003 and F004. Setting these functions to the proper values provides maximum protection and eliminates nuisance tripping.

Examples:



100% Thermal Capacity remaining at rest



57% Thermal Capacity remaining after starter (43% used)

The Remaining Thermal Capacity can be viewed by using the UP or DOWN arrow keys when in the Status Display mode. From the default Phase A Current screen (dot on right side), press the UP arrow key 4 times to display **[H100]** meaning there is 100% of the Thermal Capacity (H = Heat capacity) remaining in the motor. After starting or running, the motor will use this capacity and the display will show a lower number. For example, after a cold start, the display may read **[H065]** which indicates that the motor has 65% of its thermal capacity remaining (35% used). The Status Display screens cycle back to the beginning, so the Down arrow keys can get to this display as well.

Motor Full Load (FLA) Setting

Use Function F001 to enter motor FLA as indicated on the motor nameplate. (Do not calculate for service factor, this is programmed separately in F002).

Note:

All **VMX Series** starters are shipped from the factory with F001 set to a default value of 0000. If F001 is left at the factory default, the unit will not operate. If the user attempts to start the **VMX Series** without entering the motor nameplate FLA, the starter will Fault and the display will read “nFLA” (no Full Load Amps).



Disabling the Overload Protection

The Overload Protection feature can be disabled if necessary. Please refer to the Advanced Installation, Operation and Programming Manual for instructions and considerations before disabling the Overload Protection



WARNING!

Do NOT disable Overload Protection unless another Thermal Overload Protection device exists in the circuit for all three phases. Running a motor without Overload Protection presents serious risk of motor damage or fire.

Manual Reset

The factory default setting is Manual Reset. This means that when the Overload Trip is activated, the starter cannot be restarted without pressing the Reset key. The Overload Trip will not reset until the motor cools down (see 3.1.3.d). The Manual Reset function is also “trip free”. Holding in the Reset key will not prevent the Overload Trip from activating and protecting the motor.



Note:

When the Overload Trip activates, the Overload LED will glow solid. When the motor cools down, the LED will begin to flash, indicating that the Overload Trip can be reset.

Automatic Reset

If Automatic Reset is necessary, change from Manual Reset to Automatic Reset by using Function F005. (See Section 5. of the Advanced Installation, Operation and Programming Manual for details). In this mode, a 3-wire control circuit will be capable of restart when the **VMX Series** has reset itself after the cool down period.

WARNING!



Two-wire control systems may restart without warning when Auto Reset is selected. Extreme caution should be exercised. To prevent automatic restarting with 2-wire control systems, use external interlocking to provide sufficient warning and safety to operators. A Warning Label similar to that shown below (and the one provided in the packet with this manual) must be located where visible (on the starter enclosure and/or the driven equipment) as required by local code.

**WARNING: MOTOR CONNECTED TO THIS EQUIPMENT
MAY START AUTOMATICALLY WITHOUT WARNING**

NEMA Class Trip Curves

NEMA Class trip curves are based on a common tripping point of 600% of motor Full Load Amps (FLA). Curves vary by the amount of time before the unit trips. As an example, a Class 20 curve will trip in 20 seconds at 600% of FLA. The factory default setting of Class 10 will trip in 10 seconds at 600% of FLA.

Dual Overload Trip Curves

The **VMX Series** Soft Starter provides two separate Overload Trip Protection Curves, one for starting and one for running conditions. The starter's At-Speed detection circuit determines when the motor has reached full speed. When the At-Speed condition is reached, the overload trip curve will shift from the Start to the Run level, as programmed in Functions F003 and F004. See Section 5.6.1 of the Advanced Installation, Operation and Programming Manual for programming details.

Starting Overload Trip Curve

During the start mode, Overload Trip Curves are selectable from NEMA Class 5 through Class 30 only. The default setting of Class 10 allows protection for the overload capacity of the soft starter as well as the motor. Use a higher Trip Class only if nuisance tripping occurs with the default setting.

Running Overload Curve

During the Run mode, Overload trip curves are selectable from NEMA Class 5, 10, 15, 20, 25, and 30. Program the appropriate curve according to the characteristics of your motor and load.

Overload Trip Curve Chart

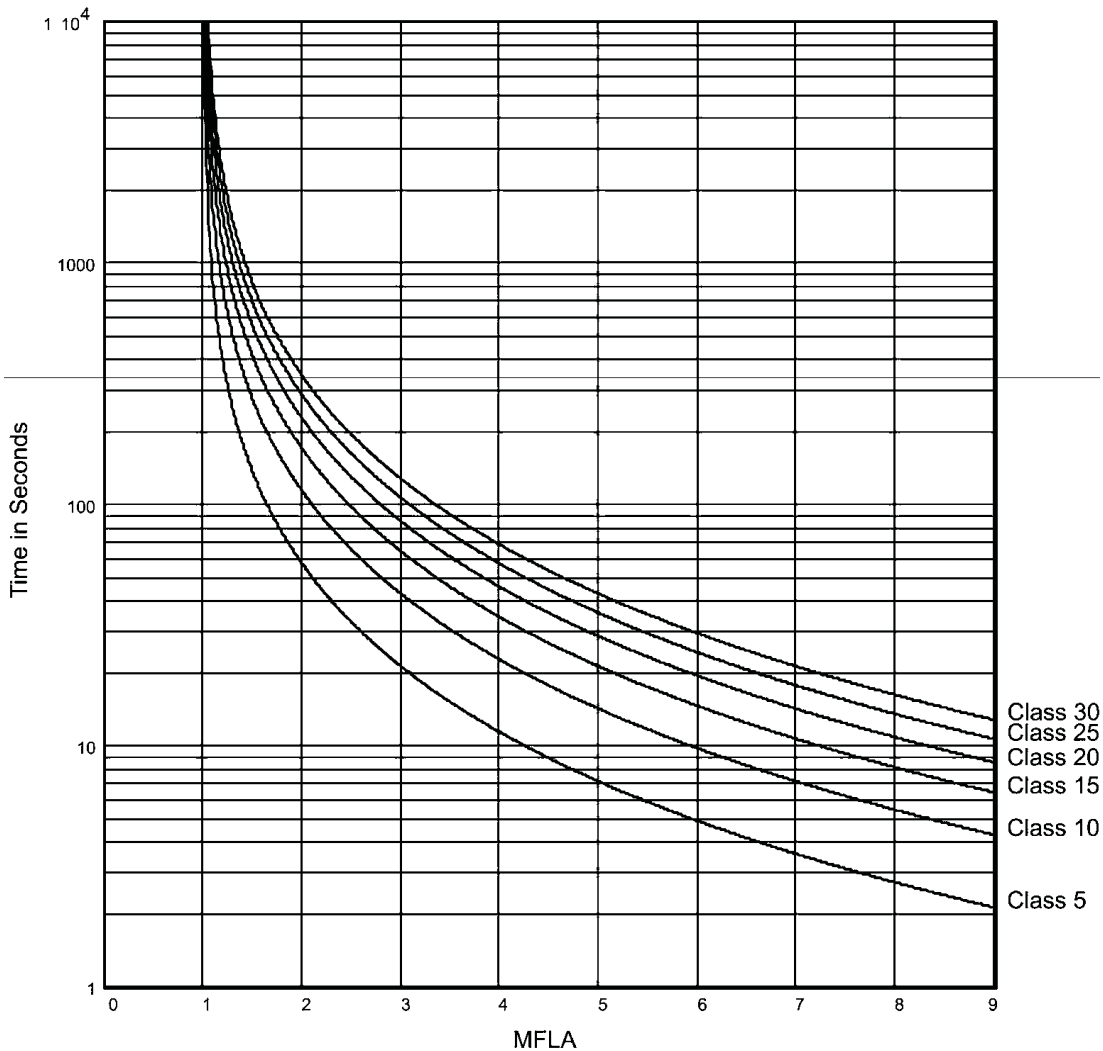

Note: Factory default setting is Class 10 for both Start and Run Overload Protection

Figure 9: VMX Series Overload Trip Curves

Overload Protection During Bypass

When a Bypass Contactor is used to shunt power around the SCRs in the **VMX Series** (as in the VMX...-BP version), overload protection is maintained as long as the **VMX Series** is directly controlling the contactor. No additional Overload Relay is necessary for normal operation.

Special Consideration for Across-the-Line (Direct-on-Line) Contactors

When the Bypass Contactor on a **VMX...-BP Series** has been selected to be used for Across-the-Line restart, supplemental overload protection must be added. For this application, refer to the External Overload Relay Applications supplement and wiring diagram in Appendix 5 and section 4.2.6.a of the Advanced Installation, Operation and Programming Manual for detailed instructions.



For the latest product information
visit us at www.motortronics.com