



Current Transformer

Model 141MR
rev 011218

CERTIFICATIONS:



APPLICATION:

Relaying and metering.

FREQUENCY:

50-400 Hz.

INSULATION LEVEL:

600 Volts. 10 kV BIL. full wave

WINDOW DIAMETER:

8.13"

APPROXIMATE WEIGHT:

44 lbs.

CONNECTIONS:

-Terminals are brass screws No. 10-32 UNF with one flat washer and a split lock washer

Model	141MR
Window Size	8.13
Width	11.10
Height	11.47
Depth	6.00

MODEL 141MR
Window Diameter 8.13"
Approximate weight: 44 lbs.

Catalog Number	Relay Class	Continuous Thermal	
		@ 30°C	@ 50°C
141-601MR	C100	2.0	1.5
141-122MR	C200	2.0	1.5
141-202MR	C400	1.33	1.0
141-302MR	C400	1.5	1.33
141-402MR	C400	1.0	0.8
141-502MR	C200	1.0	0.8

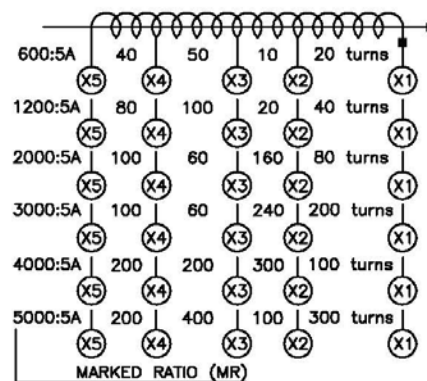
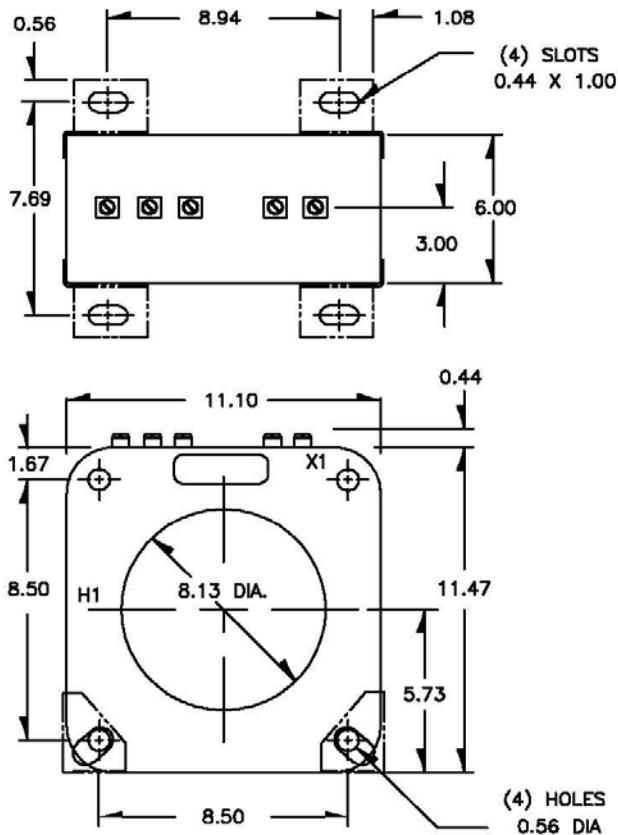

Products are manufactured in a plant whose quality management system has been certified to be in compliance with ISO 9001:2015 by NQA

EXCITATION CURVE

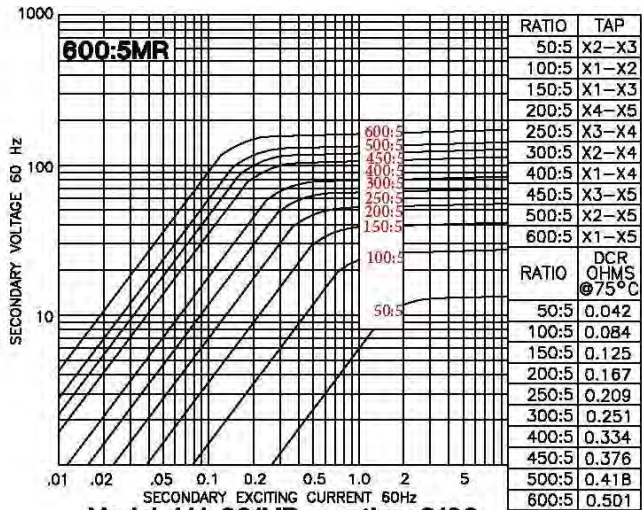

Model 141-60MR - rating C100
TRF= 2.0 @ 30°C, 1.5 @ 55°C amb.

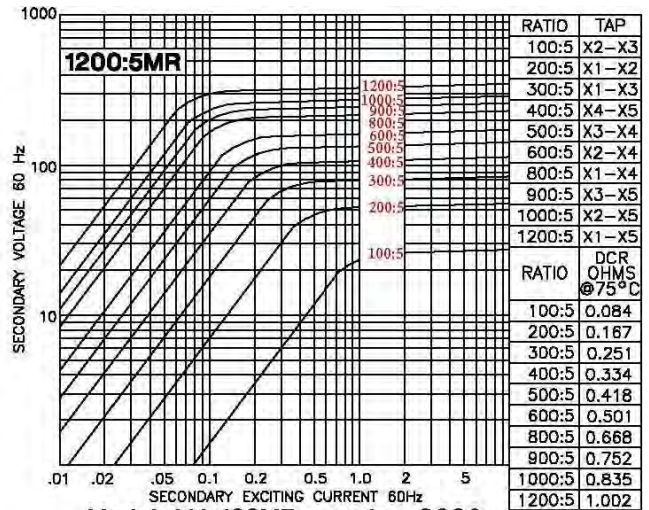

Model 141-122MR - rating C200
TRF= 2.0 @ 30°C, 1.5 @ 55°C amb.

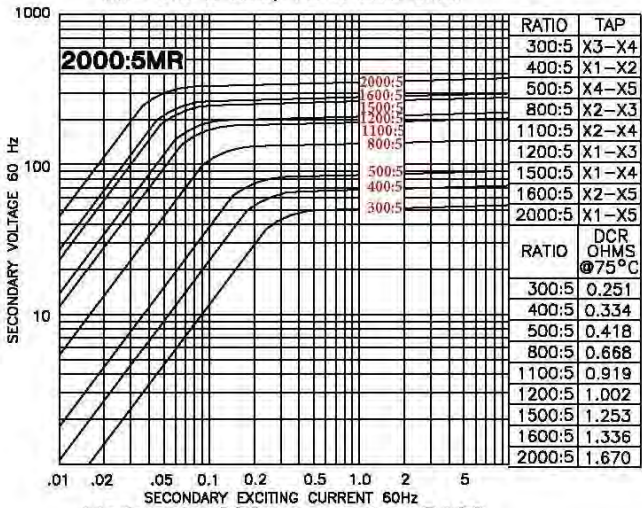

Model 141-202MR - rating C400
TRF= 1.33 @ 30°C, 1.0 @ 55°C amb.

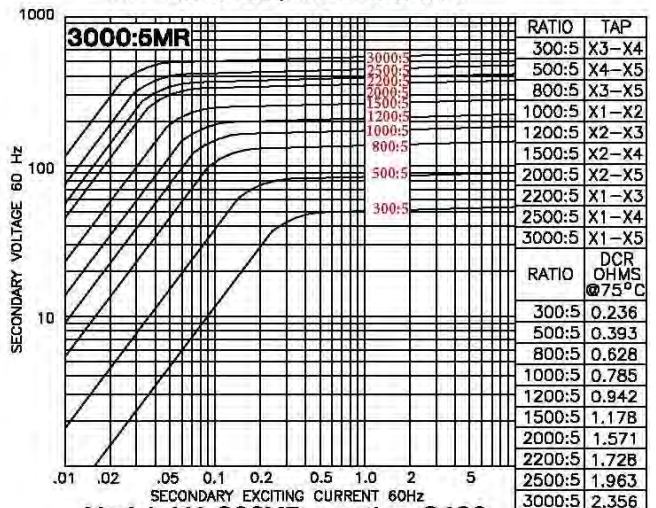

Model 141-302MR - rating C400
TRF= 1.5 @ 30°C, 1.33 @ 55°C amb.

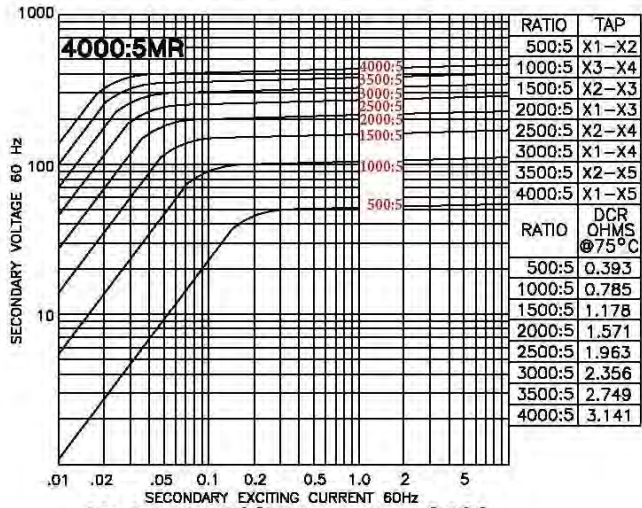

Model 141-402MR - rating C400
TRF= 1.0 @ 30°C, 0.8 @ 55°C amb.

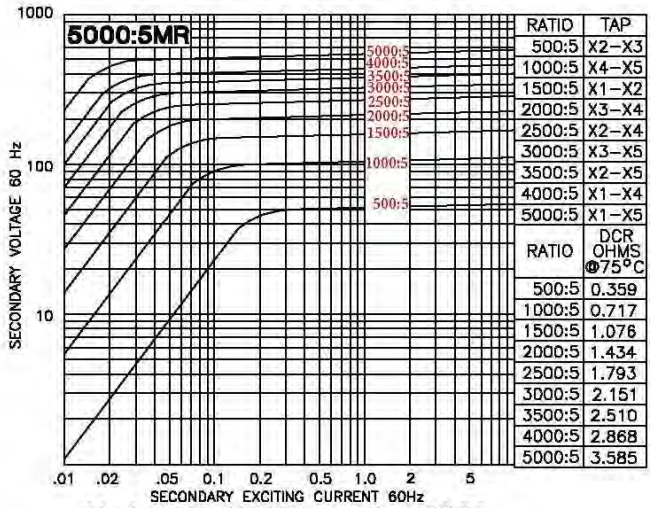

Model 141-502MR - rating C200
TRF= 1.0 @ 30°C, 0.8 @ 55°C amb.