



Current Transformer

Model 19
rev 012821

CERTIFICATIONS:

APPLICATION:

Metering

FREQUENCY:

50-400 Hz.

INSULATION LEVEL:

600 Volts. 10 kV BIL. full wave

WINDOW DIAMETER:

4.25"

APPROXIMATE WEIGHT:

1.5 lbs.

CONNECTIONS:

- Flexible Leads are UL 1015 105°C, CSA approved #15AWG, 24" long
- Non-standard length to be specified
- SHT Terminals are brass studs No. 8-32 UNC with one flat washer, lockwasher, and regular nut



19SHT



19RL



Model	19SHT	19RL
Window Size	4.25	4.25
Width	5.92	5.92
Height	6.17	5.92
Depth	1.15	1.14

MODEL 19SHT and 19RL
Window Diameter 4.25"
Approximate weight: 3 lbs.

CATALOG NUMBER	CURRENT RATIO	V.A. FOR ± 1% CLASS	ANSI METERING CLASS AT 60 HZ					SECONDARY WINDING RESISTANCE (OHMS @ 75° C)	CONTINUOUS THERMAL RATING FACTOR	
			B0.1	B0.2	B0.5	B0.9	B1.8		@ 30°C	@ 55°C
19**-301	300:5	4	0.6	1.2	2.4	-	-	0.048	2	2
19**-401	400:5	10	0.3	0.6	1.2	-	-	0.064	2	2
19**-501	500:5	15	0.3	0.6	1.2	-	-	0.087	2	1.5
19**-601	600:5	15	0.3	0.3	0.6	1.2	-	0.116	2	1.5
19**-751	750:5	25	0.3	0.3	0.6	0.6	-	0.145	1.5	1.33
19**-801	800:5	30	0.3	0.3	0.6	0.6	-	0.155	1.5	1.33
19**-102	1000:5	30	0.3	0.3	0.6	0.6	-	0.242	1.33	1
19**-122	1200:5	40	0.3	0.3	0.3	0.6	-	0.291	1.33	1
19**-152	1500:5	15	0.3	0.3	0.6	1.2	-	0.200	1.5	1
19**-162	1600:5	15	0.3	0.3	0.3	0.6	-	0.213	1.5	1
19**-202	2000:5	20	0.3	0.3	0.3	0.6	-	0.266	1.33	1
19**-252	2500:5	20	0.3	0.3	0.3	0.3	-	0.333	1	0.8
19**-302	3000:5	25	0.3	0.3	0.3	0.3	-	0.399	1	0.8

Note: When ordering, prefix catalog number with model designation required., i.e. 19RL-301, or 19SHT-301 etc.



19SHT



19RL

Products are manufactured in a plant whose quality management system has been certified to be in compliance with ISO 9001:2015 by NQA



19 SHT

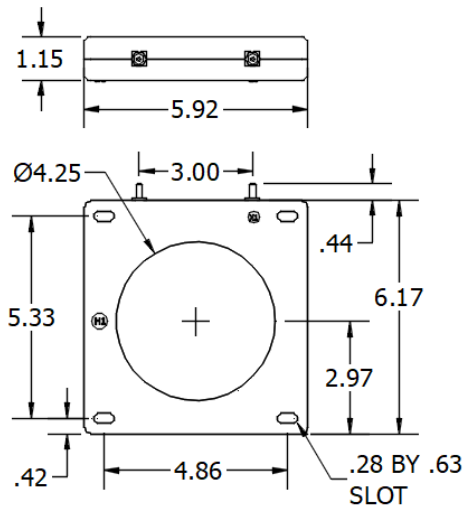

19RL

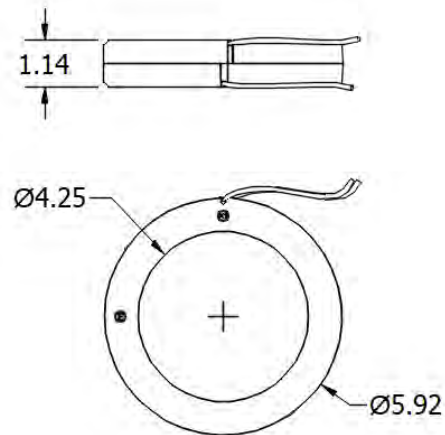

EXCITATION CURVE

