



Voltage Transformer

Model 465
rev 11152021

CERTIFICATIONS:



Model	465
Width	3.63
Height	4.25
Depth	3.75

FREQUENCY:

60 Hz.

STANDARD SECONDARY VOLTAGE:

120 Volts

INSULATION LEVEL:

600 Volts. 10 kV BIL. full wave

ACCURACY CLASS:

0.6 W. 1.2 X at 60 Hz

THERMAL RATING:

150 VA AT 30°C. amb., 100 VA AT 55°C. amb.

APPROXIMATE WEIGHT:

7.75 lbs.

CONNECTIONS:

-Terminals are brass studs No. 10-32 with one lockwasher, flat washer, and regular nut

MODEL 465
Approximate weight: 7.75 lbs.

CATALOG NUMBER NOT FUSED	VOLTAGE RATING	TURNS RATIO	REC. PRIMARY FUSE RATING
465-069	69.3:120	0.58:1	5
465-120	120:120	1:1	4
465-208	208:120	1.73:1	2
465-240	240:120	2:1	2
465-277	277:120	2.31:1	2
465-288	288:120	2.4:1	1.5
465-300	300:120	2.5:1	1.5
465-346	346:120	2.88:1	1.5
465-480*	480:120	4:1	1
465-600*	600:120	5:1	0.75

- Each transformer has two plastic terminal covers.
- The core and coil assembly is encased in a thermoplastic shell and filled with resin.
- These transformers are designed for operation line to line. They may also be operated line to ground or line to neutral at reduced voltage (58% of rated volts).
- It is desirable to use a 1.6 amp fuse in the secondary to protect the transformer.
- With two exceptions these transformers are ANSI C57.13 group 1. Those marked * are group 2.
- Models designed specifically for 50 Hz operation are available with reduced performance consult factory for details.

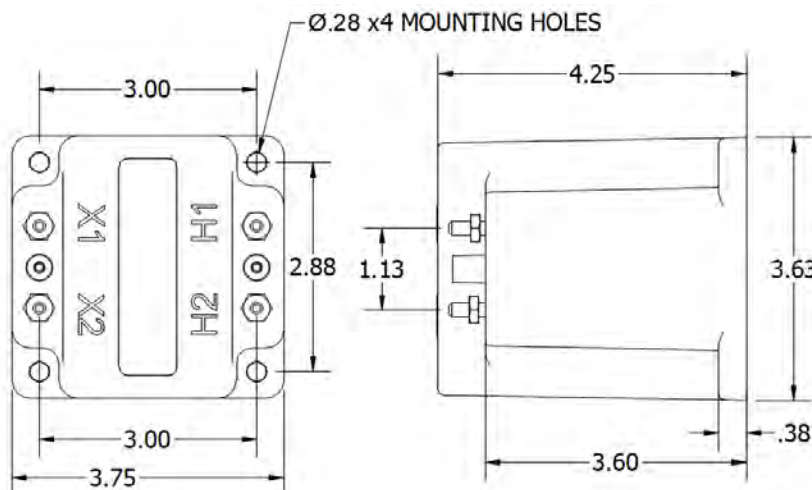

Products are manufactured in a plant whose quality management system has been certified to be in compliance with ISO 9001:2015 by NQA