



## Current Transformer

**Model 58RBL**  
rev 11152021

### CERTIFICATIONS:



#### APPLICATION:

With ammeters, wattmeters and cross current compensation

#### FREQUENCY:

50-400 Hz.

#### INSULATION LEVEL:

600 Volts. 10 kV BIL. full wave

#### WINDOW DIAMETER:

1.25"

#### APPROXIMATE WEIGHT:

1.3 lbs.

#### CONNECTIONS:

-Flexible Leads are UL 1015 105°C,

# 16AWG, 24" long

-Non-standard length to be specified

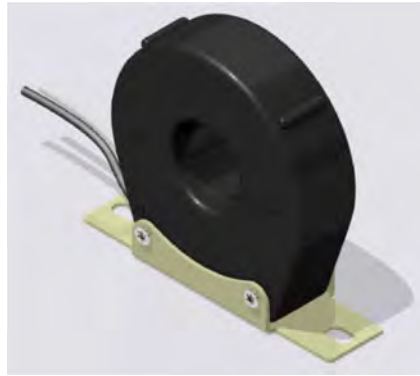

<b>Model</b>	<b>58RBL</b>
<b>Window Size</b>	1.25
<b>Width</b>	4.50
<b>Height</b>	3.70
<b>Depth</b>	1.25

### MODEL 58RBL

Window Diameter 1.25"

Approximate weight: 1.3 lbs.

CATALOG NUMBER	CURRENT RATIO	ACCURACY AT 60 HZ	BURDEN VA AT 60 HZ
58RBL-500	50:5	± 3%	1.5
58RBL-600	60:5	± 2%	2.5
58RBL-750	75:5	± 1.5%	2.5
58RBL-800	80:5	± 1%	2.5
58RBL-101	100:5	± 1.5%	5
58RBL-121	120:5	± 1%	5
58RBL-1250	125:5	± 1%	6
58RBL-151	150:5	± 1%	7.5
58RBL-201	200:5	± 1%	12.5
58RBL-251	250:5	± 1%	12.5
58RBL-301	300:5	± 1%	15
58RBL-401	400:5	± 1%	25
58RBL-501	500:5	± 1%	25
58RBL-601	600:5	± 1%	25
58RBL-751	750:5	± 1%	25
58RBL-801	800:5	± 1%	25

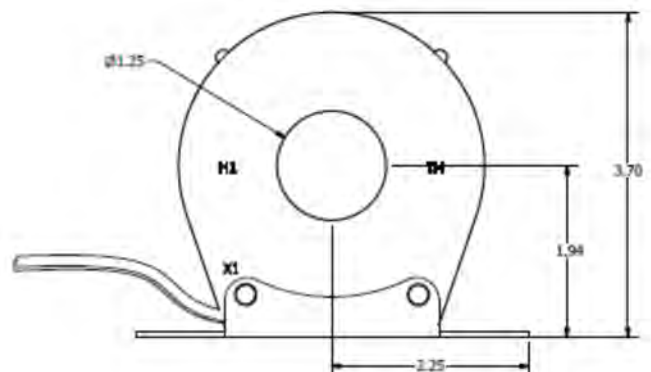
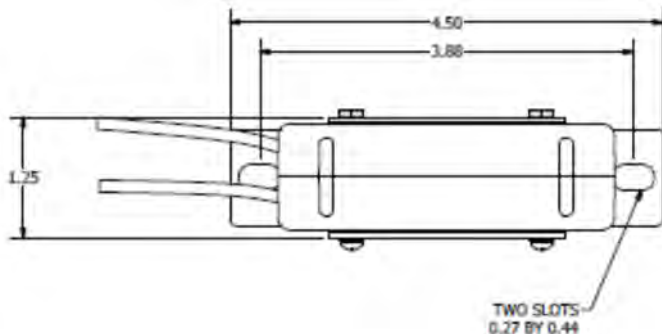

Products are manufactured in a plant whose quality management system has been certified to be in compliance with ISO 9001:2015 by NQA