

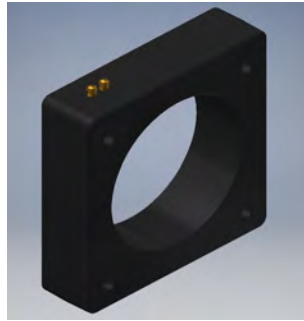

**Current Transformer
Technologies LTD**



Current Transformer



Model 144

rev 03262026

CERTIFICATIONS:



APPLICATION:

Relaying and metering.

FREQUENCY:

50-400 Hz.

INSULATION LEVEL:

600 Volts. 10 kV BIL. full wave

WINDOW DIAMETER:

6.00"

APPROXIMATE WEIGHT:

40 lbs.

CONNECTIONS:

- Terminals are brass screws No. 10-32 UNF with one flat washer and a split lock washer
- Multi-ratios available upon request
- Mounting Kit # 110-KIT (optional)

CONTINUOUS THERMAL RATING FACTOR:

The normal temperature range is -40°C to 30°C.

See chart below for the thermal factor for operation at 55°C

Model	144
Window Size	6.00
Width	11.10
Height	11.47
Depth	3.00

MODEL 144
Window Diameter 6.00"
Approximate weight: 40 lbs.

CATALOG NUMBER	CURRENT RATIO	RELAY CLASS	ANSI METERING CLASS AT 60 HZ					SECONDARY WINDING RESISTANCE (OHMS @ 75°C)	CONTINUOUS THERMAL RATING FACTOR	
			B0.1	B0.2	B0.5	B0.9	B1.8		@ 30°C	@ 55°C
144 – 500	50:5	-	2.4	4.8	-	-	-	0.020	2	2
144 – 750	75:5	C10	1.2	2.4	-	-	-	0.032	2	2
144 – 101	100:5	C10	1.2	1.2	2.4	4.8	-	0.040	2	2
144 – 151	150:5	C20	0.6	0.6	1.2	2.4	4.8	0.057	2	2
144 – 201	200:5	C20	0.6	0.6	1.2	2.4	2.4	0.067	2	2
144 – 251	250:5	C50	0.3	0.3	0.6	1.2	2.4	0.125	2	2
144 – 301	300:5	C50	0.3	0.3	0.6	0.6	1.2	0.150	2	2
144 – 401	400:5	C50	0.3	0.3	0.3	0.6	0.6	0.195	2	2
144 – 501	500:5	C100	0.3	0.3	0.3	0.6	0.6	0.282	2	2
144 – 601	600:5	C100	0.3	0.3	0.3	0.3	0.6	0.338	2	1.5
144 – 751	750:5	C100	0.3	0.3	0.3	0.3	0.3	0.213	2	2
144 – 801	800:5	C100	0.3	0.3	0.3	0.3	0.3	0.451	2	1.5
144 – 102	1000:5	C200	0.3	0.3	0.3	0.3	0.3	0.563	2	1.5
144 – 122	1200:5	C200	0.3	0.3	0.3	0.3	0.3	0.676	1.5	1.33
144 – 152	1500:5	C200	0.3	0.3	0.3	0.3	0.3	0.845	1.5	1
144 – 162	1600:5	C200	0.3	0.3	0.3	0.3	0.3	0.902	1.5	1
144 – 202	2000:5	C200	0.3	0.3	0.3	0.3	0.3	1.002	1.5	1
144 – 252	2500:5	C400	0.3	0.3	0.3	0.3	0.3	1.252	1.33	1
144 – 302	3000:5	C400	0.3	0.3	0.3	0.3	0.3	1.503	1	0.8
144 – 322	3200:5	C400	0.3	0.3	0.3	0.3	0.3	1.603	1	0.8
144 – 352	3500:5	C200	0.3	0.3	0.3	0.3	0.3	1.592	1	0.8
144 – 402	4000:5	C400	0.3	0.3	0.3	0.3	0.3	1.820	1	0.8
144 – 502	5000:5	C400	0.3	0.3	0.3	0.3	0.3	2.275	1	0.6
144 – 602	6000:5	C400	0.3	0.3	0.3	0.3	0.3	2.730	0.8	0.6

OPTIONAL MOUNTING KIT #140-KIT

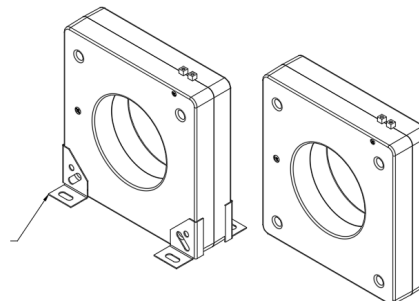

Products are manufactured in a plant whose quality management system has been certified to be in compliance with ISO 9001:2015 by NQA



Current Transformer
Technologies LTD



Current Transformer

Model 144

rev 03262026

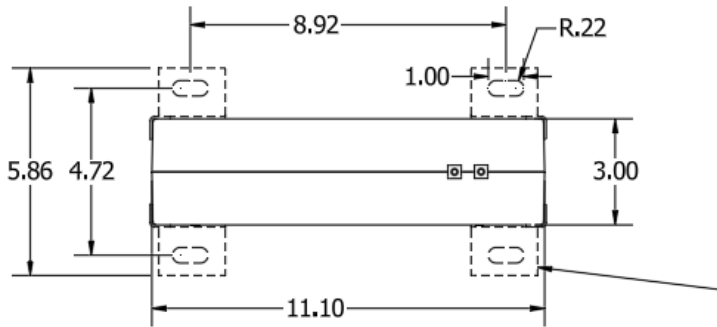

OPTIONAL MOUNTING KIT
#140-KIT

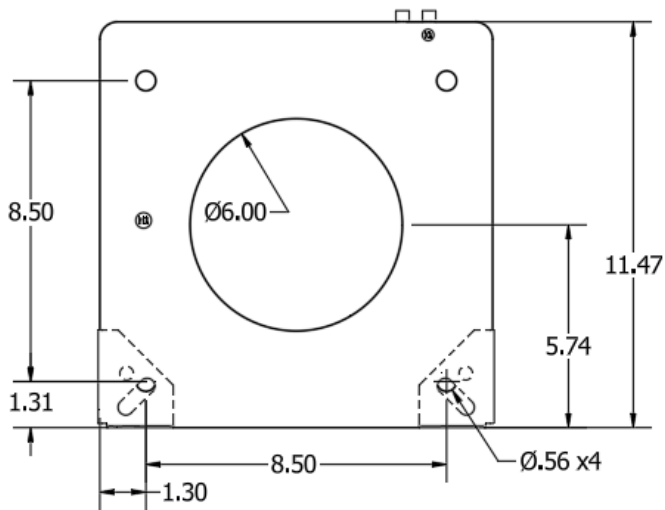

EXCITATION CURVE

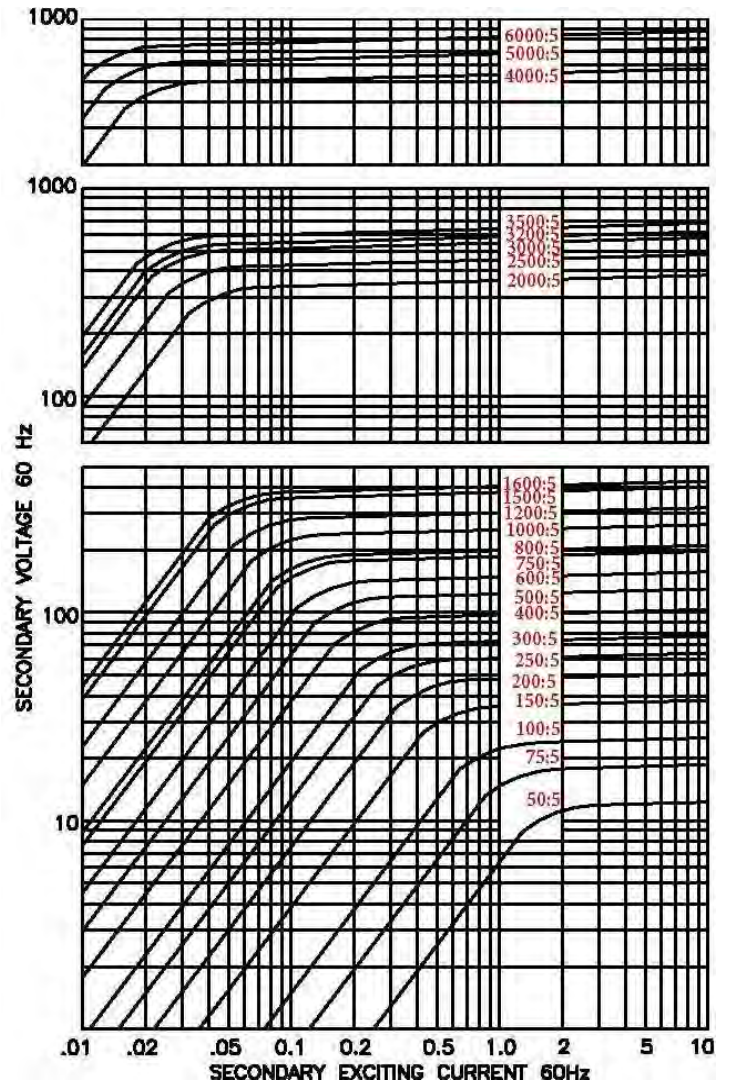

Products are manufactured in a plant whose quality management system has been certified to be in compliance with ISO 9001:2015 by NQA