



**Current Transformer
Technologies LTD**



Indoor Voltage Transformer

**Models PTG3-1-60
PTG3-2-60** Rev 11112025

CERTIFICATIONS:



ACCURACY CLASS:

0.3 WXY, 1.2Z at 100% rated voltage with 120V based ANSI burden; 0.3 WX, 0.6 M, 1.2 Y at 58% rated voltage with 69.3V based ANSI burden

FREQUENCY:

60 Hz.

MAXIMUM SYSTEM VOLTAGE:

5.6kV, BIL 60kV full wave

THERMAL RATING:

750 VA at 30°C. amb.

500 VA at 55°C. amb.

APPROXIMATE WEIGHT:

34 lbs.. unfused

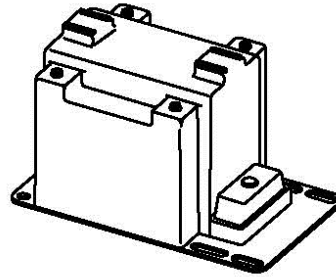

- Primary terminals that are unfused are ¼ - 20 brass screws with one flat washer and lockwasher.
- Primary terminals that are fused are ¼ - 20 brass screws with one flat washer, lockwasher, and two nuts.
- Secondary terminals are No. 10-32 brass screws with one flat washer and lockwasher.
- The core and coil assembly is encased in a plastic enclosure and vacuum encapsulated in polyurethane resin.
- Thermal burden rating is for 120 volt secondaries
- Plated steel mounting base.
- Fuses have 1" Dia Caps and 5" clip centers.
- Switchgear style is similar to fused style. No fuse or fuse clip is provided, but inserts for fuse clips are supplied.

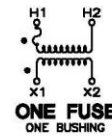
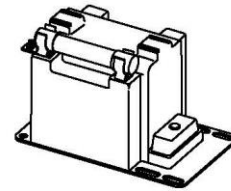
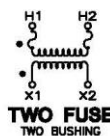
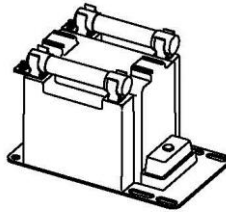
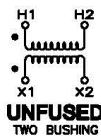
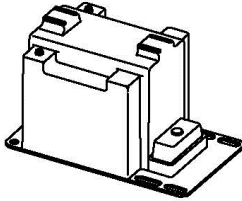

| GROUP | ONE BUSHING (b) | | | RFR FR (c) | CATALOG NUMBERS | | |
|-------|-----------------|------|-----|------------|-----------------|---------------------|------------------|
| | | | | | FUSES | FUSE CLIPS ONLY (d) | SWITCHGEAR STYLE |
| 4A | 2400 | 20:1 | 120 | 230 | PTG3-1-60-242F | PTG3-1-60-242CSorCL | PTG3-1-60-242S |
| 4B | 4200 | 35:1 | 120 | 230 | PTG3-1-60-422F | PTG3-1-60-422CSorCL | PTG3-1-60-422S |
| 4B | 4800 | 40:1 | 120 | 230 | PTG3-1-60-482F | PTG3-1-60-482CSorCL | PTG3-1-60-482S |

| GROUP | TWO BUSHING (a) | | | | CATALOG NUMBERS | | |
|-------|-----------------|-------|-------------------|---------------|-----------------|----------------------|------------------|
| | PRIMARY VOLTAGE | RATIO | SECONDARY VOLTAGE | UNFUSED | FUSES | FUSE CLIPS ONLY (d) | SWITCHGEAR STYLE |
| 1 | 2400 | 20:1 | 120 | PTG3-2-60-242 | PTG3-2-60-242FF | PTG3-2-60-242CCSorCL | PTG3-2-60-242SS |
| 2 | 3300 | 30:1 | 110-50Hz | PTG3-2-60-332 | PTG3-2-60-332FF | PTG3-2-60-332CCSorCL | PTG3-2-60-332SS |
| 2 | 4200 | 35:1 | 120 | PTG3-2-60-422 | PTG3-2-60-422FF | PTG3-2-60-422CCSorCL | PTG3-2-60-422SS |
| 2 | 4800 | 40:1 | 120 | PTG3-2-60-482 | PTG3-2-60-482FF | PTG3-2-60-482CCSorCL | PTG3-2-60-482SS |

(a) Two fuse transformers should not be used for Y connections. It is preferred practice to connect one lead from each voltage transformer directly to the neutral terminal using a fuse in the line side of the primary only. By using this connection, a transformer can never be made "live" from the line side by reason of a blown fuse in the neutral side. For continuous operation, the transformer primary voltage should not exceed 110% of rated value.

(b) Voltage transformers connected line-to-ground cannot be considered to be grounding transformers and must not be operated with the secondaries in closed delta because excessive currents may flow in the delta.

(c) Fuse clips noted as "CCS" or "CS" accept fuses with 1" Dia. Caps and 5" clip centers. Fuse clips noted as "CCL" or "CL" accept fuses with 1.63" Dia. Caps and 5.88" clip centers

NOTE: It is recommended the system line-to-line voltage not exceed the transformer maximum system voltage level.

Products are manufactured in a plant whose quality management system has been certified to be in compliance with ISO 9001:2015 by NQA



PTG3-1-60

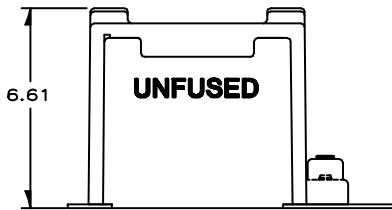
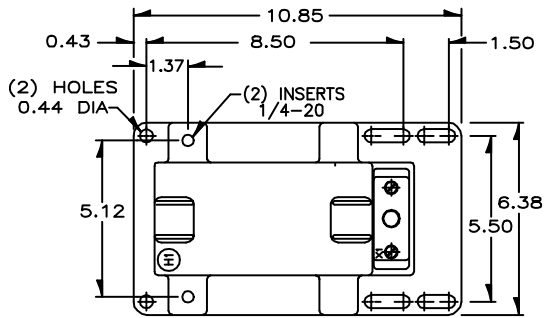

UNFUSED

PTG3-2-60

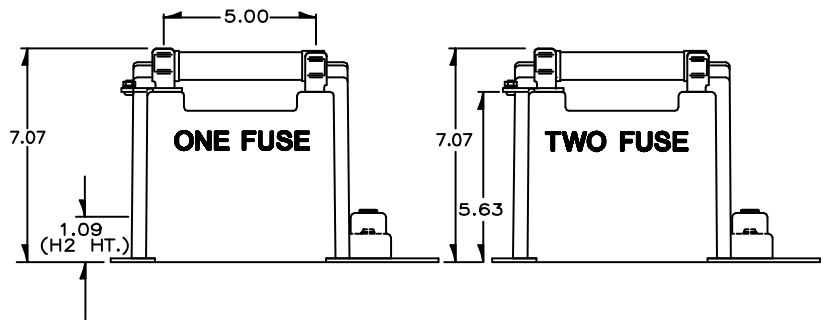
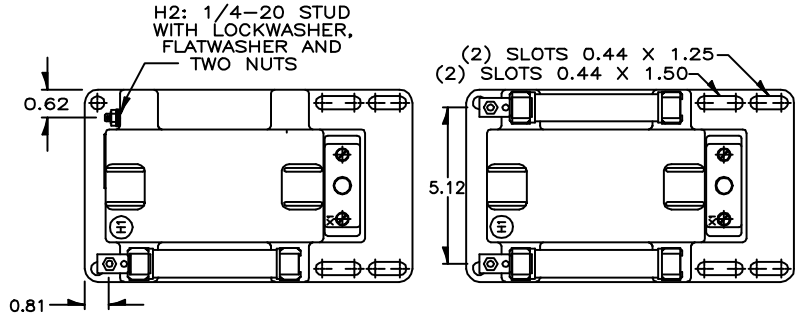

ONE FUSE

TWO FUSE

Recommended spacing is for guidance only. User needs to set appropriate values to assure performance for: high potential test; impulse test; high humidity; partial discharge, high altitude; and other considerations like configuration.

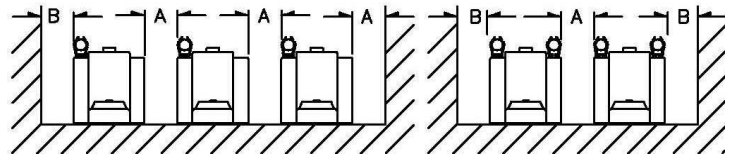

| FUSE FOR MODEL PTG3 TRANSFORMER | RATING VOLTS | INTERRUPTING AMPERES (SYM) | SUGGESTED RATING * CONTINUOUS AMPERES | CAP DIA. INCHES | LENGTH INCHES | CLIP CENTERS INCHES |
|---------------------------------|--------------|----------------------------|---------------------------------------|-----------------|---------------|---------------------|
| 2400:120V | 5.5kV | 45,000 | 2.0E | 1.0 | 5.63 | 5.00 |
| 3300:110V | 5.5kV | 45,000 | 2.0E | 1.0 | 5.63 | 5.00 |
| 4200:120V | 5.5kV | 45,000 | 1.0E | 1.0 | 5.63 | 5.00 |
| 4800:120V | 5.5kV | 45,000 | 1.0E | 1.0 | 5.63 | 5.00 |

CIRCLE DIAGRAM

The circle diagram can be used to predict the performance of a transformer for various loads and power factors. A convenient scale of volt-amperes is shown on the unity power factor line (u.p.f.) and commences at the zero or no-load locus. To use the diagram, measure the known V.A. and scribe an arc about the "zero" locus of a length that contains the angle of the burden power factor. The point at which the arc terminates is the error locus in phase angle minutes and ratio correction factor.

